

Mail Client

General

This Software is a Mail Client Module for embedded system. Mail Client Module provides E-Mail interface which has two kind of protocol such as SMTP and POP3 in order to realize the E-Mail application. Multipurpose Internet Mail Extensions (MIME) is also included.

Features

- BASE64 encode/decode can be used.
- Transmission and reception of an attached file are possible.
- There is a support function of message creation.
- Selection reception of a message is possible.

Specifications

- Protocol : SMTP, POP3, MIME
- Standard : Complies with RFC
RFC2821, RFC1939

Operating condition

- Target MCU : TLCS-900 family
- OS : TOSHIBA TR900(μITRON3.0)
- Resource Requirements : ROM 23KByte / RAM 8KByte (Minimum)

Offer contents

- Object or source code and, software document are offered.
- Demo board is available.*

Applications

- PDAs, Home Appliance, Communication Devices
- Remote Control Device
- notify of a system error condition

Recommended MCU

- TMP92C820F 32bit CISC MCU (ROM Less, Internal RAM8K, 61 I/O Ports)
- TMP92CM22F 32bit CISC MCU (ROM Less, Internal RAM32K, 49 I/O Ports)

*For details, please contact your local Toshiba office.

TOSHIBA Semiconductor Company Website: <http://www.semicon.toshiba.co.jp/eng/index.html>

Software structure

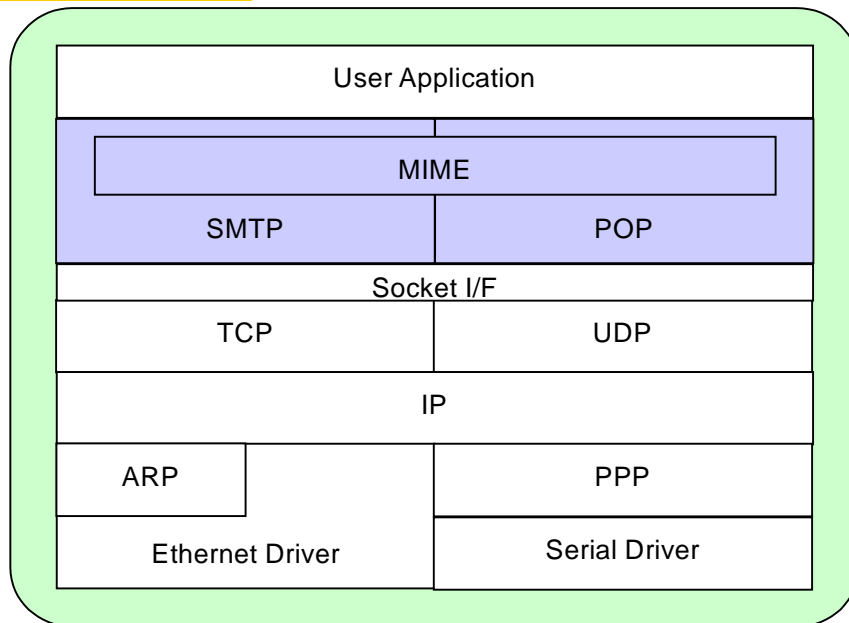

System Diagram

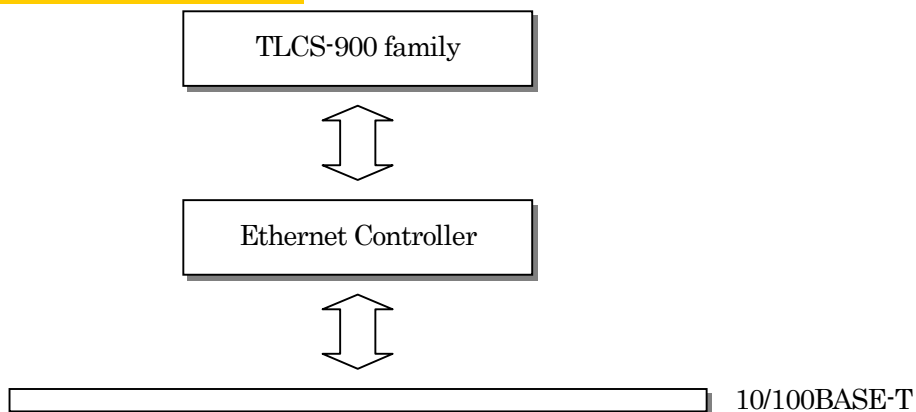

- The information contained herein is subject to change without notice.
- The information contained herein is presented only as a guide for the applications of our products. No responsibility is assumed by TOSHIBA CORPORATION for any infringements of intellectual property or other rights of the third parties which may result from its use. No license is granted by implication or otherwise under any intellectual property or other rights of TOSHIBA CORPORATION or others.
- TOSHIBA is continually working to improve the quality and reliability of its products. Nevertheless, semiconductor devices in general can malfunction or fail due to their inherent electrical sensitivity and vulnerability to physical stress. It is the responsibility of the buyer, when utilizing TOSHIBA products, to comply with the standards of safety in making a safe design for the entire system, and to avoid situations in which a malfunction or failure of such TOSHIBA products could cause loss of human life, bodily injury or damage to property. In developing your designs, please ensure that TOSHIBA products are used within specified operating ranges as set forth in the most recent TOSHIBA products specifications. Also, please keep in mind the precautions and conditions set forth in the "Handling Guide for Semiconductor Devices," or "TOSHIBA Semiconductor Reliability Handbook" etc..
- The TOSHIBA products listed in this document are intended for usage in general electronics applications (computer, personal equipment, office equipment, measuring equipment, industrial robotics, domestic appliances, etc.). These TOSHIBA products are neither intended nor warranted for usage in equipment that requires extraordinarily high quality and/or reliability or a malfunction or failure of which may cause loss of human life or bodily injury ("Unintended Usage"). Unintended Usage include atomic energy control instruments, airplane or spaceship instruments, transportation instruments, traffic signal instruments, combustion control instruments, medical instruments, all types of safety devices, etc.. Unintended Usage of TOSHIBA products listed in this document shall be made at the customer's own risk.
- TOSHIBA is continually working to improve the quality and reliability of its products. Nevertheless, the hardware and software incorporated in this TOSHIBA products in general can malfunction or fail due to their inherent electrical sensitivity and vulnerability to physical stress.
- TOSHIBA does not take any responsibility for incidental damage "including loss of business profit, business interruption, loss of business information, and other pecuniary damage" arising out of the use or disability to use the product.
- The products described in this document are subject to the foreign exchange and foreign trade laws.
- TOSHIBA products should not be embedded to the downstream products which are prohibited to be produced and sold, under any law and regulations.

TOSHIBA

Revision 1.2 June/2003