

TENTATIVE

FM200TU-07A

Pre.	M.Koura	Rev	B	M.Koura, N.Kashimoto, J.Yamada T. Furuike 28. Apr. '04
Apr.	T.Furuike 03-Mar.-'04			

HIGH POWER SWITCHING USE

Notice : This is not a final specification. Some parametric limits are subject to change.

FM200TU-07A

- $I_{D(rms)}$ 100A
- V_{DSS} 75V
- Insulated Type
- 6-elements in a pack

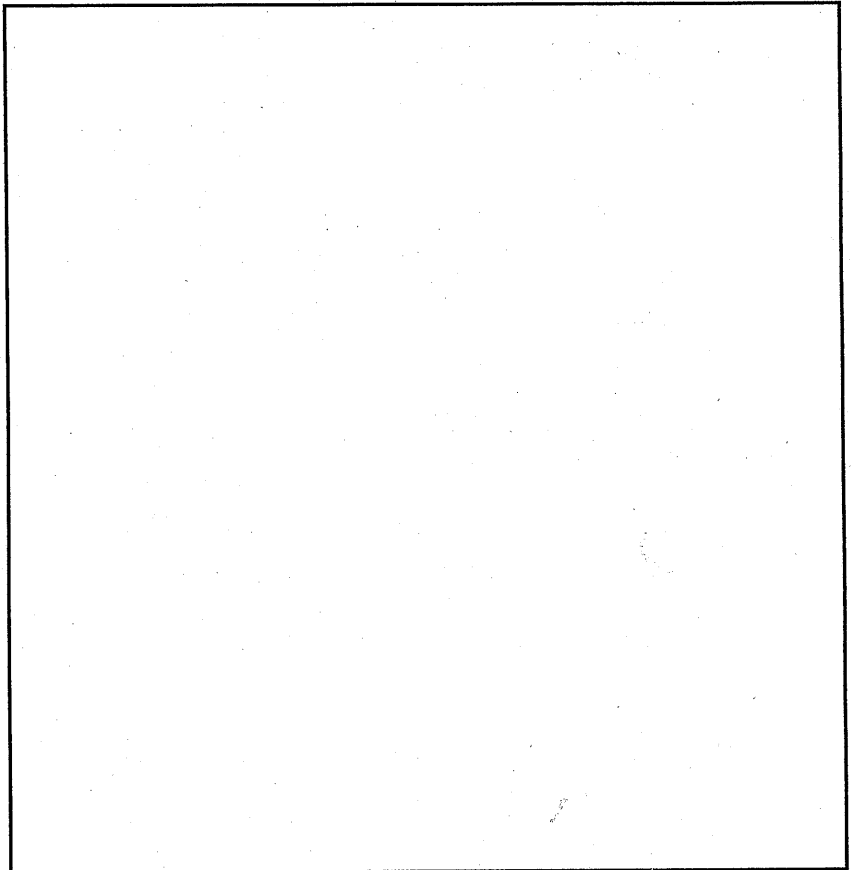

A
B

APPLICATION

AC motor control of forklift (battery power source)

ABSOLUTE MAXIMUM RATINGS ($T_{ch} = 25\text{ }^{\circ}\text{C}$)

Symbol	Item	Conditions	Ratings	Unit
V_{DSS}	Drain-source voltage	G-S Short	75	V
V_{GSS}	Gate-source voltage	D-S Short	± 20	V
$I_{D(rms)}$	Drain current	$T_c = 142\text{ }^{\circ}\text{C}$	100	$A_{(rms)}$
I_{DM}		Pulse ②	200	A
I_{DA}	Avalanche current	$L = 10\text{ }\mu\text{H}$ Pulse ②	100	A
$I_{S(rms)}$ ①	Source current		100	$A_{(rms)}$
I_{SM} ①		Pulse ②	200	A
P_D ③	Maximum power dissipation	$T_c = 25\text{ }^{\circ}\text{C}$	410	W
P_D ③	Maximum power dissipation	$T_c' = 25\text{ }^{\circ}\text{C}$	560^{*1}	W
T_{ch}	Channel temperature		$-40 \sim +150$	$^{\circ}\text{C}$
T_{stg}	Storage temperature		$-40 \sim +125$	$^{\circ}\text{C}$
V_{iso}	Isolation voltage	Main terminal to base plate, AC 1 min.	2500	V
—	Mounting torque	Main Terminal M 6	3.5~4.5	N·m
		Mounting M 6	3.5~4.5	N·m
—	Weight	Typical value	600	g

B
B
B

TENTATIVE**FM200TU-07A**

HIGH POWER SWITCHING USE

ELECTRICAL CHARACTERISTICS ($T_{ch} = 25\text{ }^{\circ}\text{C}$)

Symbol	Item	Conditions	Min.	Typ.	Max.	Unit	
I_{DSS}	Drain cutoff current	$V_{DS}=V_{DSS}, V_{GS}=0V$	—	—	1	mA	
$V_{GS(th)}$	Gate-source threshold voltage	$I_D=10mA, V_{DS}=10V$	4.7	6	7.3	V	
I_{GSS}	Gate leakage current	$V_{GS}=V_{GSS}, V_{DS}=0V$	—	—	1.5	μA	
$r_{DS(ON)}$ (chip)	Static drain-source On-state resistance	$I_D=100A$ $V_{GS}=15V$	$T_{ch}=25\text{ }^{\circ}\text{C}$	—	1.2	1.65	m Ω
			$T_{ch}=125\text{ }^{\circ}\text{C}$	—	1.92	—	
$V_{DS(ON)}$ (chip)	Static drain-source On-state voltage	$I_D=100A$ $V_{GS}=15V$	$T_{ch}=25\text{ }^{\circ}\text{C}$	—	0.12	0.165	V
			$T_{ch}=125\text{ }^{\circ}\text{C}$	—	0.192	—	
$R_{(lead)}$	Lead resistance	$I_D=100A$ terminal-chip	$T_{ch}=25\text{ }^{\circ}\text{C}$	—	1.2	—	m Ω
			$T_{ch}=125\text{ }^{\circ}\text{C}$	—	1.68	—	
C_{iss}	Input capacitance	$V_{DS}=10V$ $V_{GS}=0V$	—	—	50	nF	
C_{oss}	Output capacitance		—	—	7		
C_{rss}	Reverse transfer capacitance		—	—	4		
Q_G	Total gate charge	$V_{DD}=48V, I_D=100A, V_{GS}=15V$	—	700	—	nC	
$t_{d(on)}$	Turn-on delay time	$V_{DD}=48V, I_D=100A$ $V_{GS1}=V_{GS2}=15V$ $R_G=13\Omega$, Inductive load switching operation	—	—	450	ns	
t_r	Turn-on rise time		—	—	400		
$t_{d(off)}$	Turn-off delay time		—	—	600		
t_f	Turn-off fall time		—	—	400		
t_{rr} ①	Reverse recovery time		$I_S=100A$	—	—		200
Q_{rr} ①	Reverse recovery charge		—	2.0	—	μC	
V_{SD} ①	Source-drain voltage	$I_S=100A, V_{GS}=0V$	—	—	1.3	V	
$R_{th(ch-c)}$	Thermal resistance	MOSFET part(1/6 module)	—	—	0.30	$^{\circ}\text{C/W}$	
$R_{th(ch-c)}$		MOSFET part(1/6 module)	—	—	0.22*1		
$R_{th(c-f)}$		Contact thermal resistance	Case to fin, Thermal compound Applied *2 (1/6 module)	—	0.1		—

Thermistors part

Symbol	Parameter	Condition	Min.	Typ.	Max.	Unit
R_{TH} ④	Resistance	$T_C=25^{\circ}\text{C}$	—	100	—	k Ω
B ④	B Constant	Resistance at $25^{\circ}\text{C}, 50^{\circ}\text{C}$	—	4000	—	K

① I_S, V_{SD}, t_{rr} & Q_{rr} represent characteristics of the anti-parallel, source to drain free-wheel diode (FWD).② Pulse width and repetition rate should be such that the device channel temp. (T_{ch}) dose not exceed T_{ch} max rating.③ Channel temperature (T_{ch}) should not increase beyond 150°C .④ $B = (\ln R_1 - \ln R_2) / (1/T_1 - 1/T_2)$ R_1 : Resistance at $T_1(K)$, R_2 : Resistance at $T_2(K)$ *1: T_c measured point is just under the chips. If you use this value, $R_{th}(f-a)$ should be measured just under the chips.

*2: Typical value is measured by using Shin-etsu Silicone "G-746".

*3: T_c measured point is shown in page "3-4".

TENTATIVE

FM200TU-07A

HIGH POWER SWITCHING USE

OUTLINE DRAWING

Dimensions in mm

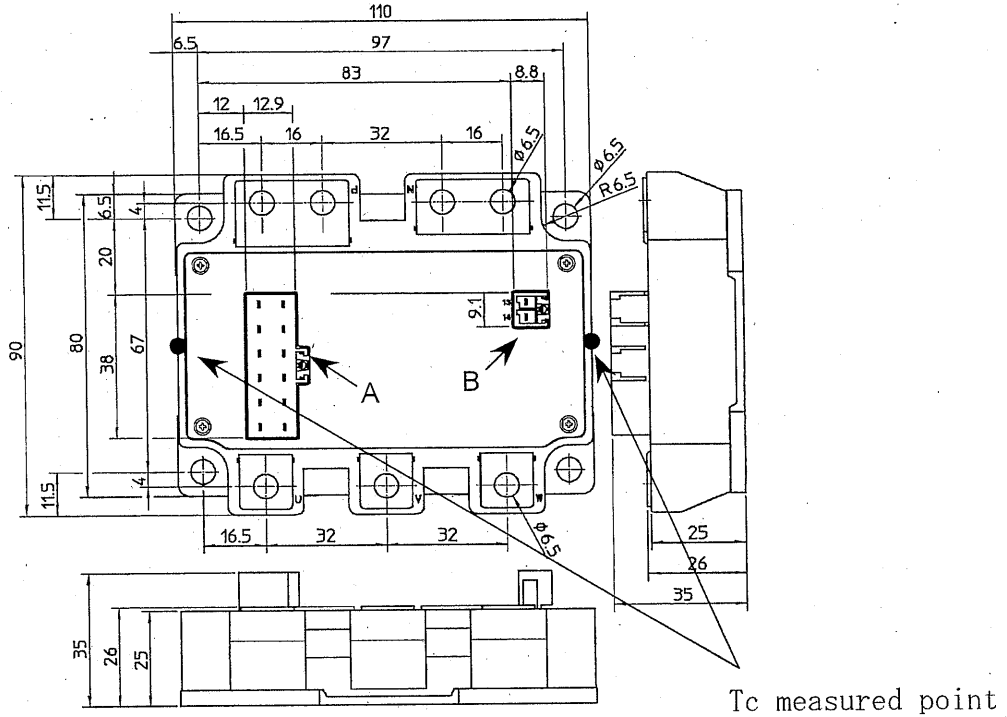

Housing Type of A and B
(Tyco Electronics P/N:)
A: 917353-1
B: 179838-1

CIRCUIT DIAGRAM

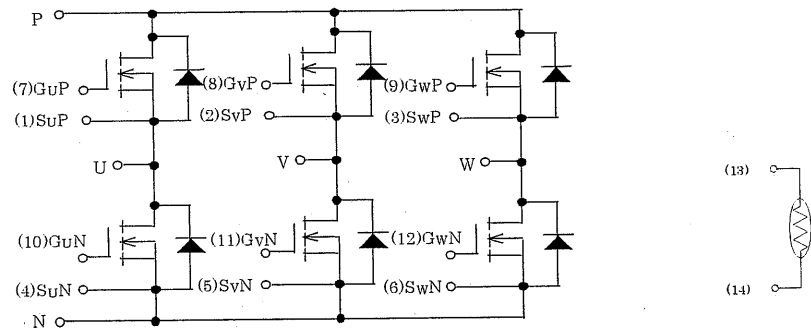

(1) SUP	(2) SVP	(3) SWP	(4) SUN	(5) SVN	(6) SWN	A
(7) GUP	(8) GVP	(9) GWP	(10) GUN	(11) GVN	(12) GWN	B
(13) TH1	(14) TH2					

Keep safety first in your circuit designs!

- Mitsubishi Electric Corporation puts the maximum effort into making semiconductor products better and more reliable, but there is always the possibility that trouble may occur with them. Trouble with semiconductors may lead to personal injury, fire or property damage. Remember to give due consideration to safety when making your circuit designs, with appropriate measures such as (i) placement of substitutive, auxiliary circuits, (ii) use of non-flammable material or (iii) prevention against any malfunction or mishap.

Notes regarding these materials

- These materials are intended as a reference to assist our customers in the selection of the Mitsubishi semiconductor product best suited to the customer's application; they do not convey any license under any intellectual property rights, or any other rights, belonging to Mitsubishi Electric Corporation or a third party.
- Mitsubishi Electric Corporation assumes no responsibility for any damage, or infringement of any third-party's rights, originating in the use of any product data, diagrams, charts, programs, algorithms, or circuit application examples contained in these materials.
- All information contained in these materials, including product data, diagrams, charts, programs and algorithms represents information on products at the time of publication of these materials, and are subject to change by Mitsubishi Electric Corporation without notice due to product improvements or other reasons. It is therefore recommended that customers contact Mitsubishi Electric Corporation or an authorized Mitsubishi Semiconductor product distributor for the latest product information before purchasing a product listed herein.
The information described here may contain technical inaccuracies or typographical errors. Mitsubishi Electric Corporation assumes no responsibility for any damage, liability, or other loss rising from these inaccuracies or errors.
Please also pay attention to information published by Mitsubishi Electric Corporation by various means, including the Mitsubishi Semiconductor home page (<http://www.mitsubishichips.com>).
- When using any or all of the information contained in these materials, including product data, diagrams, charts, programs, and algorithms, please be sure to evaluate all information as a total system before making a final decision on the applicability of the information and products. Mitsubishi Electric Corporation assumes no responsibility for any damage, liability or other loss resulting from the information contained herein.
- The prior written approval of Mitsubishi Electric Corporation is necessary to reprint or reproduce in whole or in part these materials.
- Mitsubishi Electric Corporation semiconductors are not designed or manufactured for use in a device or system that is used under circumstances in which human life is potentially at stake. Please contact Mitsubishi Electric Corporation or an authorized Mitsubishi Semiconductor product distributor when considering the use of a product contained herein for any specific purposes, such as apparatus or systems for transportation, vehicular, medical, aerospace, nuclear, or undersea repeater use.
- If these products or technologies are subject to the Japanese export control restrictions, they must be exported under a license from the Japanese government and cannot be imported into a country other than the approved destination.
Any diversion or reexport contrary to the export control laws and regulations of Japan and/or the country of destination is prohibited.
- Please contact Mitsubishi Electric Corporation or an authorized Mitsubishi Semiconductor product distributor for further details on these materials or the products contained therein.