



ISSI[®]

Advanced Memory Solutions

Product Selector Guide 2005

DRAM

SRAM

EEPROM

LOGIC

ICSI PRODUCTS

GLYN
High-Tech Distribution



Dear Valued Customer,

We recently brought ISSI and ICSI together into one new and great company. The integration of the two operations into the new ISSI, makes ISSI the largest fabless SRAM and DRAM company in the world. The new larger company gains significant economies of scale, expanded and swifter new product development, and a broader product portfolio.

We will continue to support products from both companies. And products that are currently available from both companies will continue to be available with their respective logo.

To better serve you, in most cases, we have been able to maintain the sales channels of both companies and expanded the product offering of all the representatives and distributors to include products from both companies.

We look forward to serving you as the new and stronger ISSI.

Sanjiv Asthana
Vice President of Sales and Marketing
Integrated Silicon Solution Inc.

SYNCHRONOUS SRAM

Pipelined and Flow-Thru Synchronous SRAM

Den	Org	Part No.	Vcc	VccQ	Speed (Mhz)	tKQ (ns)	Pkg (#Pins)	Status ⁽¹⁾⁽²⁾	Comment ^(3,4,5,6,7,8)
1M	32Kx32	IS61C632A	3.3V	3.3V	100,83,75	5,6,7	TQFP(100)	Prod	P
	32Kx32	IS61LV632A	3.3V	2.5V	100,83,75	5,6,7	TQFP(100)	Prod	P
2M	64Kx32	IS61LF6432A	3.3V	2.5V/3.3V	90	8,5	TQFP(100)	Prod	F
	64Kx32	IS61LP6432A	3.3V	2.5V/3.3V	133	4	TQFP(100)	Prod	P
	64Kx36	IS61LF6436A	3.3V	2.5V/3.3V	90	8,5	TQFP(100)	Prod	F
	64Kx36	IS61LP6436A	3.3V	2.5V/3.3V	166,133	3,5,4	TQFP(100),PBGA(119)	Prod	P
4M	128Kx32	IS61LF12832	3.3V	2.5V	113,100	7,5,8,5	PBGA(119), TQFP(100)	Prod	F,SC
	128Kx32	IS61LP12832	3.3V	2.5V/3.3V	200, 166	3,1,3,5	PBGA(119), TQFP(100)	Prod	P,SC
	128Kx32	IS61SF12832	3.3V	3.3V	117,100,90,66	7,5,8,8,5, 10	PBGA(119), TQFP(100)	Prod	F,SC
	128Kx32	IS61SP12832	3.3V	3.3V	166, 133 ,100	3,5,4,5	PBGA(119), TQFP(100)	Prod	P,SC
	128Kx36	IS61LF12836	3.3V	2.5V	113,100	7,5,8,5	PBGA(119), TQFP(100)	Prod	F,SC
	128Kx36	IS61LP12836	3.3V	2.5V/3.3V	200, 166	3,1,3,5	PBGA(119), TQFP(100)	Prod	P,SC
	128Kx36	IS61SF12836	3.3V	3.3V	117,100,90,66	7,5,8,8,5, 10	PBGA(119), TQFP(100)	Prod	F,SC
	128Kx36	IS61SP12836	3.3V	3.3V	166 , 133 ,100	3,5,4,5	PBGA(119),TQFP(100)	Prod	P,SC
	256Kx18	IS61SF25618	3.3V	3.3V	100,90,66	8,8,5, 10	PBGA(119), TQFP(100)	Prod	F,SC
	256Kx18	IS61SP25618	3.3V	3.3V	166,150, 133 ,100	3,5,3,8,4,5	PBGA(119), TQFP(100)	Prod	P,SC
	128Kx32	IS61LPS12832A					PBGA(119), TQFP(100)		
	128Kx36	IS61LPS12836A	3.3V	3.3V/2.5V	250	2,6	BGA(165)	S=NOW	P,SC,L
	256Kx18	IS61LPS25618A							
	128Kx36	IS61VPS12836A	2.5V	2.5V	250,200	2,6,3,1	PBGA(119), TQFP(100)	S=NOW	P,SC,L
	256Kx18	IS61VPS25618A					BGA(165)		
	128Kx36	IS61LPD12836A	3.3V	2.5V/3.3V	250	2,6	PBGA(119), TQFP(100)	S=NOW	P,DC
	256Kx18	IS61LPD25618A					BGA(165)		
	128Kx36	IS61VPD12836A	2.5V	2.5V	250	2,6	PBGA(119), TQFP(100)	S=NOW	P,DC
	256Kx18	IS61VPD25618A					BGA(165)		
	128Kx32	IS61LF12832A					PBGA(119), TQFP(100)		
128Kx36	IS61LF12836A	3.3V	2.5V/3.3V	133	6,5	BGA(165)	S=NOW	F,L	
256Kx18	IS61LF25618A								
128Kx36	IS61VF12836A	2.5V	2.5V	133	6,5	PBGA(119), TQFP(100)	S=NOW	F	
256Kx18	IS61VF25618A					BGA(165)			
8M	256Kx36	IS61LPS25636A	3.3V	3.3V/2.5V	250	2,6	PBGA(119), TQFP(100)	Prod	P,SC,L
	512Kx18	IS61LPS51218A					BGA(165)		
	256Kx36	IS61VPS25636A	2.5V	2.5V	250,200	2,6,3,1	PBGA(119), TQFP(100)	Prod	P,SC,L
	512Kx18	IS61VPS51218A					BGA(165)		
	256Kx36	IS61LPD25636A	3.3V	2.5V/3.3V	250	2,6	PBGA(119), TQFP(100)	Prod	P,DC
	512Kx18	IS61LPD51218A					BGA(165)		
	256Kx36	IS61VPD25636A	2.5V	2.5V	250	2,6	PBGA(119), TQFP(100)	Prod	P,DC
	512Kx18	IS61VPD51218A					BGA(165)		
	256Kx36	IS61LF25636A	3.3V	2.5V/3.3V	133	6,5	PBGA(119), TQFP(100)	Prod	F
	512Kx18	IS61LF51218A					BGA(165)		
256Kx36	IS61VF25636A	2.5V	2.5V	133	6,5	PBGA(119), TQFP(100)	Prod	F	
512Kx18	IS61VF51218A					BGA(165)			
18M	256Kx72	IS61LPS25672A	3.3V	3.3V/2.5V	250	2,6	BGA(209)	Prod	P,SC
	512Kx36	IS61LPS51236A	3.3V	3.3V/2.5V	250	2,6	PBGA(119), TQFP(100)	Prod	P,SC,L
	1Mx18	IS61LPS102418A					BGA(165)		
	256Kx72	IS61VPS25672A	3.3V	3.3V/2.5V	250	2,6	BGA(209)	Prod	P,SC
	512Kx36	IS61VPS51236A	2.5V	2.5V	250	2,6	PBGA(119), TQFP(100)	Prod	P,SC
	1Mx18	IS61VPS102418A					BGA(165)		

Notes: 1. S = Sample 2. Prod = Production 3. CE = Chip Enable 4. P = Pipeline
 5. F = Flow Through 6. SC = Single Cycle Deselect 7. DC = Double Cycle Deselect 8. L = Lead-free
 9. Items in **bold** are recommended samples and commonly ordered products as defined by ISSI

SYNCHRONOUS SRAM (CONT'D)

Pipelined and Flow-Thru Synchronous SRAM (Cont'd)

Den	Org	Part No.	Vcc	VccQ	Speed (Mhz)	tKQ (ns)	Pkg (#Pins)	Status ⁽¹⁾⁽²⁾	Comment ^(3,4,5,6,7)
18M	512Kx36	IS61LPD51236A	3.3V	2.5V/3.3V	250	2.6	TQFP(100)	Prod	P,DC
	1Mx18	IS61LPD102418A					BGA(165)		
	512Kx36	IS61VPD51236A	2.5V	2.5V	250	2.6	TQFP(100)	Prod	P,DC
	1Mx18	IS61VPD102418A					BGA(165)		
	256Kx72	IS61LF25672A	3.3V	2.5V/3.3V	133	6.5	PBGA(119),TQFP(100)	Prod	F, L
	512Kx36	IS61LF51236A					BGA(165),BGA(209)		
	1Mx18	IS61LF102418A	2.5V	2.5V	133	6.5	PBGA(119),TQFP(100)	Prod	F
256Kx72	IS61VF25672A	BGA(165),BGA(209)							
512Kx36	IS61VF51236A	1Mx18	IS61VF102418A						

No-Wait Synchronous SRAM (Compatible with Zero Bus Turnaround devices)

Den	Org	Part No.	Vcc	VccQ	Speed (Mhz)	tKQ (ns)	Pkg (#Pins)	Status ⁽¹⁾⁽²⁾	Comment ^(3,4,7)
4M	128Kx32	IS61NLP12832A	3.3V	2.5V/3.3V	250	2.6	PBGA(119),TQFP(100)	S=NOW	P
	128Kx36	IS61NLP12836A					BGA(165)		
	256Kx18	IS61NLP25618A	2.5V	2.5V	250	2.6	PBGA(119),TQFP(100)	S=NOW	P
	128Kx36	IS61NVP12836A					BGA(165)		
	256Kx18	IS61NVP25618A	3.3V	2.5V/3.3V	133	6.5	TQFP(100)	S=NOW	F
	128Kx36	IS61NLF12836A					PBGA(119),BGA(165)		
	256Kx18	IS61NLF25618A	2.5V	2.5V	133	6.5	TQFP(100)	S=NOW	F
128Kx36	IS61NVF12836A	PBGA(119),BGA(165)							
256Kx18	IS61NVF25618A	3.3V	2.5V/3.3V	250	2.6	PBGA(119),TQFP(100)	Prod	P	
256Kx36	IS61NLP25636A					BGA(165)			
8M	512Kx18	IS61NLP51218A	2.5V	2.5V	250	2.6	PBGA(119),TQFP(100)	Prod	P
	256Kx36	IS61NVP25636A					BGA(165)		
	512Kx18	IS61NVP51218A	3.3V	2.5V/3.3V	133	6.5	TQFP(100)	Prod	F
	256Kx36	IS61NLF25636A					PBGA(119),BGA(165)		
	512Kx18	IS61NLF51218A	2.5V	2.5V	133	6.5	TQFP(100)	Prod	F
	256Kx36	IS61NVF25636A					PBGA(119),BGA(165)		
	512Kx18	IS61NVF51218A	1.8V	1.8V	250,200	2.6,3.2	BGA(209)	S=NOW	P
256Kx72	IS61NVVP25672	PBGA(119)							
18M	512Kx36	IS61NVVP51236	3.3V	2.5V/3.3V	250	2.6	BGA(209),TQFP(100)	Prod	P, L
	256Kx72	IS61NLP25672					BGA(165)		
	512Kx36	IS61NLP51236	2.5V	2.5V	250	2.6	BGA(209),TQFP(100)	Prod	P
	1Mx18	IS61NLP102418					BGA(165)		
	256Kx72	IS61NVP25672	3.3V	2.5V/3.3V	133	6.5	BGA(209),TQFP(100)	Prod	F
	512Kx36	IS61NVP51236					BGA(165)		
	1Mx18	IS61NVP102418	2.5V	2.5V	133	6.5	BGA(209),TQFP(100)	Prod	F
	256Kx72	IS61NLF25672					BGA(165)		
	512Kx36	IS61NLF51236	1Mx18	IS61NLF102418					
	256Kx72	IS61NVF25672							
	512Kx36	IS61NVF51236	BGA(165)						
	1Mx18	IS61NVF102418	512Kx72	IS61NLP51272	2.5V/3.3V	250	2.6	BGA(165),BGA(209)	S=NOW
	36M	1Mx36						IS61NLP102436	

Notes:

1. S = Sample 2. Prod = Production 3. P = Pipeline 4. F = Flow Through 5. SC = Single Cycle Deselect
6. DC = Double Cycle Deselect 7. L = Lead-free
8. Items in **bold** are recommended samples and commonly ordered products as defined by ISSI

SYNCHRONOUS SRAM (CONT'D)

Ultra Data Rate (UDR) Synchronous SRAM

Family	Den	Org	Part No.	Burst Length	Speed (Mhz)	Status ⁽¹⁾⁽²⁾
QUAD	36Mb	1Mx36	IS61QDB41M36	4	250	Prod
	36Mb	2Mx18	IS61QDB42M18	4	250	Prod
	36Mb	1Mx36	IS61QDB21M36	2	250	Prod
	36Mb	2Mx18	IS61QDB22M18	2	250	Prod
DDR-II	36Mb	1Mx36	IS61DDB41M36	4	250	Prod
	36Mb	2Mx18	IS61DDB42M18	4	250	Prod
	36Mb	1Mx36	IS61DDB21M36	2	250	Prod
	36Mb	2Mx18	IS61DDB22M18	2	250	Prod

ASYNCHRONOUS SRAM

High-Speed Asynchronous SRAM

Den	Org	Part No.	Vcc	Speeds (ns)	Pkg (#Pins)	Status ⁽¹⁾⁽²⁾	Comment ^(3,4)
64K	8Kx8	IS61C64B	4.5V-5.5V	10,12,15	SOJ(28),TSOP1(28)	Prod	CE Active Low
256K	32Kx8	IS61C256AH	4.5V-5.5V	10,12,15	SOJ(28),TSOP1(28)	Prod	
512K	32Kx16	IS61C3216	4.5V-5.5V	12,15	SOJ(44),TSOP2(44)	Prod	CE Active Low
1M	64Kx16	IS61C6416AL	4.5V-5.5V	12	SOJ(44),TSOP2(44)	Prod	L
	128Kx8	IS61C1024AL	5.0V	12	SOJ(32.3),SOJ(32.4) TSOP1(32),sTSOP1(32)	Prod	L

Low Power Asynchronous SRAM

Den	Org	Part No.	Vcc	Speeds (ns)	Pkg (#Pins)	Status ⁽¹⁾⁽²⁾	Comment ⁽⁴⁾
256K	32Kx8	IS62C256	4.5V-5.5V	45,70	SOP(28),TSOP1(28)	Prod	
1M	128Kx8	IS62C1024AL	5.0V	35	SOP(32),TSOP1(32)	Prod	L

High Speed Low Power Asynchronous SRAM

Den	Org	Part No.	Vcc	Speed (ns)	Pkg (#Pins)	Status ⁽¹⁾⁽²⁾	Comment ⁽⁴⁾
256K	32Kx8	IS61LV256	3.3V	8,10,12,15	SOJ(28),TSOP1(28)	Prod	L
512K	32Kx16	IS61LV3216L	3.3V	10,12,15	SOJ(44),TSOP2(44)	Prod	
1M	64Kx16	IS61LV6416/L	3.3V	8,10,12	SOJ(44),TSOP2(44),mBGA(48)	Prod	L
	64Kx16	IS61WV6416LL	2.5V-3.6V	20	TSOP2(44),mBGA(48)	Prod	L, Typ. Isb is 4uA
	128Kx8	IS63LV1024/L	3.3V	8,10,12	SOJ(32.3),SOJ(32.4),TSOP2(32), mBGA(36),sTSOP1(32)	Prod	L, Center Vcc & GND
	128Kx8	IS63WV1024LL	2.5V-3.6V	20	TSOP2(32),mBGA(36) sTSOP1(32),SOJ(32.3)	Prod	L Typ. Isb is 4uA
2M	128Kx16	IS61LV12816L	3.3V	8,10	LQFP(44),TSOP2(44),mBGA(48)	Prod	L
	128Kx16	IS61WV12816BLL	2.5V-3.6V	12,15	TSOP2(44),mBGA(48)	Prod	
	256Kx8	IS61LV2568L	3.3V	8,10	SOJ(36),TSOP2(44)	Prod	
3M	128Kx24	IS61LV12824	3.3V	8,9,10	PBGA(119),TQFP(100)	Prod	L, x24 Interface
4M	256Kx16	IS61LV25616AL	3.3V	10,12	LQFP(44),SOJ(44),TSOP2(44), mBGA(48)	Prod	L
	512Kx8	IS61LV5128AL	3.3V	10,12	SOJ(36),TSOP2(44),mBGA(36)	Prod	L
	512Kx16	IS61LV51216	3.3V	8,10,12	TSOP2(44),mBGA(48)	Prod	L
8M	1Mx8	IS61LV10248	3.3V	8,10	TSOP2(44),mBGA(48),mBGA(36)	Prod	

Notes:

1. S = Sample 2. Prod = Production 3. 2CS = 2 chip enable 4. L = Lead-free
5. Items in **bold** are recommended samples and commonly ordered products as defined by ISSI

ASYNCHRONOUS SRAM (CONT'D)

PowerSaver™ Low Power Asynchronous SRAM

Den	Org	Part No.	Vcc	Speeds (ns)	Pkg (#Pins)	Status ⁽¹⁾⁽²⁾	Comment ^(4,5)
256K	32Kx8	IS62LV256	3.0V-3.6V	45, 70	SOJ(28),SOP(28),TSOP1(28)	Prod	
	32Kx8	IS62LV256L	3.0V-3.6V	15	SOJ(28),TSOP1(28)	Prod	
1M	64Kx16	IS62WV6416ALL/BLL	1.7V-3.6V	45, 55	TSOP2(44),mBGA(48)	Prod	L
	128Kx8	IS62WV1288ALL/BLL	1.65V-3.6V	45, 55	SOP(32),sTSOP1(32), TSOP1(32),mBGA(36)	Prod	L
2M	128Kx16	IS62WV12816ALL/BLL	1.65V-3.6V	45, 55,70	mBGA(48),TSOP2(44)	Prod	L, 2CS Option Avail.
	256Kx8	IS62WV2568ALL/BLL	1.65V-3.6V	55, 70	sTSOP1(32),TSOP1(32),mBGA(36)	Prod	L
4M	256Kx16	IS62V25616LL	1.65V-1.95V	70, 85	µBGA(48),TSOP2(44)	Prod	
	256Kx16	IS62WV25616ALL/BLL	1.65V-3.6V	55, 70	TSOP2(44),mBGA(48)	Prod	L
	512Kx8	IS62WV5128ALL/BLL	1.65V-3.6V	55, 70	sTSOP1(32),TSOP1(32), TSOP2(32),mBGA(36)	Prod	L
8M	512Kx16	IS62WV51216ALL/BLL	1.65V-3.6V	45, 55	mBGA(48),TSOP2(44)	Prod	L
	1MX8	IS62WV10248BLL	2.5V-3.6V	55, 70	mBGA(48)	Prod	L

PSEUDO SRAM

*Contact SRAM Marketing for questions

DYNAMIC RAM

5V EDO and Fast Page Mode DRAM

Den	Org	Type	Part No.	Vcc	Refsh	Ras (ns)	Pkg (#Pins)	Status ⁽¹⁾⁽²⁾	Comment ⁽³⁾
4M	256Kx16	EDO	IS41C16256	5V	128	35,60	SOJ(40),TSOP2(40/44)	Prod	NR
	256Kx16	EDO	IS41C16256A	5V	128	35,60	SOJ(40),TSOP2(40/44)	Prod	NR
	256Kx16	FP	IS41C16257	5V	128	35,60	SOJ(40),TSOP2(40/44)	Prod	NR
	256Kx16	FP	IS41C16257A	5V	128	35,60	SOJ(40),TSOP2(40/44)	Prod	NR
	512Kx8	EDO	IS41C85120	5V	128	50, 60	SOJ(28)	Prod	NR
	512Kx8	EDO	IS41C85120A	5V	128	50, 60	SOJ(28)	Prod	NR
	512Kx8	FP	IS41C85125	5V	128	50, 60	SOJ(28)	Prod	NR
	512Kx8	FP	IS41C85125A	5V	128	50, 60	SOJ(28)	Prod	NR
16M	1Mx16	EDO	IS41C16100	5V	1K	50, 60	SOJ(42),TSOP2(44/50)	Prod	NR
	1Mx16	FP	IS41C16105	5V	1K	50, 60	SOJ(42),TSOP2(44/50)	Prod	NR
	2Mx8	EDO	IS41C8200	5V	2K	50, 60	SOJ(28)	Prod	NR
	2Mx8	FP	IS41C8205	5V	2K	50, 60	SOJ(28)	Prod	NR
	4Mx4	EDO	IS41C44002	5V	2K	50, 60	SOJ(24/26)	Prod	NR
	4Mx4	EDO	IS41C44004	5V	4K	50, 60	SOJ(24/26)	Prod	NR
	4Mx4	FP	IS41C44052	5V	2K	50, 60	SOJ(24/26)	Prod	NR
	4Mx4	FP	IS41C44054	5V	4K	50, 60	SOJ(24/26)	Prod	NR

3.3V EDO and Fast Page Mode DRAM

Den	Org	Type	Part No.	Vcc	Refsh	Ras (ns)	Pkg (#Pins)	Status ⁽¹⁾⁽²⁾	Comment ^(3, 4)
4M	256Kx16	EDO	IS41LV16256A	3.3V	128	35,60	SOJ(40),TSOP2(40/44)	Prod	NR, L
	256Kx16	EDO	IS41LV16256B	3.3V	128	35,60	SOJ(40),TSOP2(40/44)	S=NOW	L
	256Kx16	FP	IS41LV16257A	3.3V	128	35,60	SOJ(40),TSOP2(40/44)	Prod	NR, L
	256Kx16	FP	IS41LV16257B	3.3V	128	35,60	SOJ(40),TSOP2(40/44)	S=NOW	L
	512Kx8	EDO	IS41LV85120A	3.3V	128	60	SOJ(28)	Prod	NR, L

Notes:

1. S = Sample 2. Prod = Production 3. NR = Not recommended for new design 4. L = Lead-free 5. 2CS = 2 chip enable
6. Items in **bold** are recommended samples and commonly ordered products as defined by ISSI

DYNAMIC RAM (CONT'D)

3.3V EDO and Fast Page Mode DRAM (Cont'd)

Den	Org	Type	Part No.	Vcc	Refsh	Ras (ns)	Pkg (#Pins)	Status ⁽¹⁾⁽²⁾	Comment ^(3,4)
4M	512Kx8	EDO	IS41LV85120B	3.3V	128	60	SOJ(28)	S=NOW	L
	512Kx8	FP	IS41LV85125A	3.3V	128	60	SOJ(28)	Prod	NR, L
	512Kx8	FP	IS41LV85125B	3.3V	128	60	SOJ(28)	S=NOW	L
16M	1Mx16	EDO	IS41LV16100A	3.3V	1K	50,60	SOJ(42), TSOP2(44/50)	Prod	NR, L
	1Mx16	EDO	IS41LV16100B	3.3V	1K	50,60	SOJ(42), TSOP2(44/50)	Prod	L
	1Mx16	FP	IS41LV16105A	3.3V	1K	50,60	SOJ(42), TSOP2(44/50)	Prod	NR, L
	1Mx16	FP	IS41LV16105B	3.3V	1K	50,60	SOJ(42), TSOP2(44/50)	Prod	L
	2Mx8	EDO	IS41LV8200A	3.3V	2K	50,60	SOJ(28)	Prod	NR, L
	2Mx8	EDO	IS41LV8200B	3.3V	2K	50,60	SOJ(28)	S=NOW	L
	2Mx8	FP	IS41LV8205A	3.3V	2K	50,60	SOJ(28)	Prod	NR, L
	2Mx8	FP	IS41LV8205B	3.3V	2K	50,60	SOJ(28)	S=NOW	L
	4Mx4	EDO	IS41LV44002A	3.3V	2K	50,60	SOJ(24/26)	Prod	NR, L
	4Mx4	EDO	IS41LV44002B	3.3V	2K	50,60	SOJ(24/26)	S=NOW	L

3.3V SDR (Single Data Rate) Synchronous DRAM

Den	Org	Type	Part No.	Vcc	Refsh	Speed (Mhz)	Pkg (#Pins)	Status ⁽¹⁾⁽²⁾	Comment ^(3,4)
16M	1Mx16	SDR	IS42S16100A1	3.3V	2K	166,143,100	TSOP2(50)	Prod	NR
	1Mx16	SDR	IS42S16100C1	3.3V	2K	200,166,143	TSOP2(50)	Prod	L
	1Mx16	SDR	IS42S16100D	3.3V	2K	143	TSOP2(50)	S=NOW	L
64M	4Mx16	SDR	IS42S16400B	3.3V	4K	166,143	TSOP2(54)	Prod	L
	4Mx16	SDR	IS42S16400C1	3.3V	4K	166,143	TSOP2(54)	S=NOW	L
	2Mx32	SDR	IS42S32200B	3.3V	4K	166,143	TSOP2(86)	Prod	L
	2Mx32	SDR	IS42S32200C1	3.3V	4K	166,143	TSOP2(86)	S=NOW	L
128M	16Mx8	SDR	IS42S81600A	3.3V	4K	166,143,100	TSOP2(54)	Prod	NR
	8Mx16	SDR	IS42S16800A	3.3V	4K	166,143,100	TSOP2(54)	Prod	NR
	4Mx32	SDR	IS42S32400A	3.3V	4K	166,143,100	TSOP2(86)	Prod	NR
	16Mx8	SDR	IS42S81600B	3.3V	4K	167,143,125	TSOP2(54)	S=NOW	L
	8Mx16	SDR	IS42S16800B	3.3V	4K	167,143,125	TSOP2(54)	S=NOW	L
	4Mx32	SDR	IS42S32400B	3.3V	4K	167,143,125	TSOP2(86), fBGA(90)	S=NOW	L
256M	32Mx8	SDR	IS42S83200A	3.3V	8K	133	TSOP2(54)	Prod	L
	16Mx16	SDR	IS42S16160A	3.3V	8K	166, 143	TSOP2(54)	Prod	L

2.5V DDR (Double Data Rate) Synchronous DRAM

Den	Org	Type	Part No.	Vcc	Refsh	Speed (Mhz)	Pkg (#Pins)	Status ⁽¹⁾⁽²⁾	Comment ⁽⁴⁾
128M	4Mx32	DDR	IS43R32400	2.5V	8K	200	FBGA(144)	S=NOW	L
256M	16Mx16	DDR	IS43R16160A	2.5V	8K	166,143	TSOP2(66)	S=NOW	L

2.5V-3.3V PowerSaver™ Low Power Synchronous DRAM

Den	Org	Type	Part No.	Vcc	Refsh	Speed (Mhz)	Pkg (#Pins)	Status ⁽¹⁾⁽²⁾	Comment ⁽³⁾
128M	8Mx16	SDR	IS42S16800AL	3.3V	4K	133,100	TSOP2(54)	Prod	NR
	4Mx32	SDR	IS42S32400AL	3.3V	4K	133,100	TSOP2(86)	Prod	NR

1.8V PowerSaver™ Low Power Synchronous DRAM

Den	Org	Type	Part No.	Vcc	Refsh	Speed (Mhz)	Pkg (#Pins)	Status ⁽¹⁾⁽²⁾	Comment ⁽⁴⁾
16M	1Mx16	SDR	IS42VS16100C1	1.8V	2K	100	TSOP2(50)	S=NOW	L, die avail.
	1Mx16	SDR	IS42VS16100D	1.8V	2K	133,100,83	TSOP2(50)	S=NOW	L, die avail.

Notes: 1. S = Sample 2. Prod = Production 3. NR = Not recommended for new design 4. L = Lead-free

SEARCH PROCESSOR

Parallel

Den	Org ⁽³⁾⁽⁴⁾	Part No.	Vcc	Speed (Mhz)	Pkg (#Pins)	Status ⁽¹⁾⁽²⁾	Comment
4Mb	64x1Kx64(B)/32(T)	IS51VV4064	1.8V	66,83,100,133	BGA(480)	S=NOW	

BLUETOOTH™ ICs

Wireless RF Chipset Solutions

Part No.	Vcc	Pkg (#Pins)	Status ⁽¹⁾⁽²⁾	Comment
IS11LV5210	2.5V	QFN(48)	S=NOW	2.4 GHz RF Transceiver

SMART CARDS

Serial Memory

Den	Org	Part No.	Vcc	Speed (Khz)	Pkg	Status ⁽¹⁾⁽²⁾	Comment
1K	128x8	IS24C01-3	2.5V-5.5V	400	die, wafer, module	Prod	
2K	256x8	IS24C02A-3	2.5V-5.5V	400	die, wafer, module	Prod	
4K	512x8	IS24C04A-3	2.5V-5.5V	400	die, wafer, module	Prod	
8K	1024x8	IS24C08A-3	2.5V-5.5V	400	die, wafer, module	Prod	
16K	2Kx8	IS24C16A-3	2.5V-5.5V	400	die, wafer, module	Prod	
32K	4Kx8	IS24C32A-3	2.5V-5.5V	400	die, wafer, module	Prod	
64K	8Kx8	IS24C64A-3	2.5V-5.5V	400	die, wafer, module	Prod	
128K	16Kx8	IS24C128-3	2.5V-5.5V	400	die, wafer, module	Prod	
256K	32Kx8	IS24C256-3	2.5V-5.5V	400	die, wafer, module	S=Q1/06	

Secure Serial, EEPROM

Den	Org	Part No.	Vcc	Speed	Pkg	Status ⁽¹⁾⁽²⁾	Comment
2K	256x8 EEPROM	IS23SC4442	2.5V	N / A	die, wafer, module	Prod	
8K	1Kx8 EEPROM	IS23SC4428	2.5V	N / A	die, wafer, module	Prod	
16K	2Kx8 EEPROM	IS23SC1604	2.5V	N / A	die, wafer, module	Prod	

MCU Based Smart Card IC

Den	Org	Part No.	Vcc	Speed	Pkg	Status ⁽¹⁾⁽²⁾	Comment
8K	8 bit MCU w/8K byte EEPROM	IS23SC4408	3V-5V	N / A	die, wafer, module	Prod	16KB ROM
16K	8 bit MCU w/16K byte EEPROM	IS23SC4416	3V-5V	N / A	die, wafer, module	S=Q2/05	48KB ROM
32K	8 bit MCU w/32K byte EEPROM	IS23SC4432	3V-5V	N / A	die, wafer, module	S=Q1/06	32KB ROM

Notes:

1. S = Sample 2. Prod = Production 3. (B) = binary 4. (T) = ternary
5. Items in **bold** are recommended samples and commonly ordered products as defined by ISSI

EEPROM

Microwire Serial EEPROM

Den	Org	Part No.	Vcc	Speed (Mhz)	Pkg (#Pins)	Status ⁽¹⁾⁽²⁾	Comment
1K	128x8/64x16	IS93C46A	2.5V-5.5V	2	PDIP(8),SOIC(8),TSSOP(8)	Prod	
	64x16	IS93C46B	2.5V-5.5V	2	PDIP(8),SOIC(8)	Prod	
	128x8/64x16	IS93C46D	1.8V-5.5V	1	PDIP(8),SOIC(8),TSSOP(8)	S=Q4/05	
2K	256x8/128x16	IS93C56A	1.8V-5.5V	2	PDIP(8),SOIC(8),TSSOP(8)	S=Q3/05	
4K	512x8/256x16	IS93C66A	1.8V-5.5V	2	PDIP(8),SOIC(8),TSSOP(8)	Prod	
8K	1Kx8/512x16	IS93C76A	1.8V-5.5V	2	PDIP(8),SOIC(8),TSSOP(8)	Prod	
16K	2Kx8/1Kx16	IS93C86A	1.8V-5.5V	2	PDIP(8),SOIC(8),TSSOP(8)	Prod	

Two-Wire Serial EEPROM

Den	Org	Part No.	Vcc	Speed (Khz)	Pkg (#Pins)	Status ⁽¹⁾⁽²⁾	Comment ⁽³⁾⁽⁴⁾
1K	128x8	IS24C01	1.8V-5.5V	400	PDIP(8),SOIC(8),TSSOP(8),MSOP(8)	Prod	
	128x8	IS24C01B	1.8V-5.5V	400	PDIP(8),SOIC(8),TSSOP(8),MSOP(8)	S=Q3/05	
2K	256x8	IS24C02	1.8V-5.5V	400	PDIP(8),SOIC(8),TSSOP(8),MSOP(8)	Prod	
	256x8	IS24C02B	1.8V-5.5V	400	PDIP(8),SOIC(8),TSSOP(8)	Prod	
	256x8	IS34C02	1.8V-5.5V	400	SOIC(8),TSSOP(8),MSOP(8)	Prod	PWP
4K	512x8	IS24C04A	1.8V-5.5V	400	PDIP(8),SOIC(8),TSSOP(8),MSOP(8)	Prod	
8K	1024x8	IS24C08A	1.8V-5.5V	400	PDIP(8),SOIC(8),TSSOP(8),MSOP(8)	Prod	
16K	2Kx8	IS24C16A	1.8V-5.5V	400	PDIP(8),SOIC(8),TSSOP(8),MSOP(8)	Prod	
32K	4Kx8	IS24C32A	1.8V-5.5V	400	PDIP(8),SOIC(8),TSSOP(8)	Prod	
	4Kx8	IS24C32B	1.8V-5.5V	400	PDIP(8),SOIC(8),TSSOP(8)	S=NOW	QAWP
64K	8Kx8	IS24C64A	1.8V-5.5V	400	PDIP(8),SOIC(8),TSSOP(8)	Prod	
	8Kx8	IS24C64B	1.8V-5.5V	400	PDIP(8),SOIC(8),TSSOP(8)	Prod	QAWP
128K	16Kx8	IS24C128	2.5V-5.5V	400	PDIP(8),SOIC(8),TSSOP(14)	Prod	
256K	32Kx8	IS24C256	1.8V-5.5V	400	PDIP(8),SOIC(8),TSSOP(14)	S=Q4/05	

SPI (Serial Peripheral Interface) EEPROM

Den	Org	Part No.	Vcc	Speed(Mhz)	Pkg(#Pins)	Status ⁽¹⁾⁽²⁾	Comment
1K	128x8	IS25C01	1.8V-5.5V	5	PDIP(8),SOIC(8),TSSOP(8)	S=NOW	
2K	256x8	IS25C02	1.8V-5.5V	5	PDIP(8),SOIC(8),TSSOP(8)	S=NOW	
4K	512x8	IS25C04	1.8V-5.5V	5	PDIP(8),SOIC(8),TSSOP(8)	S=NOW	
8K	1Kx8	IS25C08	1.8V-5.5V	5	PDIP(8),SOIC(8),TSSOP(8)	Prod	
16K	2Kx8	IS25C16	1.8V-5.5V	5	PDIP(8),SOIC(8),TSSOP(8)	Prod	
32K	4Kx8	IS25C32A	1.8V-5.5V	5	PDIP(8),SOIC(8),TSSOP(8)	S=Q3/05	
64K	8Kx8	IS25C64A	1.8V-5.5V	5	PDIP(8),SOIC(8),TSSOP(8)	S=Q3/05	
128K	16Kx8	IS25C128	1.8V-5.5V	5	SOIC(8),TSSOP(8)	S=Q4/05	
256K	32Kx8	IS25C256	1.8V-5.5V	5	SOIC(8),TSSOP(8)	S=Q4/05	

Notes:

1. S = Samples 2. Prod = Production 3. PWP = Permanent Write-Protection 4. QAWP = Quarter Array Write Protection

AUTOMOTIVE MEMORY PRODUCTS

Automotive Synchronous SRAM

Den	Org	Part No. ⁽⁵⁾	Vcc	VccQ	Speed (Mhz)	tKQ (ns)	Pkg (#Pins)	Status ⁽¹⁾⁽²⁾	Comment ⁽³⁾⁽⁴⁾
2M	64Kx32	IS64LF6432	3.3V	2.5V/3.3V	90,66	8.5,10	TQFP(100)	Prod	F
	64Kx36	IS64LF6436	3.3V	2.5V/3.3V	90,66	8.5,10	TQFP(100)	Prod	F
4M	128Kx32	IS64LPS12832A	3.3V	2.5V/3.3V	150	4.3	TQFP(100),PBGA(119)	S=NOW	P
	128Kx32	IS64LF12832A	3.3V	2.5V/3.3V	150	4.3	TQFP(100),PBGA(119)	S=NOW	P
	128Kx36	IS64LPS12836A	3.3V	2.5V/3.3V	150	4.3	TQFP(100),PBGA(119)	S=NOW	P

Automotive Asynchronous SRAM

Den	Org	Part No. ⁽⁵⁾	Vcc	Speeds (ns)	Pkg (#Pins)	Status ⁽¹⁾⁽²⁾	Comment ⁽⁶⁾
256K	32Kx8	IS65C256	4.5V-5.5V	20	SOP(28) ,TSOP1(28)	Prod	
1M	64Kx16	IS64LV6416AL	2.6V	20	TSOP2(44) ,mBGA(48),LQFP(44)	Prod	Typ. Isb is 4uA
	64Kx16	IS64LV6416L	3.3V	10,12	TSOP2(44) ,mBGA(48)	Prod	
	64Kx16	IS64C6416AL	4.5V-5.5V	15	SOJ(44), TSOP2(44)	Prod	
	128Kx8	IS64C1024AL	5.0V	15	SOJ(32.4),TSOP1(32)	Prod	
	128Kx8	IS65C1024AL	5.0V	45	SOP(32),TSOP1(32)	Prod	
2M	128Kx16	IS65WV12816ALL/BLL	1.65V-3.6V	55,70	TSOP2(44) ,mBGA(48)	S=NOW	
	128Kx16	IS64WV12816BLL	2.5V-3.6V	15	TSOP2(44) ,mBGA(48)	Prod	
4M	256Kx16	IS64LV25616AL	3.3V	10,12	TSOP2(44) ,mBGA(48)	Prod	L
	256Kx16	IS65WV25616ALL/BLL	1.65V-3.3V	55,70	TSOP2(44)	S=NOW	

Automotive Serial EEPROM

Den	Org	Type	Part No. ⁽⁵⁾	Vcc	Speed (Mhz)	Pkg (#Pins)	Status ⁽¹⁾⁽²⁾	Comment
1K	128x8	I ² C	IS24C01B	2.5V-5.5V	1	SOIC(8), PDIP(8), TSSOP(8)	S=Q3/05	
	128x8	SPI	IS25C01	2.5V-5.5V	10	SOIC(8), PDIP(8), TSSOP(8)	S=Q3/05	
	128x8/64x16	Microwire	IS93C46D	2.5V-5.5V	3	SOIC(8), PDIP(8), TSSOP(8)	S=Q4/05	
2K	256x8	I ² C	IS24C02A	2.5V-5.5V	1	SOIC(8), PDIP(8), TSSOP(8)	S=NOW	
	256x8	SPI	IS25C02	2.5V-5.5V	10	SOIC(8), PDIP(8), TSSOP(8)	S=NOW	
	256x8/128x16	Microwire	IS93C56A	2.5V-5.5V	3	SOIC(8), PDIP(8), TSSOP(8)	S=Q3/05	
4K	512x8	I ² C	IS24C04A	2.5V-5.5V	1	SOIC(8), PDIP(8), TSSOP(8)	S=NOW	
	512x8	SPI	IS25C04	2.5V-5.5V	10	SOIC(8), PDIP(8), TSSOP(8)	S=Q3/05	
	512x8/256x16	Microwire	IS93C66A	2.5V-5.5V	3	SOIC(8), PDIP(8), TSSOP(8)	S=NOW	
8K	1Kx8	I ² C	IS24C08A	2.5V-5.5V	1	SOIC(8), PDIP(8), TSSOP(8)	S=NOW	
	1Kx8	SPI	IS25C08	2.5V-5.5V	10	SOIC(8), PDIP(8), TSSOP(8)	S=NOW	
	1Kx8/512x16	Microwire	IS93C76A	2.5V-5.5V	3	SOIC(8), PDIP(8), TSSOP(8)	S=NOW	
16K	2Kx8	I ² C	IS24C16A	2.5V-5.5V	1	SOIC(8), PDIP(8), TSSOP(8)	S=NOW	
	2Kx8	SPI	IS25C16	2.5V-5.5V	10	SOIC(8), PDIP(8), TSSOP(8)	S=NOW	
	2Kx8/1Kx16	Microwire	IS93C86A	2.5V-5.5V	3	SOIC(8), PDIP(8), TSSOP(8)	S=NOW	
32K	4Kx8	I ² C	IS24C32A	2.5V-5.5V	1	SOIC(8), PDIP(8), TSSOP(8)	S=Q3/05	
	4Kx8	SPI	IS25C32A	2.5V-5.5V	10	SOIC(8), PDIP(8), TSSOP(8)	S=Q3/05	
64K	8Kx8	I ² C	IS24C64A	2.5V-5.5V	1	SOIC(8), PDIP(8), TSSOP(8)	S=Q3/05	
	8Kx8	SPI	IS25C64A	2.5V-5.5V	10	SOIC(8), PDIP(8), TSSOP(8)	S=Q3/05	

Notes:

1. S = Samples 2. Prod = Production 3. P = Pipeline 4. F = Flow Through
5. Available in automotive temperature grade of -40°C to +125°C. 6. L = Lead-free
7. Items in **bold** are recommended samples and commonly ordered products as defined by ISSI

ORDERING INFORMATION FOR ISSI DEVICES

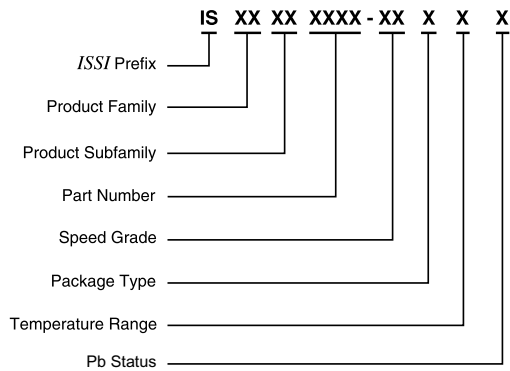

Product Family:

- 1X** = Bluetooth™
- 2X** = Secure Serial EEPROM/ Smart Card IC's
- 4X** = DRAM
- 5X** = Search Processor
- 6X** = SRAM
- 9X** = Microwire EEPROM

Temperature Range:

- Blank** = Commercial (0°C to +70°C)
- I** = Industrial (-40°C to +85°C)
- A** = Automotive (0°C to +70°C)
- A1** = Automotive (-40°C to +85°C)
- A2** = Automotive (-40°C to +105°C)
- A3** = Automotive (-40°C to +125°C)

Pb Status:

- Blank** = Normal
- L** = Pb Free

Package Type:

- A** = mBGA
- B** = PBGA or mBGA
- D** = BGA
- F** = uBGA
- G** = JEDEC SOIC (Rotated)
- GR** = JEDEC SOIC
- H** = STSOP
- J** = 300-mil Plastic SOJ
- K** = 400-mil Plastic SOJ
- LQ** = LQFP
- M** = μ BGA (6x8mm, 7.2x8.7mm or 9mm x 11mm)
- P** = 300-mil Plastic DIP (8-pin)
- PL** = PLCC
- PQ** = PQFP
- Q** = 450-mil SOP
- QF** = QFN
- S** = 120-mil MSOP
- T** = TSOP
- TQ** = TQFP
- U** = 330-mil Plastic SOP
- V** = TSPOP
- X** = Unpackaged Die
- Z** = TSSOP

ICSI PRODUCT FAMILY



ICSI SYNCHRONOUS SRAM

Zero Wait Synchronous SRAM

Den	Org	Part No.	Vcc(VccQ)	Speeds (ns)	Pkg (#Pins)	Status ⁽¹⁾⁽²⁾	Comment
2M	64K x 32	IC61ZW6432	3.3V	5,6,7,8	TQ (100)	Prod	compatible to ZBT

Flow Through Synchronous SRAM

Den	Org	Part No.	Vcc(VccQ)	Speeds (ns)	Pkg (#Pins)	Status ⁽¹⁾⁽²⁾	Comment
2M	64K x 32	IS61SF6432	3.3V	10	PQ,TQ (100)	Prod	
4M	128K x 32	IC61SF12832	3.3V	10,12	TQ (100)	Prod	
4M	128K x 36	IC61SF12836	3.3V	10,12	TQ (100)	Prod	
8M	256K x 32	IC61SF25632D	3.3V	6.5, 7.5, 8.5, 9.5,	TQ (100), B (119)	Prod	2CE
8M	256K x 32	IC61SF25632T	3.3V	6.5, 7.5, 8.5, 9.5,	TQ (100)	Prod	3CE
8M	256K x 36	IC61SF25636D	3.3V	6.5, 7.5, 8.5, 9.5,	TQ (100)	Prod	2CE
8M	256K x 36	IC61SF25636T	3.3V	6.5, 7.5, 8.5, 9.5,	TQ (100)	Prod	3CE
8M	512K x 18	IC61SF51218D	3.3V	6.5, 7.5, 8.5, 9.5,	TQ (100), B (119)	Prod	2CE
8M	512K x 18	IC61SF51218T	3.3V	6.5, 7.5, 8.5, 9.5,	TQ (100)	Prod	3CE

Pipeline Synchronous SRAM

Den	Org	Part No.	Vcc(VccQ)	Speeds (ns)	Pkg (#Pins)	Status ⁽²⁾⁽³⁾	Comment
1M	32Kx32	IC61C6232A	3.3V	125, 100 (MHZ)	PQ,TQ (100)	EOL	
2M	64K x 32	IC61LV6432	3.3V	166,133,117(MHz) 5,6,7,8	PQ,TQ (100)	Prod	2.5V I/O
2M	64K x 32	IC61S6432	3.3V	200,166,133,117(MHz), 5,6,7,8	PQ,TQ (100)	Prod	
4M	128K x 32	IC61SP12832	3.3V	166,150,133,117(MHz), 5	TQ (100)	Prod	
4M	128K x 36	IC61SP12836	3.3V	166,150,133,117(MHz), 5	TQ (100)	Prod	
8M	256K x 32	IC61S25632D	3.3V	250,200,166,133(MHz)	TQ (100)	Prod	2CE
8M	256K x 32	IC61S25632T	3.3V	250,200,166,133(MHz)	TQ (100)	Prod	3CE
8M	256K x 36	IC61S25636D	3.3V	250,200,166,133(MHz)	TQ (100), B (119)	Prod	2CE
8M	256K x 36	IC61S25636T	3.3V	250,200,166,133(MHz)	TQ (100)	Prod	3CE
8M	512K x 18	IC61S51218D	3.3V	250,200,166,133(MHz)	TQ (100)	Prod	2CE
8M	512K x 18	IC61S51218T	3.3V	250,200,166,133(MHz)	TQ (100)	Prod	3CE

ICSI PSEUDO SRAM

Den	Org	Part No.	Vcc(VccQ)	Speeds (ns)	Pkg (#Pins)	Status ⁽¹⁾⁽²⁾	Comment
4M	256K x 16	IC66LV25616L	2.7V-3.3V	70,100	B (48)	Engineering	
8M	512K x 16	IC66LV51216L	2.7V-3.3V	70,100	B (48)	Engineering	
16M	1M x16	IC66LV10016AL	2.7V-3.3V	70,100	B (48)	Prod	

Notes:

1. S = Samples 2. Prod = Production 3. EOL = End of Life

ICSI ASYNCHRONOUS SRAM

Low-Speed Asynchronous SRAM

Den	Org	Part No.	Vcc(VccQ)	Speeds (ns)	Pkg (#Pins)	Status ⁽¹⁾⁽²⁾	Comment
256K	32K x 8	IC62C256	5V	45,70	T,TG,U,UG (28)	Prod	
1M	128K x 8	IC62C1024	5V	45,70	T (32)	Prod	
1M	128K x 8	IC62C1024A	5V	45,55,70	Q,T,W (32)	Prod	
1M	128K x 8	IC62C1024AL	5V	45,55,70	Q,T,W (32)	Prod	
1M	128K x 8	IC62C1024L	5V	45,55,70	Q,T,W (32)	Prod	

Low Power Asynchronous SRAM

Den	Org	Part No.	Vcc(VccQ)	Speeds (ns)	Pkg (#Pins)	Status ⁽³⁾	Comment
256K	32K x 8	IC62LV256	3.3V	45,70,100	T,U (28)	EOL	
256K	32K x 8	IS62LV256L	3.3V	15,20,	J,JG,T,TG (28)	EOL	

Low Low Power Asynchronous SRAM

Den	Org	Part No.	Vcc(VccQ)	Speeds (ns)	Pkg (#Pins)	Status ⁽¹⁾⁽²⁾	Comment
1M	128K x 8	IC62LV1024LL	2.7V-3.6V	55,70	T (32)	Prod	
2M	128K x 16	IC62LV12816LL	2.7V-3.6V	55,70,100	T,TG (44), B (48)	Prod	
2M	128K x 16	IC62VV12816LL	1.65V-2.2V	70,85	B (48)	Prod	
2M	256K x 8	IC62LV2568LL	2.7V-3.6V	55,70,100	H,HG,T (32), B (36/48)	Prod	
2M	256K x 8	IC62VV2568LL	1.65V-2.2V	70	T(32)	Prod	
4M	256K x 16	IC62LV25616LL	2.7V-3.6V	55,70,100	T,TG (44), B (48)	Prod	
4M	256K x 16	IC62VV25616LL	1.65V-2.2V	70,100	T (44), B (48)	Prod	
4M	512K x 8	IC62LV5128LL	2.7V-3.6V	55,70,100	H,HG,T (32), B (36/48)	Prod	
4M	512K x 8	IC62VV5128LL	1.65V-2.2V	70	B (36/48)	Prod	
8M	512K x 16	IC62LV51216LL	2.7V-3.6V	55,70	T,TG (44), B (48)	Prod	
8M	512K x 16	IC62VV51216LL	1.65V-2.2V	70,100	T (44), B (48)	Prod	
8M	1M x 8	IC62LV1008LL	2.7V-3.6V	70,100	B (48)	Prod	
8M	1M x 8	IC62VV1008LL	1.65V-2.2V	70,100	B (48)	Prod	

High Speed Asynchronous SRAM

Den	Org	Part No.	Vcc(VccQ)	Speeds (ns)	Pkg (#Pins)	Status ⁽¹⁾⁽²⁾	Comment
256K	32K x 8	IC61LV256	3.3V	8, 10, 12, 15	J,JG,T,TG (28)	Prod	
256K	32K x 8	IC61C256AH	5V	10,12,15,20	J,JG,N,T,TG,U,UG (28)	Prod	
1M	64K x 16	IC61LV6416	3.3V	8, 10, 12, 15	K,KG,T,TG (44), B (48)	Prod	
1M	64K x 16	IC61C6416	5V	15,20	K,T,TG (44)	Prod	
1M	128K x 8	IC61C1024	5V	12, 15, 20	J,JG,K,T,TG (32)	Prod	
1M	128K x 8	IC61C1024L	5V	15, 20	J,K,T (32)	Prod	
1M	128K x 8	IC63LV1024	3.3V	8, 10, 12, 15	J,K,KG,T,TG (32), B (36/48)	Prod	
2M	128K x 16	IC61LV12816	3.3V	10, 12, 15	T,TG (44), B (48)	Prod	
2M	256K x 8	IC61LV2568	3.3V	10, 12, 15	K (36) , T (44)	Prod	
4M	256K x 16	IC61LV25616	3.3V	8, 10, 12, 15	K (44), T,TG (48), B(48),	Prod	
4M	512K x 8	IC61LV5128	3.3V	8, 10, 12, 15	K (36), T,TG (44)	Prod	

Notes:

1. S = Samples 2. Prod = Production 3. EOL = End of Life

ICSI DRAM

DDR

Den	Org	Part No.	Vcc(VccQ)	Speeds (ns)	Pkg (#Pins)	Status ⁽¹⁾⁽²⁾	Comment
128M	4MX32	IC43R32400	2.5V	5	144-Ball FBGA	Prod	
256M	16MX16	IC43R16160	2.5V	6,7	T/TG(66)	Prod	

SDRAM

Den	Org	Part No.	Vcc(VccQ)	Speeds (ns)	Pkg (#Pins)	Status ⁽¹⁾⁽²⁾	Comment
16M	1MX16	IC42S16100	3.3V	5,6,7	T/TG(50),B/BG(60)	Prod	
16M	1MX16	IC42S16101	3.3V	5,6,7	T/TG(50),B/BG(60)	Prod	
16M	1MX16	IC42S16102	3.3V	5,6	T/TG(50),B/BG(60)	Prod	
64M	2MX32	IC42S32200	3.3V	6,7	T/TG(86),B/BG(90)	Prod	
64M	2MX32	IC42S32200L	3.3V	6,7	T/TG(86),B/BG(90)	Prod	
64M	2MX32	IC42S32202	3.3V	6,7	T/TG(86),B/BG(90)	Prod	
64M	4MX16	IC42S16400	3.3V	6,7	T/ TG(54),B/BG(60)	Prod	
64M	4MX16	IC42S16400A	3.3V	6,7	T/ TG(54)	Prod	
128M	4MX32	IC42S32400	3.3V	6,7	T/TG(86),B/BG(90)	Prod	
128M	8MX16	IC42S16800A	3.3V	6,7	T(54)	Prod	
128M	8MX16	IC42S16800	3.3V	6,7	T/TG(54)	Prod	
128M	8MX16	IC42S16800L	3.3V	6,7	T/TG(54)	Prod	
128M	16MX8	IC42S81600	3.3V	6,7	T/TG(54)	Prod	
128M	16MX8	IC42S81600L	3.3V	6,7	T/TG(54)	Prod	
256M	16MX16	IC42S16160	3.3V	6,7	TG(54)	Prod	

EDO DRAM

Den	Org	Part No.	Vcc(VccQ)	Speeds (ns)	Pkg (#Pins)	Status ⁽²⁾	Comment ⁽³⁾
4M	256KX16	IC41C16256	5V	25,35,50	T/TG(40/44), K/KG(40)	Prod	
4M	256KX16	IC41LV16256	3.3V	35,50	T/TG(40/44), K/KG(40)	Prod	
4M	512KX8	IC41C8512	5V	35,50	T/TG(28)K/KG(28)	Prod	NR
4M	512KX8	IC41LV8512	3.3V	35,50	T/TG(28)K/KG(28)	Prod	NR
16M	1MX16	IC41C16100S	5V	50	K/KG(42),T/TG(44/50)	Prod	
16M	1MX16	IC41LV16100S	3.3V	50	K/KG(42),T/TG(44/50)	Prod	
16M	2MX8	IC41C82002S	5V	50	J(28)	Prod	NR
16M	2MX8	IC41LV82002S	3.3V	50	J(28)	Prod	NR
16M	4MX4	IC41C44002	5V	50	J/JG/T/TG(24/26)	Prod	
16M	4MX4	IC41C44002A	5V	50,60	J/T(24/26)	Prod	
16M	4MX4	IC41C44004	5V	50	J/T(24/26)	Prod	
16M	4MX4	IC41LV44002	3.3V	50	JG/TG(24/26)	Prod	
16M	4MX4	IC41LV44004	3.3V	50	JG/TG(24/26)	Prod	

Notes:

1. S = Samples 2. Prod = Production 3. NR = Not recommended for new design

ICSI DRAM (CONT'D)

FPM DRAM

Den	Org	Part No.	Vcc(VccQ)	Speeds (ns)	Pkg (#Pins)	Status ⁽²⁾	Comment ⁽³⁾
4M	256KX16	IC41C16257	5V	35,50	T/TG(40/44), K/KG(40)	Prod	
4M	256KX16	IC41LV16257	3.3V	35,50	T/TG(40/44), K/KG(40)	Prod	
4M	512KX8	IC41C8513	5V	35,50	T/TG(28)K/KG(28)	Prod	NR
4M	512KX8	IC41LV8513	3.3V	35,50	T/TG(28)K/KG(28)	Prod	NR
4M	1MX4	IC41SV4105	1.9V-2.4V	100	T/TG(20/26)	Prod	NR
16M	1MX16	IC41C16105	5V	50	K/KG(42), T/TG(44//50)	Prod	
16M	1MX16	IC41C16105S	5V	50	K/KG(42), T/TG(44//50)	Prod	
16M	1MX16	IC41LV16105	3.3V	50	K/KG(42), T/TG(44//50)	Prod	
16M	1MX16	IC41LV16105S	3.3V	50	K/KG(42), T/TG(44//50)	Prod	
16M	2MX8	IC41C82052S	5V	50	J/JG/T/TG(28)	Prod	NR
16M	2MX8	IC41LV82052S	3.3V	50	J/JG/T/TG(28)	Prod	NR
16M	4MX4	IC41C44052	5V	50	J/JG(T/TG(24/26)	Prod	
16M	4MX4	IC41C44054	5V	50	J/JG(T/TG(24/26)	Prod	
16M	4MX4	IC41LV44052	3.3V	50	JG/TG(24/26)	Prod	
16M	4MX4	IC41LV44054	3.3V	50	JG/TG(24/26)	Prod	
16M	4MX4	IC41SV44052	1.9V-2.7V	70,100	J/JG(T/TG(24/26)	Prod	

ICSI LOGIC

Flash Card Controller Product Family

Part No.	Function	Volt Reg.	LVD	Crystal	ECC ⁽⁴⁾	Operation Range	Code Storage	Flash Supported	Flash Size Supported	ISP	Status ⁽¹⁾⁽²⁾
IC1700-F100TQ	CF Card Controller		V		ECC1	3.3V-5V	Embed Flash	NAND/AND	8MB-8GB	PCMCIA	Prod
IC1701-F100TQ	CF Card Controller	V	V	V	ECC2	3.3V-5V	Embed Flash	NAND/AND/AG-AND	8MB-8GB	PCMCIA	Prod
IC1710-F48QN	SD/MMC Card Controller	V	V	V	ECC2	3.3V	Embed Flash	NAND/AND/AG-AND	8MB-4GB	SPI	Prod
IC1720-F100TQ	CF+USB1.1 Card Controller	V	V	V	ECC2	3.3V-5V	Embed Flash	NAND/AND/AG-AND	8MB-8GB	PCMCIA	Prod
IC1721-F48Q/F64Q	USB2.0 Flash Disk Controller	V		V	ECC3	3.3V	Embed Flash	NAND/AND/AG-AND	8MB-8GB	USB	Prod
IC1711-F48QN	SD/MMC Card Controller	V	V	V	ECC3	3.3V	Embed Flash	NAND/AND/AG-AND	8MB-8GB	SPI	S

Image Product Family

Part No.	Application	Vcc	Resolution	System Interface	Status
IC3150-64TQ	USB 2.0 PC Camera	3.0V-3.6V	Up to 1.3M Pixel resolution	USB 2.0	Prod
IC3160-64TQ	USB 2.0 TV Tuner	3.0V-3.6V	NTSC/PAL resolution	USB 2.0	Prod

Notes:

1. S = Samples 2. Prod = Production 3. NR = Not recommended for new design
4. ECC1 : 1-bit correct, 2-bit detect within 256 byte
ECC2 : 2 random bytes correct, 3 bytes detect within 512 byte
ECC3 : 4 random bytes correct, 5 bytes detect within 512 byte

ICSI LOGIC (CONT'D)

Audio Product Family

Part No.	Application	Vcc	Audio Decoder	Voice Recorder	16-bit Sigma-delta ADC	18-bit Sigma-delta DAC	Earphone Amplifier	Interface	Pkg (Pin#)	Status ⁽²⁾
IC2201-28S	MP3 Player	2.5V-3.6V	MPEG 1, 2 layer 3			V	V	IIS Interface	SOP 28-pin	Prod
IC2201B-48LQ	MP3 Player	2.5V-3.6V	MPEG 1, 2 layer 3			V	V	IIS Interface	LQFP 48-pin	Prod
IC2202-48LQ	MP3 Player	2.5V-3.6V	MPEG 1, 2 layer 3	ADPCM	V	V	V	IIS Interface	LQFP 48 pin	Prod

Part No.	Function	USB ⁽³⁾	SM xD	Max. NAND/MLC Flash Size	SD MMC	MS Ms-Duo	MS-Pro	MP3	LCM	Code Storage	ISP	Pkg (Pin#)	Status ⁽²⁾
IC1115-F64LQ	Flash Card/	1.1	V	4/2 Gbit	V	V	V	V	Segment	32KB Embed	USB1.1 I ² C	LQFP 64-pin	Prod
IC1115-M64LQ	NAND	1.1	V	4/2 Gbit	V	V	V	V	Segment	32KB Mask ROM	I ² C	LQFP 64-pin	Prod
IC1215-F64LQ	Flash Based	2.0		4/2 Gbit	V			V	Segment	64KB Embed Flash	USB2.0 I ² C	LQFP 64-pin	Prod
IC1218-F128LQ	MP3 Controller	2.0		4/2 Gbit	V			V	Dot Matrix Segment	64KB Embed Flash	USB2.0 I ² C	LQFP 128-pin	Prod

Databank Family

Part	Function	ROM Code	USB Device	ATAPI Host	CF	SM/xD/ NAND/MLC	SD/MMC	MS/MS-Duo MS-Pro	MP3	ISP	MP Status ⁽²⁾
IC1211-128LQ	USB2.0 Databank	32K	USB2.0	V	V	V	V	V	V	I ² C	Prod

USB1.1 Flash Card Reader Family

Part	Function	CF	SM/xD/ NAND/MLC	SD/MMC	MS/ MS-Duo	MS-Pro	MP3	Code Storage	ISP	Embedded Functions	Status ⁽²⁾
IC1110-F128LQ	USB1.1 All in One Card Reader	V	V	V	V	1bitbus	V	32KB Embed Flash	USB1.1&2.0 /I ² C		Prod
IC1110-M128LQ	USB1.1 All in One Card Reader	V	V	V	V	V	V	32KB Mask ROM	USB1.1&2.0 /I ² C	Regulator; Power Switch; Pad resistors	Prod
IC1113-F48LQ	USB1.1 MS/MS-Pro/ SD/MMC Card Reader			V	V	1bitbus	V	32KB Embed Flash	USB1.1&2.0 /I ² C		Prod
IC1114-F48LQ	USB1.1 SM/xD Card Reader		V					32KB Embed Flash	USB1.1&2.0 /I ² C		Prod

Notes:

1. S = Samples 2. Prod = Production 3. In USB1.1 products, Embedded flash & Mask ROM version are not pin to pin compatible.

ICSI LOGIC (CONT'D)

USB2.0 Flash Card Reader Family

Part	Function	CF	SM/xD/ NAND/ MLC	SD/MMC	MMC4.0	MS/MS-Duo MS-Pro	MP3	Code Storage	ISP	Other Embed Functions	Status (1,2)
IC1210-F128LQ(G)	USB2.0 Card Reader	V	V	V	4bitbus	V	V	32KB Embed Flash	USB1.1&2.0 /I ² C	Power switch; Resistors	Prod
IC1230-F128LQ(G)	USB2.0 Card Reader	V	V	V	8bitbus	V	V	32KB Mask ROM	USB1.1&2.0 /I ² C	Power switch; Resistors	Prod
IC1210-M128LQ(G)	USB2.0 Card Reader	V	V	V	4bitbus	V	V	32KB Embed Flash	USB1.1&2.0 /I ² C	Power switch; Resistors	Prod
IC1230-M128LQ(G)	USB2.0 Card Reader	V	V	V	8bitbus	V	V	32KB Mask ROM	USB1.1&2.0 /I ² C	Power switch; Resistors	S=NOW
IC1213-F64TQ(G)	Bridge			V	4bitbus	V	V	32KB Embed Flash	USB1.1&2.0 /I ² C	Power switch; Resistors	Prod
IC1233-F64TQ(G)	USB2.0 Card Reader			V	8bitbus	V	V	32KB Mask ROM		Power switch; Resistors	Prod
IC1213-M64TQ(G)	USB2.0 Card Reader			V	4bitbus	V	V	32KB Mask ROM		Power switch; Resistors	Prod
IC1233-M64TQ(G)	USB2.0 SM/xD Card Reader			V	8bitbus	V	V	32KB Mask ROM		Power switch; Resistors	S=NOW

IDE Flash Card Reader Family

Part	Function	ATAPI Device	ATAPI Host	USB	SM/xD/ NAND/ MLC	CF/SD /MMC	MS/ MS-Duo/ MS-Pro	MP3	Code Storage	ISP	Other Embed Functions	Status (2)
IC1100B-F128LQ(G)	IDE Card Reader & Bridge	True-IDE Device			V	V	V	V	32KB Embed Flash	ATAPI /I ² C	Regulator; Power Switch; Resistors	Prod

Storage Media Hub Family

Part	Function	ATAPI Device	ATAPI Host	USB	SM/xD/ NAND/ MLC	CF/SD /MMC	MS/ MS-Duo/ MS-Pro	MP3/ LCM Interface	SRAM SDRAM Interface	Code Storage	ISP	Other Embed Functions	Status (1)
IC1269-M208LQ	ATAPI Device/ Host w/CRW/ OTG Bridge	UDMA ATAPI Device	UDMA ATAPI Host	USB 2.0 OTG	V	V	V	V	V	64KB Mask ROM	USB/ ATAPI/ I ² C	Regulator; Power switch; Resistors	S= Q4/05

Notes:

1. S = Samples 2. Prod = Production

ICSI LOGIC (CONT'D)

USB Flash Disk Family

Part Number	USB	Multiple Flash On Board	NAND Flash	Single Die NAND Flash	MLC Flash	Code Storage	Other Embed	Boot Function Functions	Status ⁽²⁾
IC1114-F48LQ	1.1	V	V	V	V	32KB Embed Flash	Power switch; Resistors	ZIP	Prod
IC1114-48LQ	1.1	V	V	V	V	32KB Mask ROM	Power switch; Resistors	FDD, ZIP	Prod

Micro Controller Family

Part No.	Function	Vcc	Embedded Flash ROM K-Byte	RAM Byte	Power saving	Power-down wake-up by interrupt	Security	Speed (MHz)	8 interrupt vector	Low EMI mode	Package (Pin)	Status ⁽²⁾
IC80C32	Micro Controller	4.5V-5.5V		256	Idle/Suspend		V	40			DIP (40) PLCC (44) PQFP (44)	Prod
IC89C51A	Micro Controller	4.5V-5.5V	4	256	Idle/Suspend		V	40			DIP (40) PLCC (44) PQFP (44)	Prod
IC89C52A	Micro Controller	4.5V-5.5V	8	256	Idle/Suspend		V	40			DIP (40) PLCC (44) PQFP (44)	Prod
IC80LV51A	Micro Controller	3.0V-3.6V	4	256	Idle/Suspend		V	24			DIP (40) PLCC (44) PQFP (44)	Prod
IC80LV52A	Micro Controller	3.0V-3.6V	8	256	Idle/Suspend		V	24			DIP (40) PLCC (44) PQFP (44)	Prod
IC89C54	Micro Controller	4.5V-5.5V	16	256	Idle/Suspend		V	40			DIP (40) PLCC (44) PQFP (44)	Prod
IC89C58	Micro Controller	4.5V-5.5V	32	256	Idle/Suspend		V	40			DIP (40) PLCC (44) PQFP (44)	Prod
IC89C64	Micro Controller	4.5V-5.5V	64	256	Idle/Suspend		V	40			DIP (40) PLCC (44) PQFP (44)	Prod
IC89E54	Micro Controller w/ extra function	4.5V-5.5V	16	256 + 512	Idle/Power Down	V	V	40	44-pin pkg only	V	DIP (40) PLCC (44) PQFP (44)	Prod
IC89E58	Micro Controller w/ extra function	4.5V-5.5V	32	256 + 512	Idle/Power Down	V	V	40	44-pin pkg only	V	DIP (40) PLCC (44) PQFP (44)	Prod
IC89E64	Micro Controller w/ extra function	4.5V-5.5V	64	256 + 512	Idle/Power Down	V	V	40	44-pin pkg only	V	DIP (40) PLCC (44) PQFP (44)	Prod

Notes: 1. S = Samples 2. Prod = Production

ORDERING INFORMATION FOR ICSI DEVICES

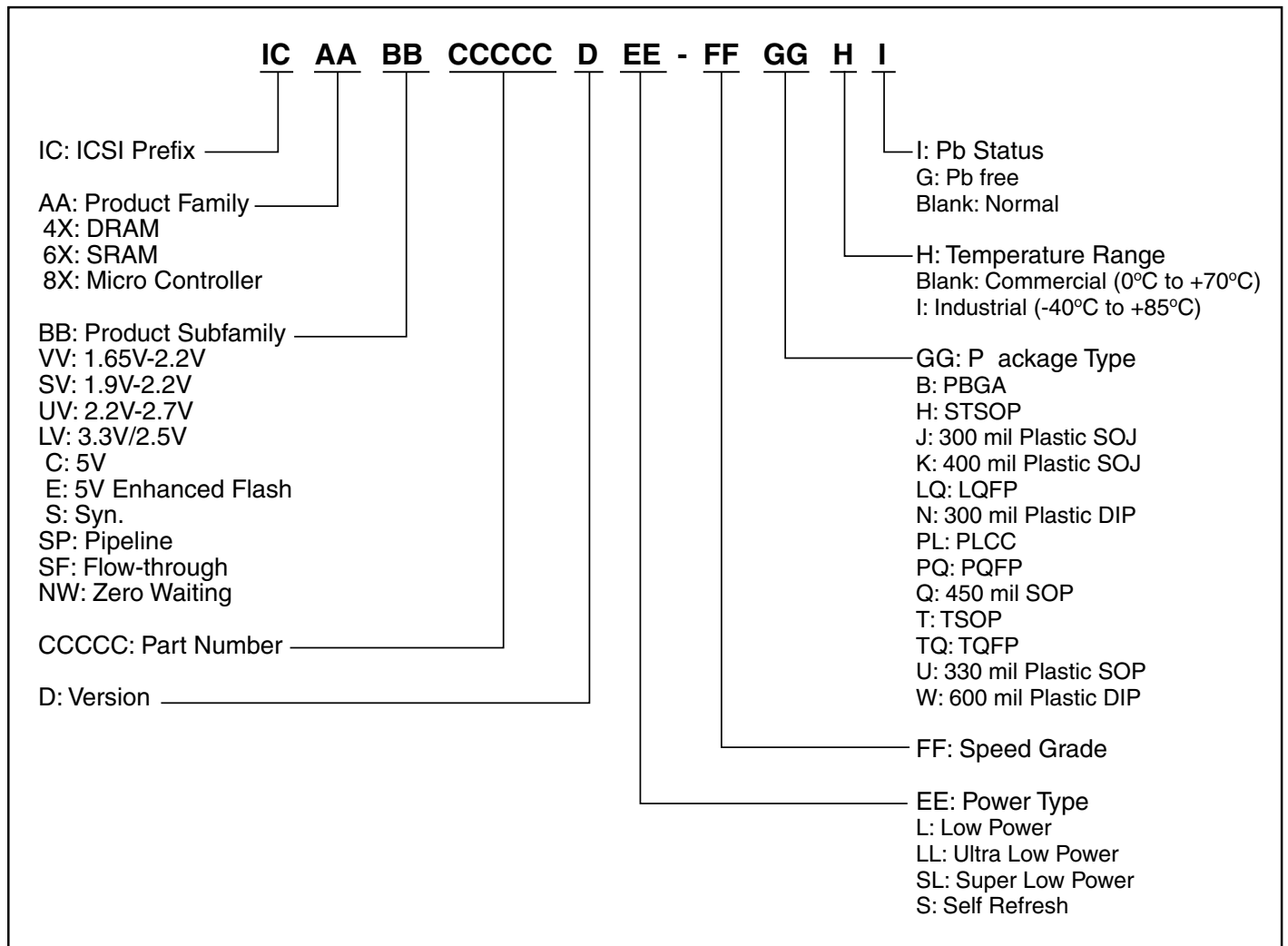

Europe

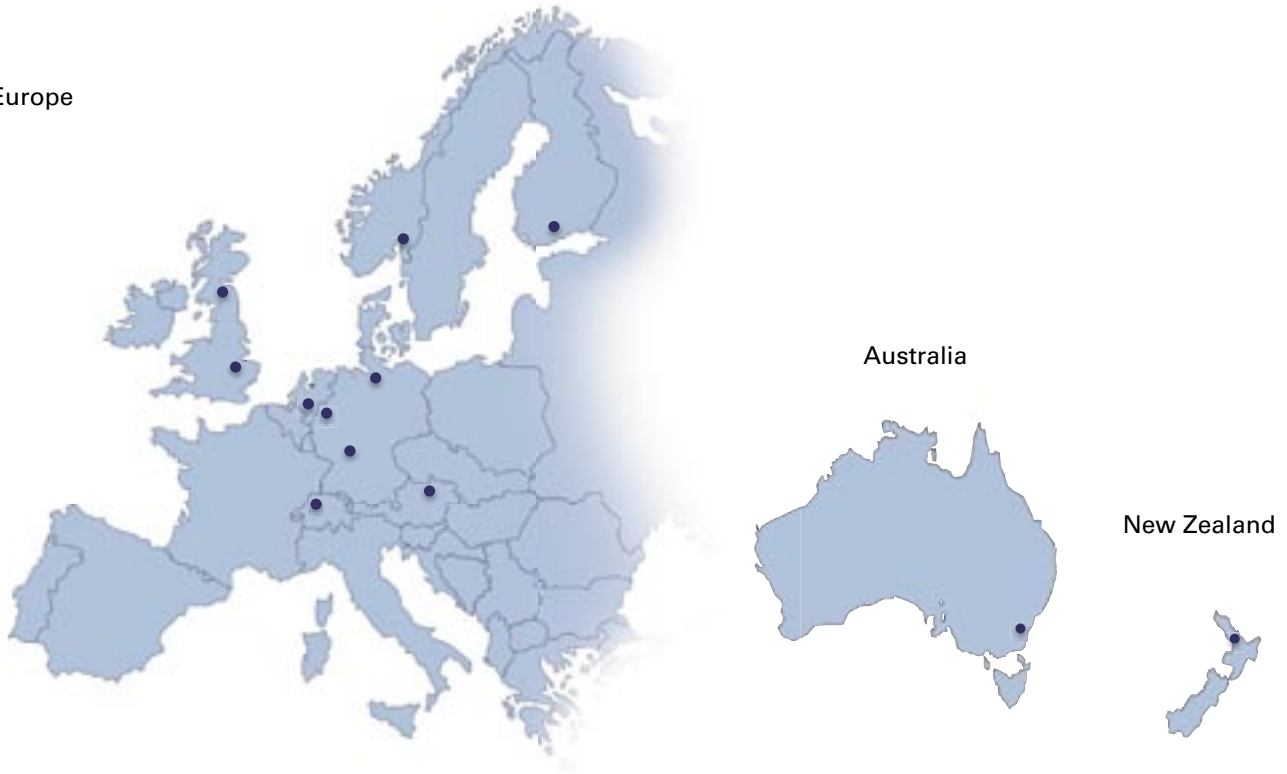

Australia

New Zealand

GLYN GmbH & Co. KG
Head Office
Am Wörtzgarten 8
D-65510 Idstein
Tel. +49-(0)6126-590-222
Fax +49-(0)6126-590-111
Internet: www.glyn.de
e-mail: sales@glyn.de

GLYN GmbH & Co. KG
Office Nettetal
Ringstr. 88
D-41334 Nettetal
Tel. +49-(0)2157-124-222
Fax +49-(0)2157-124-211
Internet: www.glyn.de
e-mail: nettetal@glyn.de

GLYN GmbH & Co. KG
Office Nord
Langenharmer Weg 65h
D-22844 Norderstedt
Tel. +49-(0)40-943615-31
Fax +49-(0)40-943615-30
Internet: www.glyn.de
e-mail: nord@glyn.de

GLYN Austria
Waidhausenstr. 13 Top 9
A-1140 Wien
Tel. +43-(0)1-4190714-0
Fax +43-(0)1-4190714-50
Internet: www.glyn.de
e-mail: austria@glyn.de

GLYN Schweiz
Bachweg 3
CH-8133 Esslingen / Zürich
Tel. +41-(0)44-905-5000
Internet: www.glyn.ch
e-mail: sales@glyn.ch

GLYN Benelux
Kerkhofstraat 21
NL-5554 HG Valkenswaard
Tel. +31-(0)40-2049700
Fax +31-(0)40-2049784
Internet: www.glyn.de
e-mail: benelux@glyn.de

GLYN Finland
Tekniikantie 12
SF-02150 Espoo
Tel. +358-(0)9-2517-3585
Fax: +358-(0)9-2517-3587
mobile +358- 40-772-6585
Internet: www.glyn.de
e-mail: finland@glyn.de

GLYN Norway
Link Electronics AS
Postboks 135
Gramveien 76
N-1800 Askim
Tel. +47(0)-6988-9899
Fax +47(0)-6988-9799
Internet: www.linknordic.com
e-mail: info@linknordic.com

GLYN Ltd. U.K.
3 Woodbrook Crescent
Radford Way
GB-CM12 0EQ Billericay
Tel. +44-(0)1277-634200
Fax +44-(0)1277-631439
Internet: www.glyn.com
e-mail: sales@glyn.com

GLYN Ltd. Australia
Level 2 Suite 1A
802 Pacific Highway
AUS-2072 Gordon NSW
Tel. +61-(0)2-9844-5439
Fax +61-(0)2-9498-1300
Internet: www.glyn.com.au
e-mail: sales@glyn.com.au

GLYN Ltd. U.K.
Northern Office
35 Wansdyke
Lancaster Park
GB-NE61 3RA Morpeth
Northumberland
Tel. +44-(0)1670-514616
Fax +44-(0)1670-516936
Internet: www.glyn.com
e-mail: sales@glyn.com

GLYN Ltd. New Zealand
Unit 5, 18 Airborne Road
NZ-1311 Albany, Auckland
Tel. +64-(0)9-441-9050
Fax +64-(0)9-441-9060
Internet: www.glyn.co.nz
e-mail: sales@glyn.co.nz

GLYN
High-Tech Distribution

© 2005 by GLYN GmbH & Co. KG

Attention!
With this overview we only present a selection of our product portfolio.
With some manufacturers we may have special regulations and/or restrictions
for some European countries.

tüv
CERT
DIN ISO 9001