

# M81706AFP

HIGH VOLTAGE HALF BRIDGE DRIVER

## DESCRIPTION

M81706AFP is high voltage Power MOSFET and IGBT module driver for half bridge applications.

## FEATURES

- FLOATING SUPPLY VOLTAGE . . . 600 V
- OUTPUT CURRENT . . . +120 mA / -250 mA
- HALF BRIDGE DRIVER
- SOP-8

## APPLICATIONS

MOSFET and IGBT module inverter driver for PDP, HID lamp, refrigerator, air-conditioner, washing machine, AC-servomotor and general purpose.

## PIN CONFIGURATION (TOP VIEW)

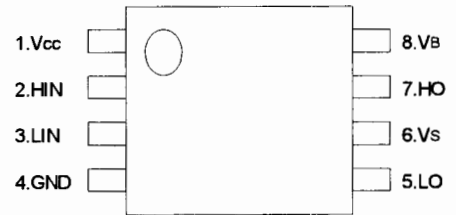

Outline : 8P2S

## BLOCK DIAGRAM

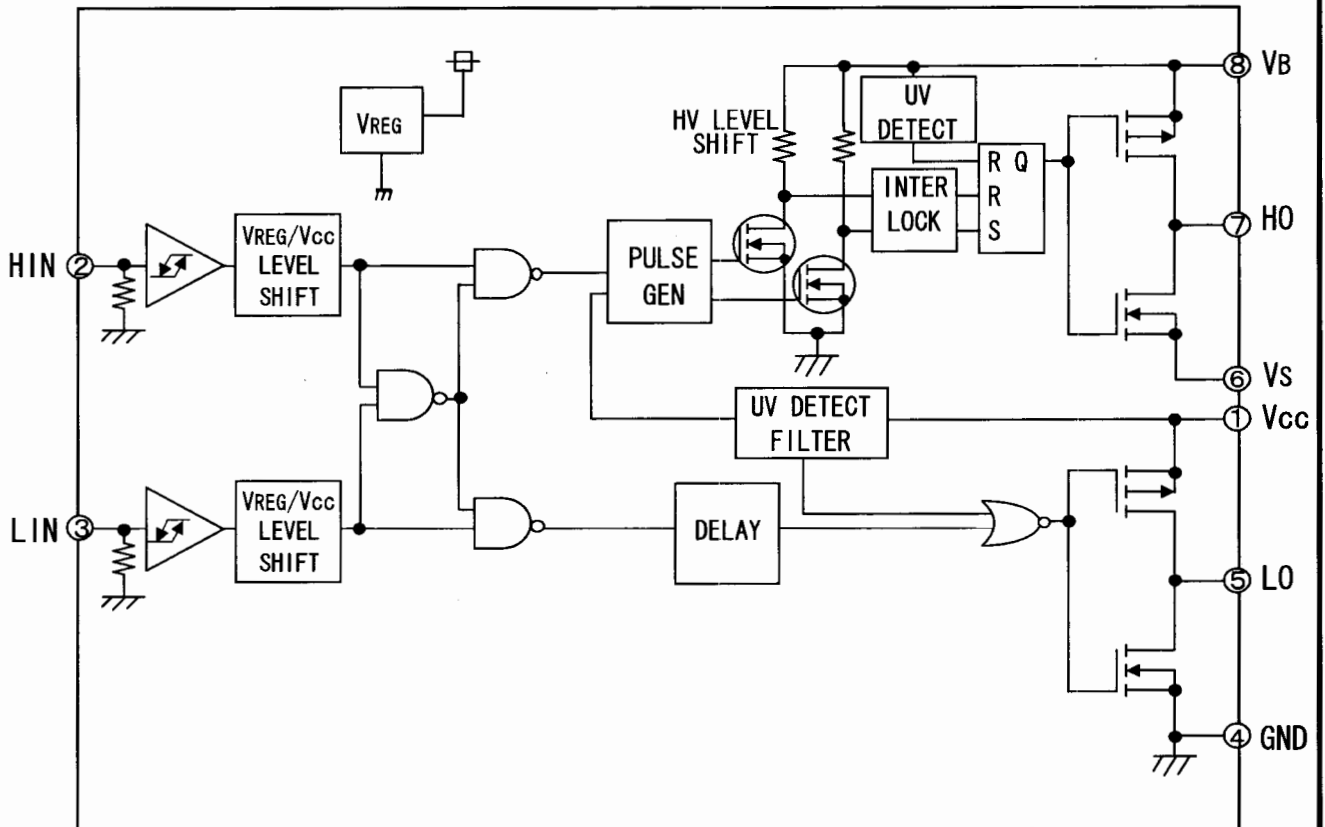

# M81706AFP

## HIGH VOLTAGE HALF BRIDGE DRIVER

### ABSOLUTE MAXIMUM RATINGS

Symbol	Parameter	Test conditions	Ratings	Unit
V <sub>B</sub>	High Side Floating Supply Absolute Voltage		-0.5~624	V
V <sub>S</sub>	High Side Floating Supply Offset Voltage		V <sub>B</sub> -24~V <sub>B</sub> +0.5	V
V <sub>BS</sub>	High Side Floating Supply Voltage	V <sub>BS</sub> =V <sub>B</sub> -V <sub>S</sub>	-0.5~24	V
V <sub>HO</sub>	High Side Output Voltage		V <sub>S</sub> -0.5~V <sub>B</sub> +0.5	V
V <sub>CC</sub>	Low Side Fixed Supply Voltage		-0.5~24	V
V <sub>LO</sub>	Low Side Output Voltage		-0.5~V <sub>CC</sub> +0.5	V
V <sub>IN</sub>	Logic Input Voltage	HIN, LIN	-0.5~V <sub>CC</sub> +0.5	V
P <sub>d</sub>	Package Power Dissipation	T <sub>a</sub> =25°C, On Board	0.6	W
K <sub>θ</sub>	Linear Derating Factor	T <sub>a</sub> >25°C, On Board	6.0	mW/°C
R <sub>th(j-c)</sub>	Junction - Case Thermal Resistance		50	°C/W
T <sub>j</sub>	Junction Temperature		-20~125	°C
T <sub>opr</sub>	Operation Temperature		-20~100	°C
T <sub>stg</sub>	Storage Temperature		-40~125	°C

### RECOMMENDED OPERATING CONDITIONS

Symbol	Parameter	Test conditions	Limits			Unit
			Min.	Typ.	Max.	
V <sub>B</sub>	High Side Floating Supply Absolute Voltage		V <sub>S</sub> +10	—	V <sub>S</sub> +20	V
V <sub>S</sub>	High Side Floating Supply Offset Voltage		0	—	500	V
V <sub>BS</sub>	High Side Floating Supply Voltage	V <sub>BS</sub> =V <sub>B</sub> -V <sub>S</sub>	10	—	20	V
V <sub>HO</sub>	High Side Output Voltage		V <sub>S</sub>	—	V <sub>B</sub>	V
V <sub>CC</sub>	Low Side Fixed Supply Voltage		10	—	20	V
V <sub>LO</sub>	Logic Supply Voltage		0	—	V <sub>CC</sub>	V
V <sub>IN</sub>	Logic Input Voltage	HIN,LIN	0	—	V <sub>CC</sub>	V

### Thermal Derating Factor Characteristic

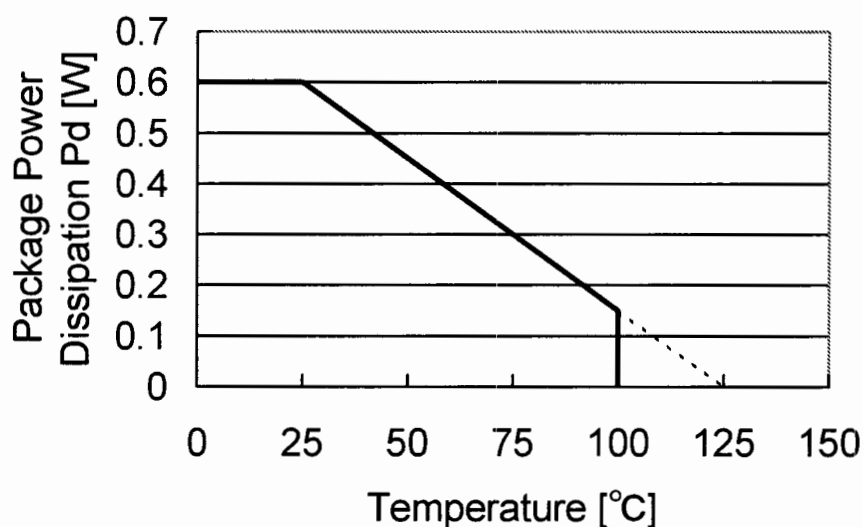

**M81706AFP**

HIGH VOLTAGE HALF BRIDGE DRIVER

**ELECTRICAL CHARACTERISTICS (Ta = 25°C, Vcc=Vbs(=Vb-Vs)=15V, unless otherwise specified)**

Symbol	Parameter	Test conditions	Limits			Unit
			Min.	Typ. *	Max.	
I <sub>FS</sub>	Floating Supply Leakage Current	V <sub>B</sub> =V <sub>S</sub> =600V	—	—	1.0	μA
I <sub>BS</sub>	V <sub>BS</sub> standby Current	H <sub>IN</sub> =L <sub>IN</sub> =0V	—	0.2	0.5	mA
I <sub>CC</sub>	V <sub>CC</sub> standby Current	H <sub>IN</sub> =L <sub>IN</sub> =0V	0.2	0.5	1.0	mA
V <sub>OH</sub>	High Level Output Voltage	I <sub>O</sub> =-20mA, L <sub>O</sub> , H <sub>O</sub>	13.6	14.2	—	V
V <sub>OL</sub>	Low Level Output Voltage	I <sub>O</sub> =20mA, L <sub>O</sub> , H <sub>O</sub>	—	0.3	0.6	V
V <sub>IH</sub>	High Level Input Threshold Voltage	H <sub>IN</sub> , L <sub>IN</sub>	2.7	—	—	V
V <sub>IL</sub>	Low Level Input Threshold Voltage	H <sub>IN</sub> , L <sub>IN</sub>	—	—	0.8	V
I <sub>IH</sub>	High Level Input Bias Current	V <sub>IN</sub> =5V	—	5	20	μA
I <sub>IL</sub>	Low Level Input Bias Current	V <sub>IN</sub> =0V	—	—	2	μA
V <sub>BSUVr</sub>	V <sub>BS</sub> Supply UV Reset Voltage		8.0	8.9	9.8	V
V <sub>BSUVt</sub>	V <sub>BS</sub> Supply UV Trip Voltage		7.4	8.2	9.0	V
V <sub>BSUVh</sub>	V <sub>BS</sub> Supply UV Hysteresis Voltage		0.5	0.7	—	V
t <sub>VBSUV</sub>	V <sub>BS</sub> Supply UV Filter Time		—	7.5	—	μs
V <sub>CCUVr</sub>	V <sub>CC</sub> Supply UV Reset Voltage		8.0	8.9	9.8	V
V <sub>CCUVt</sub>	V <sub>CC</sub> Supply UV Trip Voltage		7.4	8.2	9.0	V
V <sub>CCUVh</sub>	V <sub>CC</sub> Supply UV Hysteresis Voltage		0.5	0.7	—	V
t <sub>VCCUV</sub>	V <sub>CC</sub> Supply UV Filter Time		—	7.5	—	μs
I <sub>OH</sub>	Output High Level Short Circuit Pulsed Current	V <sub>O</sub> =0V, V <sub>IN</sub> =5V, PW<10 μs	120	200	—	mA
I <sub>OL</sub>	Output Low Level Short Circuit Pulsed Current	V <sub>O</sub> =15V, V <sub>IN</sub> =0V, PW<10 μs	250	350	—	mA
R <sub>OH</sub>	Output High Level On Resistance	I <sub>O</sub> =-20mA, R <sub>OH</sub> =(V <sub>OH</sub> -V <sub>O</sub> )/I <sub>O</sub>	—	40	70	Ω
R <sub>OL</sub>	Output Low Level On Resistance	I <sub>O</sub> =20mA, R <sub>OL</sub> =V <sub>O</sub> /I <sub>O</sub>	—	15	30	Ω
t <sub>dLH</sub> (H <sub>O</sub> )	High Side Turn-On Propagation Delay	C <sub>L</sub> =1000pF between H <sub>O</sub> -V <sub>S</sub>	—	120	240	ns
t <sub>dHL</sub> (H <sub>O</sub> )	High Side Turn-Off Propagation Delay	C <sub>L</sub> =1000pF between H <sub>O</sub> -V <sub>S</sub>	—	170	280	ns
t <sub>rH</sub>	High Side Turn-On Rise Time	C <sub>L</sub> =1000pF between H <sub>O</sub> -V <sub>S</sub>	—	130	220	ns
t <sub>fH</sub>	High Side Turn-Off Fall Time	C <sub>L</sub> =1000pF between H <sub>O</sub> -V <sub>S</sub>	—	50	80	ns
t <sub>dLH</sub> (L <sub>O</sub> )	Low Side Turn-On Propagation Delay	C <sub>L</sub> =1000pF between L <sub>O</sub> -GND	—	120	240	ns
t <sub>dHL</sub> (L <sub>O</sub> )	Low Side Turn-Off Propagation Delay	C <sub>L</sub> =1000pF between L <sub>O</sub> -GND	—	170	280	ns
t <sub>rL</sub>	Low Side Turn-On Rise Time	C <sub>L</sub> =1000pF between L <sub>O</sub> -GND	—	130	220	ns
t <sub>fL</sub>	Low Side Turn-Off Fall Time	C <sub>L</sub> =1000pF between L <sub>O</sub> -GND	—	50	80	ns
Δt <sub>dLH</sub>	Delay Matching, High Side and Low Side Turn-On	t <sub>dLH</sub> (H <sub>O</sub> )-t <sub>dLH</sub> (L <sub>O</sub> )	—	0	30	ns
Δt <sub>dHL</sub>	Delay Matching, High Side and Low Side Turn-Off	t <sub>dHL</sub> (H <sub>O</sub> )-t <sub>dHL</sub> (L <sub>O</sub> )	—	0	30	ns

\*Typ. is not specified

# M81706AFP

HIGH VOLTAGE HALF BRIDGE DRIVER

**FUNCTION TABLE** (X : HorL)

HIN	LIN	Vbs UV	Vcc UV	HO	LO	Behavioral State
L	L	H	H	L	L	LO = HO = Low
L	H	H	H	L	H	LO = High
H	L	H	H	H	L	HO = High
H	H	H	H	L	L	LO = HO = Low
X	L	L	H	L	L	HO = Low, Vbs UV tripped
X	H	L	H	L	H	LO = High, Vbs UV tripped
L	X	H	L	L	L	LO = Low, Vcc UV tripped
H	X	H	L	L	L	HO = LO = Low, Vcc UV tripped

Note: "L" state of Vbs UV, Vcc UV means that UV trip voltage.

In the case of both input signals (HIN and LIN) are "H", output signals (HO and LO) become "L".

## TIMING DIAGRAM

### 1. Input/Output Timing Diagram

HIGH ACTIVE(When input signal(HIN or LIN) is "H", then output signal (HO or LO) is "H".)

In the case of both input signals (HIN and LIN) are "H", output signals (HO and LO) become "L".

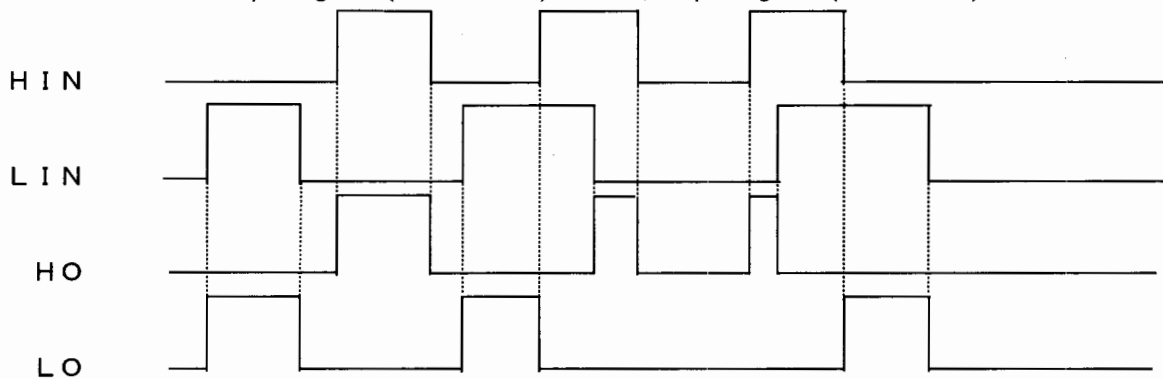

# M81706AFP

## HIGH VOLTAGE HALF BRIDGE DRIVER

### 2. Vcc(VBs) Supply Under Voltage Lockout Timing Diagram

When Vcc Supply Voltage keeps lower UV Trip Voltage( $V_{CCUVt} = V_{CCUVR} - V_{CCUVh}$ ) for Vcc Supply UV Filter Time, output signal becomes "L". And then, when Vcc Supply Voltage is higher than UV Reset Voltage, output signal LO becomes "H".

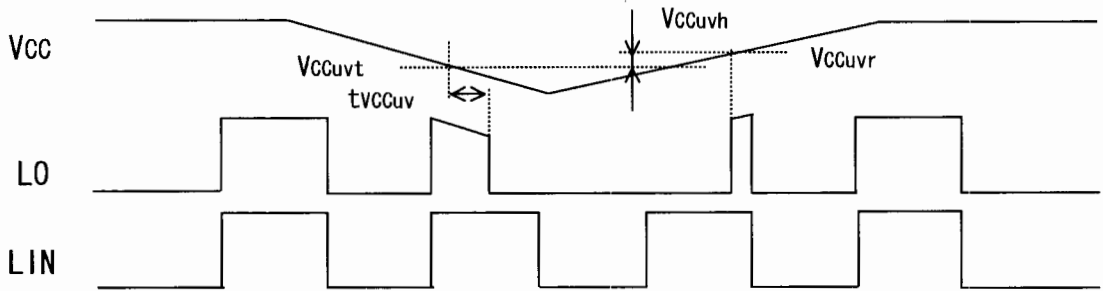

When Vcc Supply Voltage keeps lower UV Trip Voltage( $V_{CCUVt} = V_{CCUVR} - V_{CCUVh}$ ) for Vcc Supply UV Filter Time, output signal becomes "L". And then, when Vcc Supply Voltage is higher than UV Reset Voltage, input signal (LIN) is L; output signal HO becomes "H".

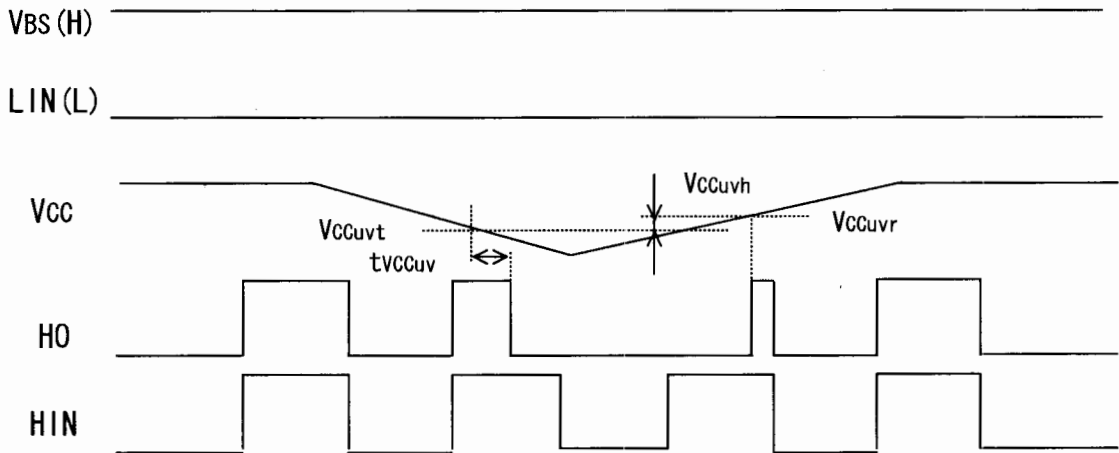

When Vbs Supply Voltage keeps lower UV Trip Voltage ( $V_{BSUVt} = V_{BSUVR} - V_{BSUVh}$ ) for Vbs Supply UV Filter Time, output signal becomes "L". And then, Vbs Supply Voltage is higher than UV Reset Voltage, output signal HO keeps "L" until next input signal HIN is "H".

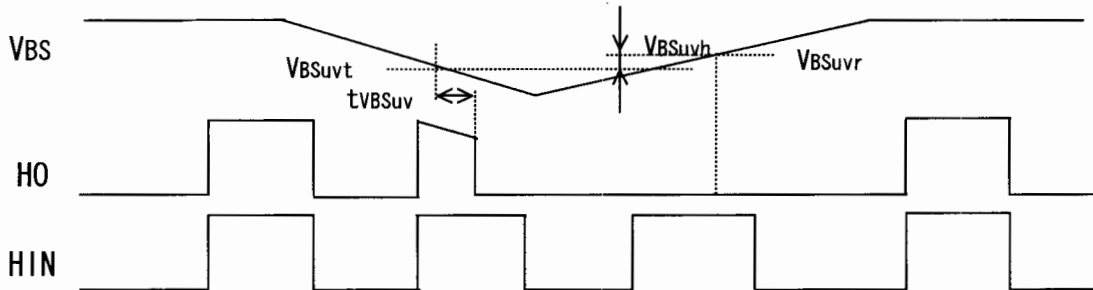

# M81706AFP

HIGH VOLTAGE HALF BRIDGE DRIVER

### 3. Allowable supply voltage transient

It is recommended that supplying Vcc firstly and supplying Vbs secondly. In the case of shutting off supply voltage, shutting off Vbs firstly and shutting off Vcc secondly. At the time of starting Vcc and Vbs, power supply should be increased slowly. If it is increased rapidly, output signal (HO or LO) may be "H".

### Consideration

As for this product, the terminal of low voltage part and high-voltage part is very clear (The Fifth: LO, The Sixth: Vs). Therefore, pin insulation space distance should be taken enough.

### PACKAGE OUTLINE

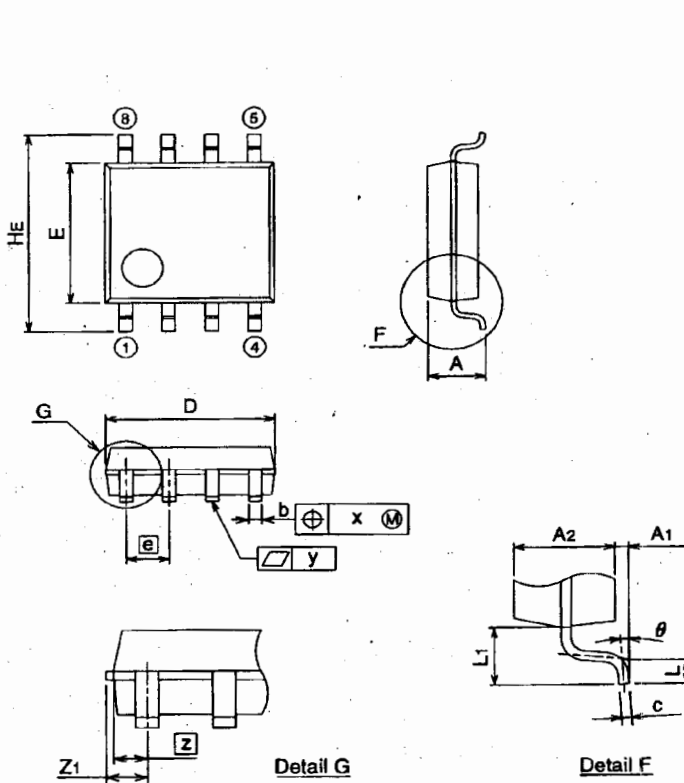

Recommended Mount Pad

Symbol	Dimension in Millimeters		
	Min	Nom	Max
A	-	-	1.9
A1	0.05	-	-
A2	-	1.5	-
b	0.35	0.4	0.5
c	0.13	0.15	0.2
D	4.8	5.0	5.2
E	4.2	4.4	4.6
e	-	1.27	-
HE	5.9	6.2	6.5
L	0.2	0.4	0.6
L1	-	0.9	-
Z	-	0.595	-
Z1	-	-	0.745
x	-	-	0.25
y	-	-	0.1
θ	0°	-	10°
b2	-	0.76	-
e1	-	5.72	-
l2	1.27	-	-