

BATTERY PROTECTION IC FOR 2-SERIAL TO 4-SERIAL-CELL PACK (SECONDARY PROTECTION)

S-8264A/B Series

The S-8264A/B Series is used for secondary protection of lithium-ion rechargeable batteries, and incorporates a high-accuracy voltage detection circuit and a delay circuit. Short-circuits between cells accommodate series connection of two to four cells.

■ Features

- (1) High-accuracy voltage detection circuit for each cell
 - Overcharge detection voltage n (n = 1 to 4)
4.30 V to 4.80 V (in 50 mV steps) Accuracy : ± 25 mV (+25°C), Accuracy : ± 30 mV (–5°C to +55°C)
 - Overcharge hysteresis voltage n (n = 1 to 4)
–0.52 \pm 0.21 V, –0.39 \pm 0.16 V, –0.26 \pm 0.11 V, –0.13 \pm 0.06 V, None
- (2) Delay times for overcharge detection can be set by an internal circuit only (external capacitors are unnecessary)
- (3) Output control function via CTL pin (S-8264A Series)
- (4) Output latch function after overcharge detection (S-8264B Series)
- (5) Output form and logic CMOS output active “H”
- (6) High withstand voltage devices Absolute maximum rating : 26 V
- (7) Wide operating voltage range 3.6 V to 24 V
- (8) Wide operating temperature range –40°C to +85°C
- (9) Low current consumption
 - At 3.5 V for each cell 5.0 μ A max. (+25°C)
 - At 2.3 V for each cell 4.0 μ A max. (+25°C)
- (10) Lead-free products

■ Application

- Lithium-ion rechargeable battery packs (for secondary protection)

■ Packages

Package Name	Drawing Code			
	Package	Tape	Reel	Land
SNT-8A	PH008-A	PH008-A	PH008-A	PH008-A
8-Pin TSSOP	FT008-A	FT008-E	FT008-E	—

■ Block Diagrams

(1) S-8264A Series

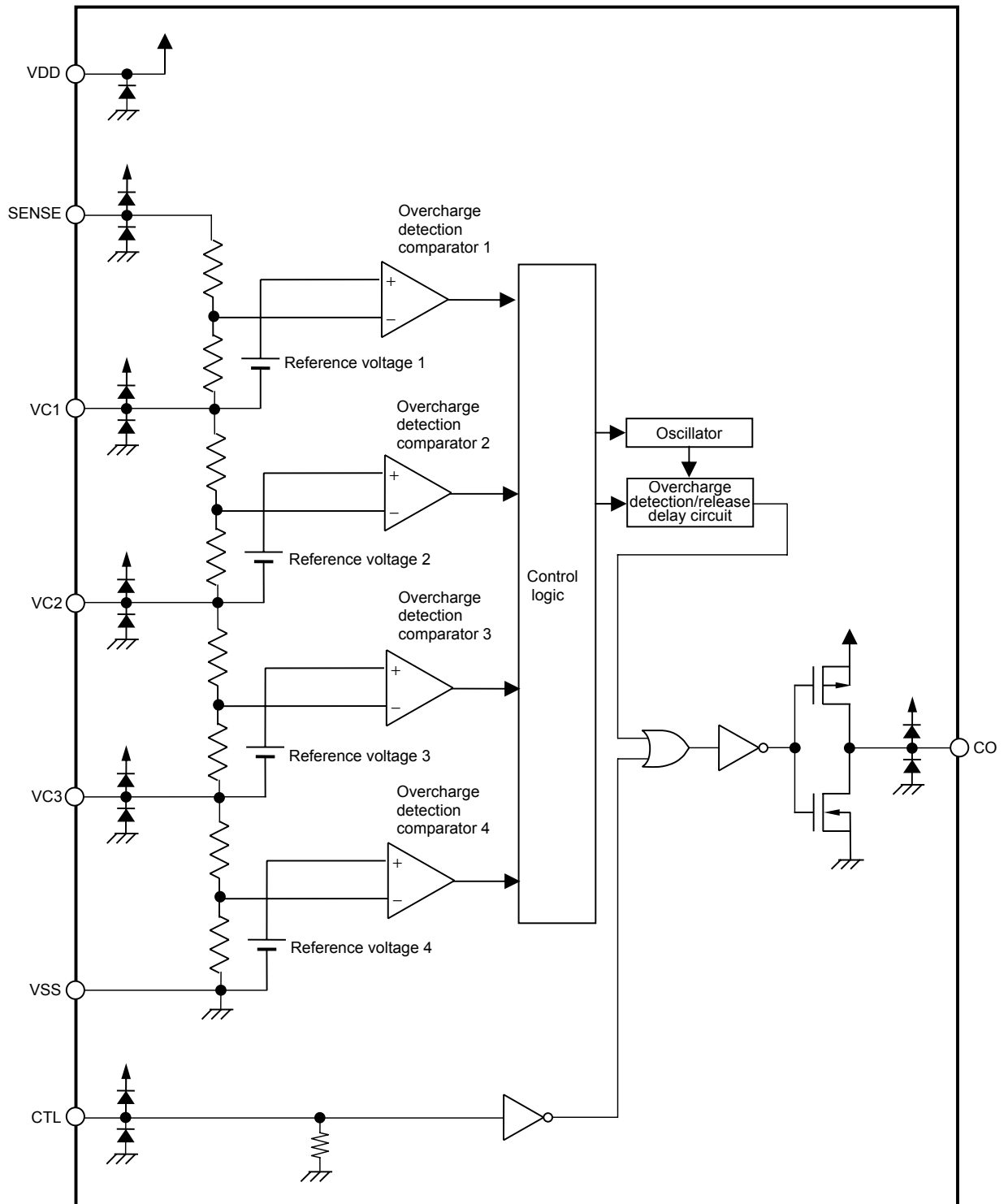

Remark The diodes in the figure are parasitic diodes.

Figure 1

(2) S-8264B Series

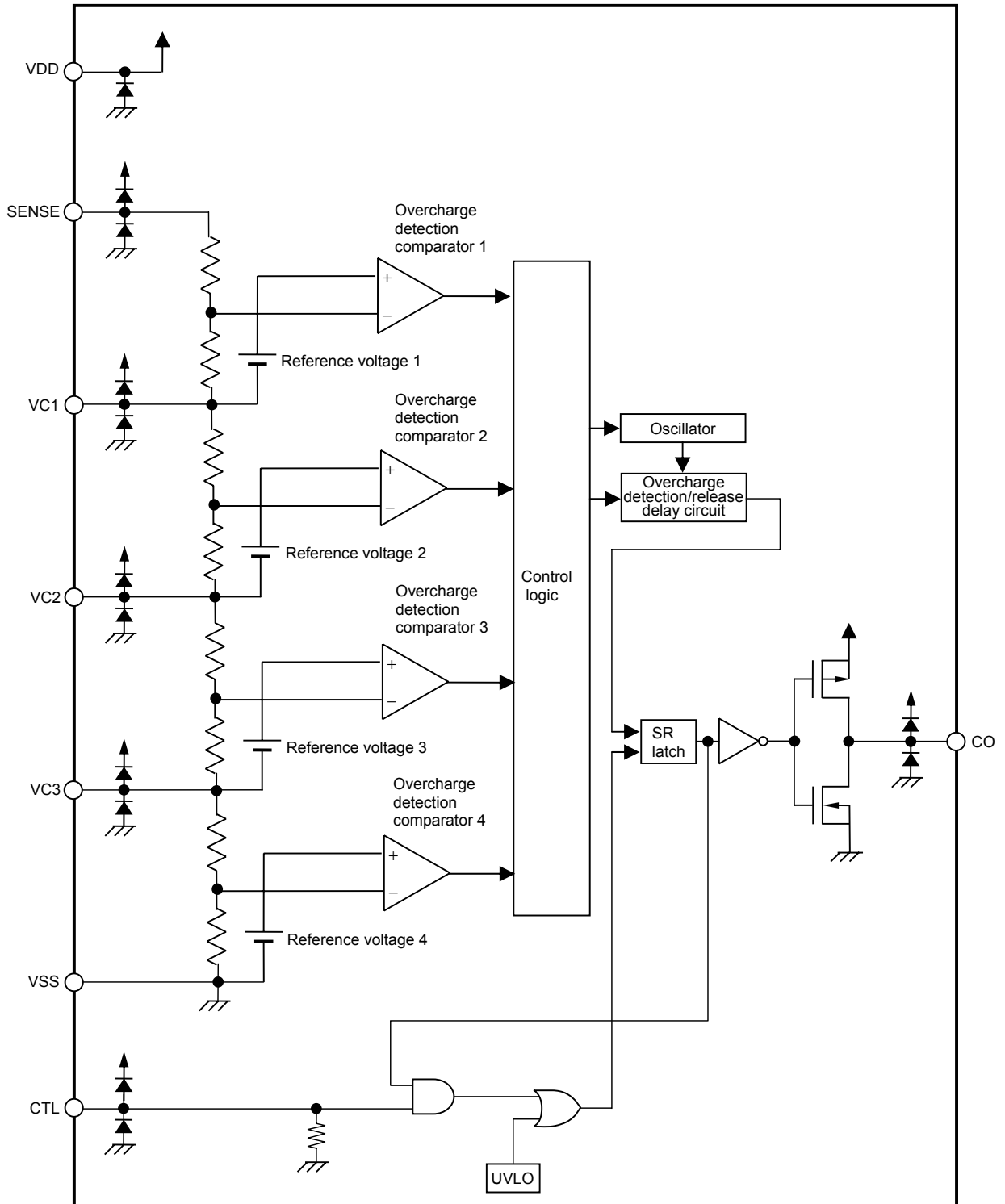

Remark The diodes in the figure are parasitic diodes.

Figure 2

■ **Product Name Structure**

1. Product Name

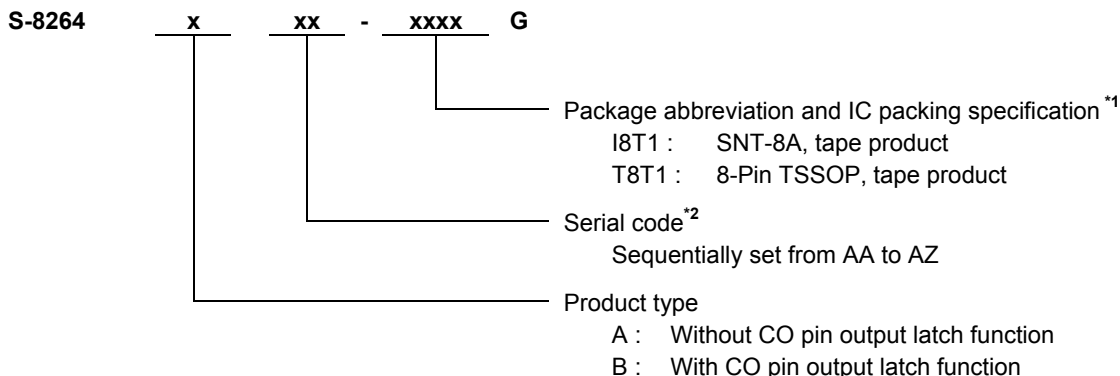

*1. Refer to the tape specifications at the end of this book.

*2. Refer to "2. Product Name List".

2. Product Name List

(1) S-8264A Series

Table 1 SNT-8A

Product Name / Item	Overcharge Detection Voltage [V _{CU}]	Overcharge Hysteresis Voltage [V _{HC}]	Overcharge Detection Delay Time [t _{CU}]	Output Form
S-8264AAA-I8T1G	4.45 ±0.025 V	-0.39 ±0.16 V	4.0 ±0.8 s	CMOS output active "H"
S-8264AAB-I8T1G	4.35 ±0.025 V	-0.39 ±0.16 V	4.0 ±0.8 s	CMOS output active "H"
S-8264AAC-I8T1G	4.50 ±0.025 V	-0.39 ±0.16 V	4.0 ±0.8 s	CMOS output active "H"
S-8264AAD-I8T1G	4.35 ±0.025 V	-0.39 ±0.16 V	2.0 ±0.4 s	CMOS output active "H"
S-8264AAE-I8T1G	4.30 ±0.025 V	-0.39 ±0.16 V	4.0 ±0.8 s	CMOS output active "H"
S-8264AAF-I8T1G	4.45 ±0.025 V	-0.39 ±0.16 V	2.0 ±0.4 s	CMOS output active "H"
S-8264AAG-I8T1G	4.30 ±0.025 V	-0.39 ±0.16 V	2.0 ±0.4 s	CMOS output active "H"
S-8264AAH-I8T1G	4.40 ±0.025 V	-0.39 ±0.16 V	4.0 ±0.8 s	CMOS output active "H"
S-8264AAI-I8T1G	4.40 ±0.025 V	-0.39 ±0.16 V	2.0 ±0.4 s	CMOS output active "H"
S-8264AAJ-I8T1G	4.45 ±0.025 V	-0.39 ±0.16 V	5.65 ±1.15 s	CMOS output active "H"
S-8264AAK-I8T1G	4.35 ±0.025 V	-0.39 ±0.16 V	5.65 ±1.15 s	CMOS output active "H"

Remark Please contact our sales department for the products with detection voltage value other than those specified above.

Table 2 8-Pin TSSOP

Product Name / Item	Overcharge Detection Voltage [V _{CU}]	Overcharge Hysteresis Voltage [V _{HC}]	Overcharge Detection Delay Time [t _{CU}]	Output Form
S-8264AAA-T8T1G	4.45 ±0.025 V	-0.39 ±0.16 V	4.0 ±0.8 s	CMOS output active "H"
S-8264AAB-T8T1G	4.35 ±0.025 V	-0.39 ±0.16 V	4.0 ±0.8 s	CMOS output active "H"

Remark Please contact our sales department for the products with detection voltage value other than those specified above.

(2) S-8264B Series

Table 3 SNT-8A

Product Name / Item	Overcharge Detection Voltage [V _{CU}]	Overcharge Hysteresis Voltage [V _{HC}]	Overcharge Detection Delay Time [t _{CU}]	Output Form
S-8264BAA-I8T1G	4.45 ±0.025 V	-0.39 ±0.16 V	4.0 ±0.8 s	CMOS output active "H"
S-8264BAB-I8T1G	4.35 ±0.025 V	-0.39 ±0.16 V	4.0 ±0.8 s	CMOS output active "H"

Remark Please contact our sales department for the products with detection voltage value other than those specified above.

■ Pin Configurations

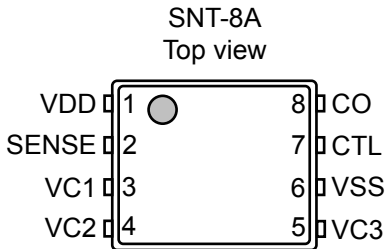

Figure 3

Table 4

Pin No.	Symbol	Description
1	VDD	Positive power input pin
2	SENSE	Positive voltage connection pin of battery 1
3	VC1	Negative voltage connection pin of battery 1 Positive voltage connection pin of battery 2
4	VC2	Negative voltage connection pin of battery 2 Positive voltage connection pin of battery 3
5	VC3	Negative voltage connection pin of battery 3 Positive voltage connection pin of battery 4
6	VSS	Negative power input pin Negative voltage connection pin of battery 4
7	CTL	CO output control pin (S-8264A Series) Overcharge detection latch reset pin (S-8264B Series)
8	CO	FET gate connection pin for charge

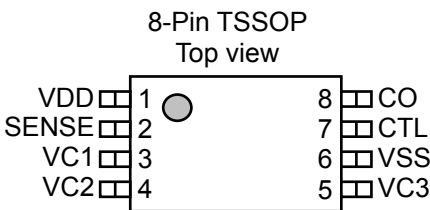

Figure 4

Table 5

Pin No.	Symbol	Description
1	VDD	Positive power input pin
2	SENSE	Positive voltage connection pin of battery 1
3	VC1	Negative voltage connection pin of battery 1 Positive voltage connection pin of battery 2
4	VC2	Negative voltage connection pin of battery 2 Positive voltage connection pin of battery 3
5	VC3	Negative voltage connection pin of battery 3 Positive voltage connection pin of battery 4
6	VSS	Negative power input pin Negative voltage connection pin of battery 4
7	CTL	CO output control pin (S-8264A Series) Overcharge detection latch reset pin (S-8264B Series)
8	CO	FET gate connection pin for charge

■ **Absolute Maximum Ratings**

Table 6

(Ta = 25°C unless otherwise specified)

Item	Symbol	Applied Pins	Rating	Unit
Input voltage between VDD and VSS	V _{DS}	VDD	V _{SS} - 0.3 to V _{SS} + 26	V
Input pin voltage	V _{IN}	SENSE, VC1, VC2, VC3, CTL	V _{SS} - 0.3 to V _{DD} + 0.3	V
CO output pin voltage	V _{CO}	CO	V _{SS} - 0.3 to V _{DD} + 0.3	V
Power dissipation	SNT-8A	—	450*1	mW
	8-Pin TSSOP		700*1	mW
Operation ambient temperature	T _{opr}	—	-40 to +85	°C
Storage temperature	T _{stg}	—	-40 to +125	°C

*1. When mounted on board

[Mounted board]

- (1) Board size : 114.3 mm × 76.2 mm × t1.6 mm
- (2) Name : JEDEC STANDARD51-7

Caution The absolute maximum ratings are rated values exceeding which the product could suffer physical damage. These values must therefore not be exceeded under any conditions.

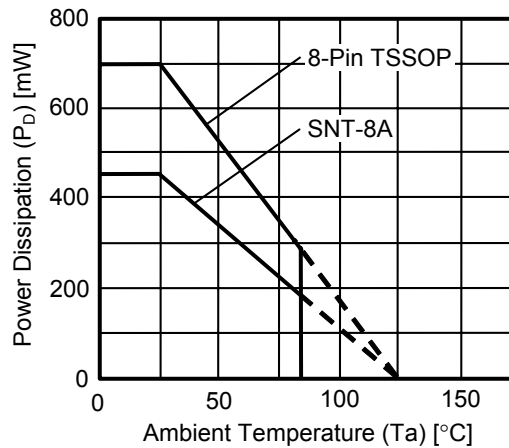

Figure 5 Power Dissipation of Package (When Mounted on Board)

■ Electrical Characteristics

1. Except Detection Delay Time

Table 7

(Ta = 25°C unless otherwise specified)

Item	Symbol	Conditions	Min.	Typ.	Max.	Unit	Test Condition	Test Circuit
DETECTION VOLTAGE								
Overcharge detection voltage n (n = 1, 2, 3, 4)	V _{CU_n}	4.30 V to 4.80 V, adjustable, Ta = 25°C	V _{CU_n} - 0.025	V _{CU_n}	V _{CU_n} + 0.025	V	1	1
		4.30 V to 4.80 V, adjustable, Ta = -5°C to +55°C*1	V _{CU_n} - 0.030	V _{CU_n}	V _{CU_n} + 0.030	V	1	1
Overcharge hysteresis voltage n ² (n = 1, 2, 3, 4)	V _{HC_n}	—	V _{HC_n} - 0.21	-0.52	V _{HC_n} + 0.21	V	1	1
INPUT VOLTAGE								
Operating voltage between VDD and VSS	V _{DSOP}	—	3.6	—	24	V	—	—
CTL input "H" voltage	V _{CTLH}	—	V _{DD} × 0.95	—	—	V	6	2
CTL input "L" voltage	V _{CTLL}	—	—	—	V _{DD} × 0.4	V	6	2
INPUT CURRENT								
Current consumption during operation	I _{OPE}	V1 = V2 = V3 = V4 = 3.5 V	—	2.5	5.0	μA	7	4
Current consumption during overdischarge	I _{OPE_D}	V1 = V2 = V3 = V4 = 2.3 V	—	2.0	4.0	μA	7	4
SENSE pin current	I _{SENSE}	V1 = V2 = V3 = V4 = 3.5 V	—	1.5	3.2	μA	8	5
VC1 pin current	I _{VC1}	V1 = V2 = V3 = V4 = 3.5 V	-0.3	0	0.3	μA	8	5
VC2 pin current	I _{VC2}	V1 = V2 = V3 = V4 = 3.5 V	-0.3	0	0.3	μA	8	5
VC3 pin current	I _{VC3}	V1 = V2 = V3 = V4 = 3.5 V	-0.3	0	0.3	μA	8	5
CTL pin "H" current	I _{CTLH}	V1 = V2 = V3 = V4 = 3.5 V, V _{CTL} = V _{DD}	1.1	1.5	1.8	μA	8	5
CTL pin "L" current	I _{CTLL}	V1 = V2 = V3 = V4 = 3.5 V, V _{CTL} = 0 V	-0.15	—	—	μA	8	5
OUTPUT CURRENT								
CO pin sink current	I _{COL}	V _{COP} = V _{SS} + 0.5 V	0.4	—	—	mA	9	6
CO pin source current	I _{COH}	V _{COP} = V _{DD} - 0.5 V	20	—	—	μA	9	6

*1. Since products are not screened at high and low temperature, the specification for this temperature range is guaranteed by design, not tested in production.

*2. -0.39 ± 0.16 V, -0.26 ± 0.11 V, -0.13 ± 0.06 V, or none, except for -0.52 V hysteresis product circuits. The overcharge release voltage is the total of the overcharge detection voltage (V_{CU_n}) and the overcharge hysteresis voltage (V_{HC_n}).

2. Detection Delay Time

(1) S-8264AAA, S-8264AAB, S-8264AAC, S-8264AAE, S-8264AAH, S-8264BAA, S-8264BAB

Table 8

(Ta = 25°C unless otherwise specified)

Item	Symbol	Conditions	Min.	Typ.	Max.	Unit	Test Condition	Test Circuit
DELAY TIME								
Overcharge detection delay time	t _{CU}	—	3.2	4.0	4.8	s	2	1
Overcharge timer reset delay time	t _{TR}	—	6	12	20	ms	3	1
Overcharge release delay time	t _{CL}	—	51	64	77	ms	2	1
CTL pin response time	t _{CTL}	—	—	—	2.5	ms	4	2
Transition time to Test mode	t _{TST}	V1 = V2 = V3 = V4 = 3.5 V, V _{DD} ≥ V _{SENSE} + 8.5 V	—	—	80	ms	5	3

(2) S-8264AAD, S-8264AAF, S-8264AAG, S-8264AAI

Table 9

(Ta = 25°C unless otherwise specified)

Item	Symbol	Conditions	Min.	Typ.	Max.	Unit	Test Condition	Test Circuit
DELAY TIME								
Overcharge detection delay time	t _{CU}	—	1.6	2.0	2.4	s	2	1
Overcharge timer reset delay time	t _{TR}	—	6	12	20	ms	3	1
Overcharge release delay time	t _{CL}	—	1.6	2.0	3.0	ms	2	1
CTL pin response time	t _{CTL}	—	—	—	2.5	ms	4	2
Transition time to Test mode	t _{TST}	V1 = V2 = V3 = V4 = 3.5 V, V _{DD} ≥ V _{SENSE} + 8.5 V	—	—	80	ms	5	3

(3) S-8264AAJ, S-8264AAK

Table 10

(Ta = 25°C unless otherwise specified)

Item	Symbol	Conditions	Min.	Typ.	Max.	Unit	Test Condition	Test Circuit
DELAY TIME								
Overcharge detection delay time	t _{CU}	—	4.5	5.65	6.8	s	2	1
Overcharge timer reset delay time	t _{TR}	—	8	17	28	ms	3	1
Overcharge release delay time	t _{CL}	—	70	88	110	ms	2	1
CTL pin response time	t _{CTL}	—	—	—	2.5	ms	4	2
Transition time to Test mode	t _{TST}	V1 = V2 = V3 = V4 = 3.5 V, V _{DD} ≥ V _{SENSE} + 8.5 V	—	—	80	ms	5	3

■ Test Circuits

(1) Test Condition 1, Test Circuit 1

Set V1, V2, V3, and V4 to 3.5 V. Overcharge detection voltage 1 (V_{CU1}) is the V1 voltage when CO is “H” after the voltage of V1 has been gradually increased. The overcharge hysteresis voltage (V_{HC1}) is the difference between V1 and V_{CU1} when CO is “L” after the voltage of V1 has been gradually decreased.

Overcharge detection voltage V_{CU_n} ($n = 2$ to 4) and overcharge hysteresis V_{HC_n} ($n = 2$ to 4) can be determined in the same way as when $n = 1$.

(2) Test Condition 2, Test Circuit 1

Set V1, V2, V3, and V4 to 3.5 V and in a moment of time (within 10 μ s) increase V1 up to 5.0 V. The overcharge detection delay time (t_{CU}) is the period from when V1 reached 5.0 V to when CO becomes “H”. After that, in a moment of time (within 10 μ s) decrease V1 down to 3.5 V. The overcharge release delay time (t_{CL}) is the period from when V1 has reached 3.5 V to when CO becomes “L”.

(3) Test Condition 3, Test Circuit 1

Set V1, V2, V3, and V4 to 3.5 V and in a moment of time (within 10 μ s) increase V1 up to 5.0 V. This is defined as the first rise. Within $t_{CU} - 20$ ms after the first rise, in a moment of time (within 10 μ s) decrease V1 down to 3.5 V and then in a moment of time (within 10 μ s) restore up to 5.0 V. This is defined as the second rise. When the period from when V1 was fallen to the second rise is short, CO becomes “H” after t_{CU} has elapsed since the first rise. If the period from when V1 falls to the second rise is gradually made longer, CO becomes “H” when t_{CU} has elapsed since the second rise. The overcharge timer reset delay time (t_{TR}) is the period from V1 fall till the second rise at that time.

(4) Test Condition 4, Test Circuit 2

In the S-8264A Series, set V1, V2, V3, and V4 to 3.5 V and V5 to 14 V. The CTL pin response time (t_{CTL}) is the period from when V5 reaches 0 V after V5 is in a moment of time (within 10 μ s) decreased down to 0 V to when CO becomes “H”.

In the S-8264B Series, set V1, V2, V3, and V4 to 3.5 V and V5 to 14 V after an overvoltage is detected and CO becomes “H”. In a moment of time (within 10 μ s) raise V5 from 0 V to 14 V. The CTL pin response time (t_{CTL}) is the period from when V5 becomes 14 V to when CO becomes “L”.

(5) Test Condition 5, Test Circuit 3

After setting V1, V2, V3, and V4 to 3.5 V and V5 to 0 V, in a moment of time (within 10 μ s) increase V5 up to 8.5 V and decrease V5 again down to 0 V. When the period from when V5 was raised to when it has fallen is short, if an overcharge detection operation is performed subsequently, the overcharge detection time is t_{CU} . However, when the period from when V5 is raised to when it is fallen is gradually made longer, the overcharge detection time during the subsequent overcharge detection operation is shorter than t_{CU} . The transition time to test mode (t_{TST}) is the period from when V5 was raised to when it has fallen at that time.

(6) Test Condition 6, Test Circuit 2

Set V1, V2, V3, and V4 to 3.5 V and V5 to 0 V. The CTL input “H” voltage (V_{CTLH}) is the maximum voltage of V5 when CO is “L” after V5 has been gradually increased. Next, set V5 to 14 V. The CTL input “L” voltage ($V_{CTL L}$) is the minimum voltage of V5 when CO is “H” after V5 has been gradually decreased.

(7) Test Condition 7, Test Circuit 4

The current consumption during operation (I_{OPE}) is the total of the currents that flow in the VDD pin and SENSE pin when V1, V2, V3, and V4 are set to 3.5 V.

The current consumption during overdischarge (I_{OPED}) is the total of the currents that flow in the VDD pin and SENSE pin when V1, V2, V3, and V4 are set to 2.3 V.

(8) Test Condition 8, Test Circuit 5

The SENSE pin current (I_{SENSE}) is I1, the VC1 pin current (I_{VC1}) is I2, the VC2 pin current (I_{VC2}) is I3, the VC3 pin current (I_{VC3}) is I4, and the CTL pin “H” current (I_{CTLH}) is I5 when V1, V2, V3, and V4 are set to 3.5 V, and V5 to 14 V.

The CTL pin “L” current ($I_{CTL L}$) is I5 when V1, V2, V3, and V4 are set to 3.5 V and V5 to 0 V.

(9) Test Condition 9, Test Circuit 6

Set SW1 to OFF and SW2 to ON. The CO pin sink current (I_{COL}) is I2 when V1, V2, V3, and V4 are set to 3.5 V and V6 to 0.5 V.

Set SW1 and SW2 to OFF. Set V1 to V5, set V2, V3, and V4 to 3.0 V, and set V5 to 0.5 V. After t_{CU} has elapsed, set SW1 to ON and SW2 to OFF. I1 is the CO pin source current (I_{COH}).

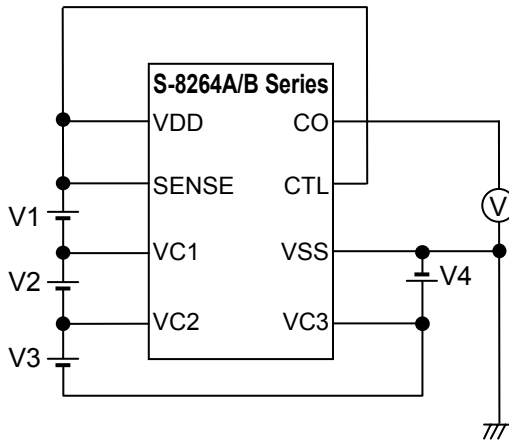

Test Circuit 1

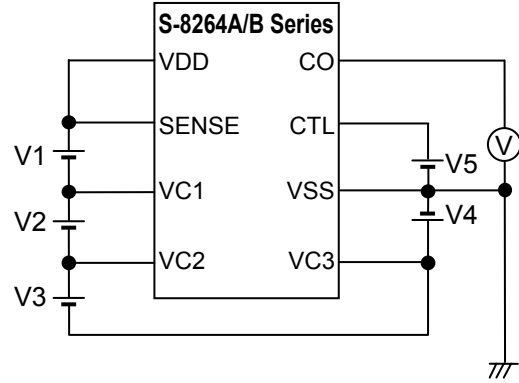

Test Circuit 2

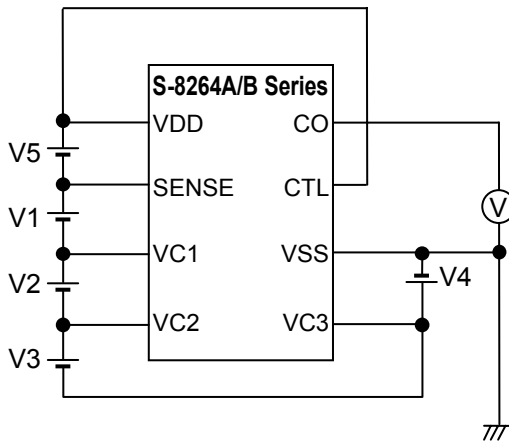

Test Circuit 3

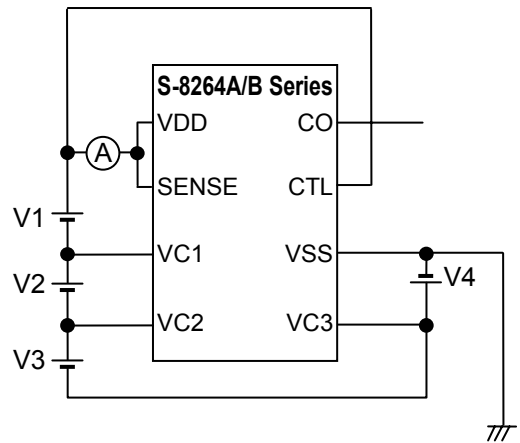

Test Circuit 4

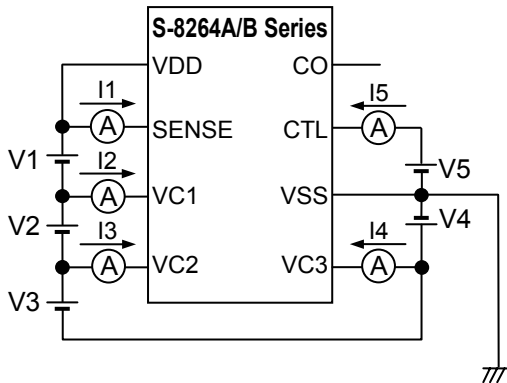

Test Circuit 5

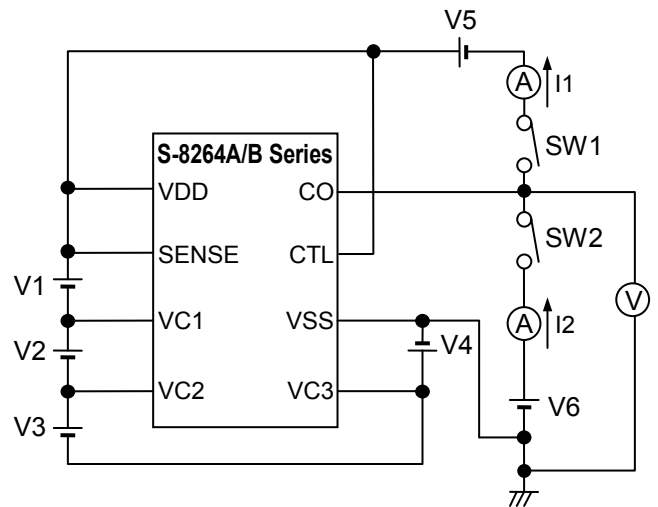

Test Circuit 6

Figure 6

■ Operation

Remark Refer to “■ Battery Protection IC Connection Example”.

1. Overcharge Detection

When the voltage of one of the batteries exceeds the overcharge detection voltage (V_{CU}) during charging under normal conditions and the state is retained for the overcharge detection delay time (t_{CU}) or longer, CO becomes “H”. This state is called overcharge. Attaching FET to the CO pin provides charge control and a second protection.

In the S-8264A Series, if the voltage of all the batteries decreases below the total of the overcharge detection voltage (V_{CU}) and the overcharge hysteresis voltage (V_{HC}) and the state is retained for the overcharge release delay time (t_{CL}) or longer, CO becomes “L”.

In the S-8264B Series, if the voltage of all the batteries decreases below the total of the overcharge detection voltage (V_{CU}) and the overcharge hysteresis voltage (V_{HC}) and the state is retained for the overcharge release delay time (t_{CL}) or longer, the overcharge status is released; however, CO stays at “H”. When the CTL pin is switched from “L” to “H”, CO becomes “L”.

2. Overcharge Timer Reset

When an overcharge release noise that forces the voltage of the battery temporarily below the overcharge detection voltage (V_{CU}) is input during the overcharge detection delay time (t_{CU}) from when V_{CU} is exceeded to when charging is stopped, t_{CU} is continuously counted if the time the overcharge release noise persists is shorter than the overcharge timer reset delay time (t_{TR}). Under the same conditions, if the time the overcharge release noise persists is t_{TR} or longer, counting of t_{CU} is reset once. After that, when V_{CU} has been exceeded, counting t_{CU} resumes.

3. CTL Pin

The S-8264A/B Series has a control pin. The CTL pin is used to control the output voltage of the CO pin.

In the S-8264A Series, the CTL pin takes precedence over the overcharge detection circuit.

In the S-8264B Series, when the CTL pin is switched from “L” to “H”, a reset signal is output to the overcharge detection latch and CO becomes “L”.

Table 11 Control via CTL Pin

CTL Pin	CO Pin	
	S-8264A Series	S-8264B Series
“H”	Normal state ^{*1}	Without latch
Open	“H”	Normal state ^{*1}
“L”	“H”	Normal state ^{*1}
“L” → “H”	–	Latch reset ^{*2}
“H” → “L”	–	–

*1. The state is controlled by the overcharge detection circuit.

*2. Latch reset becomes effective when the voltages of all the batteries are lower than the total of the overcharge detection voltage (V_{CU}) and the overcharge hysteresis voltage (V_{HC}) and the overcharge release delay time (t_{CL}) has elapsed.

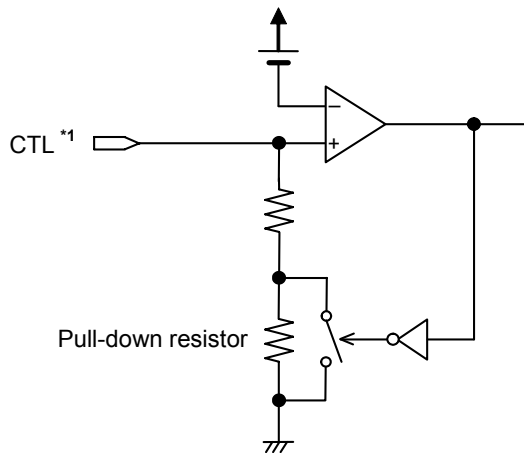

*1. The reverse voltage “H” to “L” or “L” to “H” of CTL pin is VDD pin voltage – 2.8 V (Typ.), does not have the hysteresis.

Figure 7 Internal Equivalent Circuit of CTL Pin

- Caution**
1. Since the CTL pin implements high resistance of 8 MΩ to 12 MΩ for pull down, be careful of external noise application. If an external noise is applied, CO may become “H”. Perform thorough evaluation using the actual application.
 2. In the S-8264B Series, when the CTL pin is open or “L”, CO latches “H”. When the VDD pin voltage is decreased to the UVLO voltage of 2 V (Typ.) or lower, the latch is reset.

4. Test Mode

In the S-8264A/B Series, the overcharge detection delay time (t_{CU}) can be shortened by entering the test mode. The test mode can be set by retaining the VDD pin voltage 8.5 V or more higher than the SENSE pin voltage for at least 80 ms ($V_1 = V_2 = V_3 = V_4 = 3.5\text{ V}$, $T_a = 25\text{ }^\circ\text{C}$). The status is retained by the internal latch and the test mode is retained even if the VDD pin voltage is decreased to the same voltage as that of the SENSE pin. When CO becomes “H” when the delay time has elapsed after overcharge detection, the latch for retaining the test mode is reset and the S-8264A/B Series exits from the test mode.

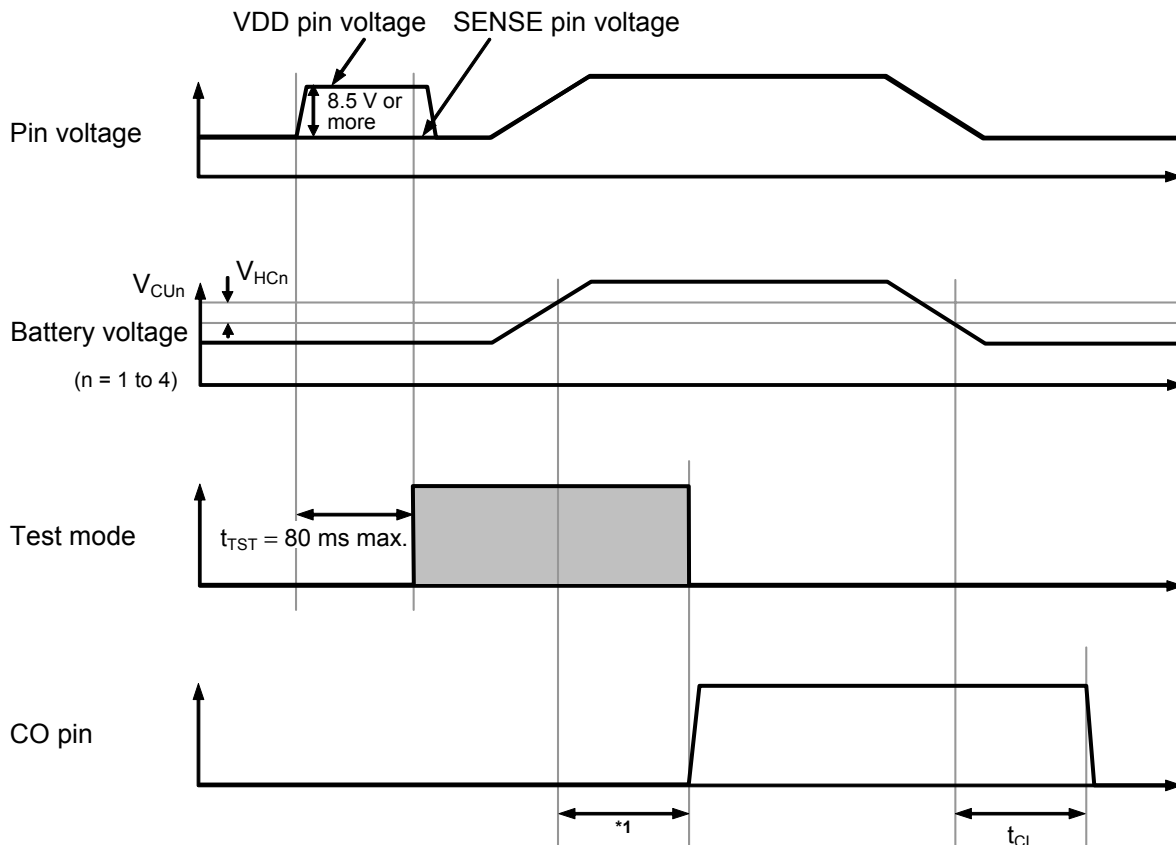

*1. In the product $t_{CU} = 4\text{ s Typ.}$ during normal mode, $t_{CU} = 64\text{ ms Typ.}$
 In the product $t_{CU} = 2\text{ s Typ.}$ during normal mode, $t_{CU} = 32\text{ ms Typ.}$
 In the product $t_{CU} = 5.65\text{ s Typ.}$ during normal mode, $t_{CU} = 88\text{ ms Typ.}$

Figure 8

- Caution**
1. When the VDD pin voltage is decreased to lower than the UVLO voltage of 2 V (Typ.), the S-8264A/B Series returns to the normal mode.
 2. Set the test mode when no batteries are overcharged.
 3. The overcharge release delay time (t_{CL}) is not shortened in the test mode.
 4. The overcharge timer reset delay time (t_{TR}) is not shortened in the test mode.

■ Timing Charts

1. Overcharge Detection Operation

(1) S-8264A Series

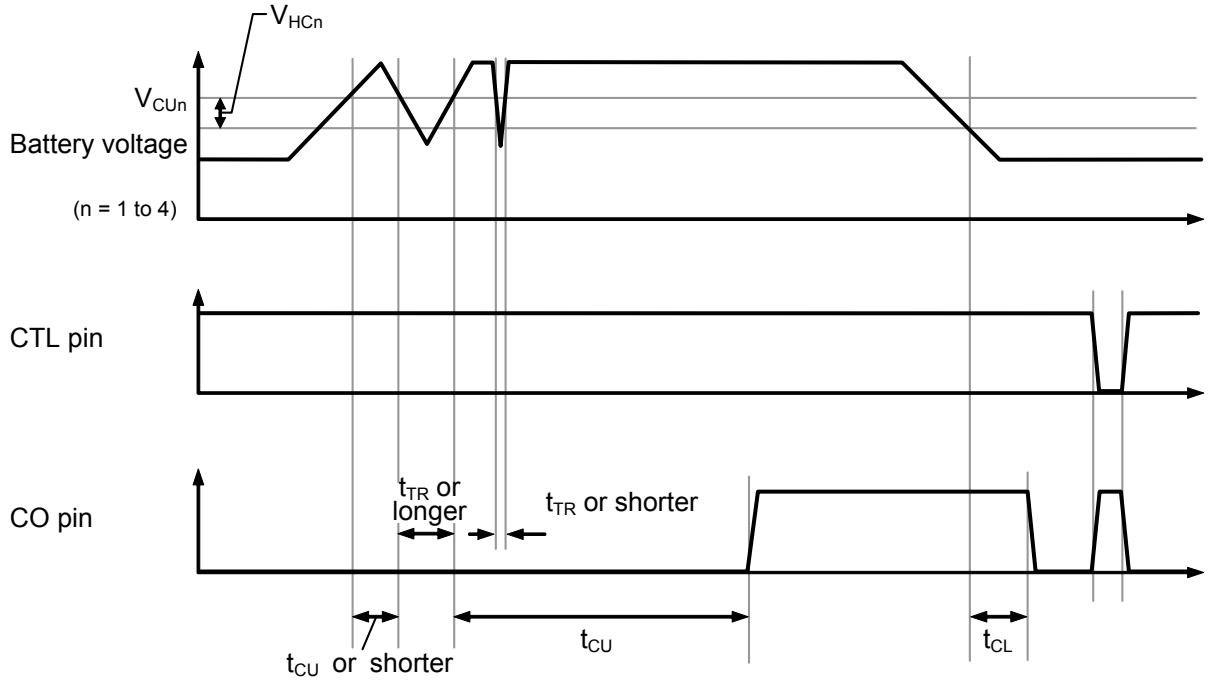

Figure 9

(2) S-8264B Series

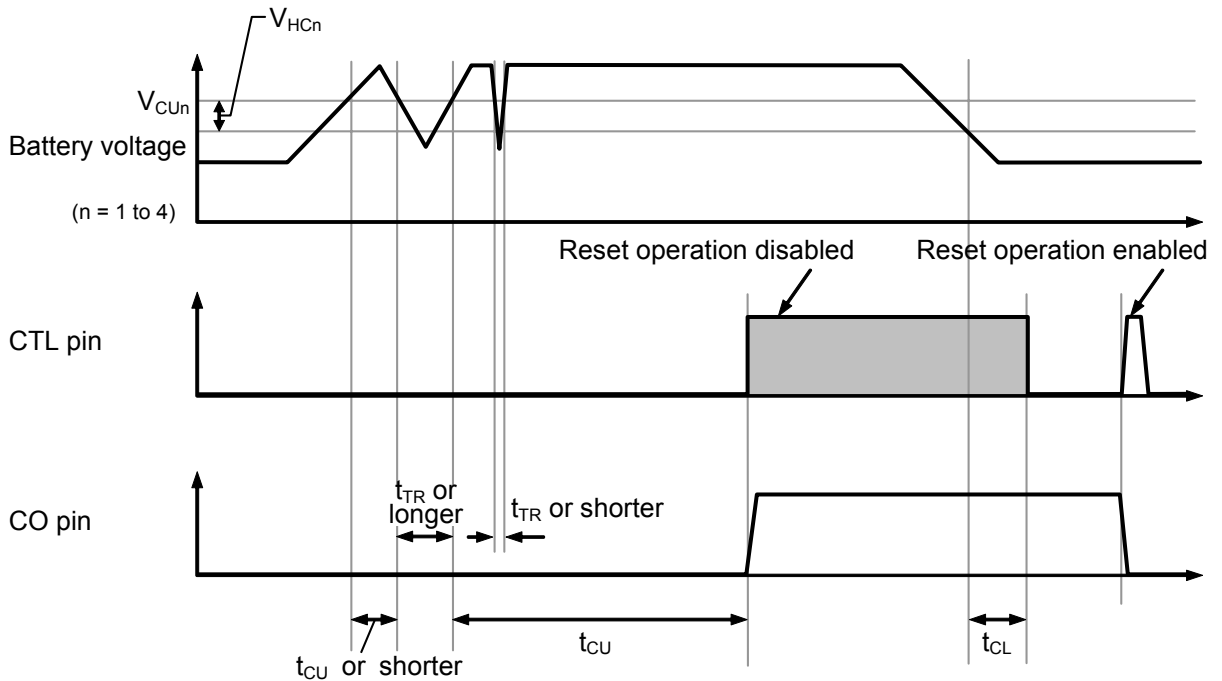

Figure 10

2. Overcharge Timer Reset Operation

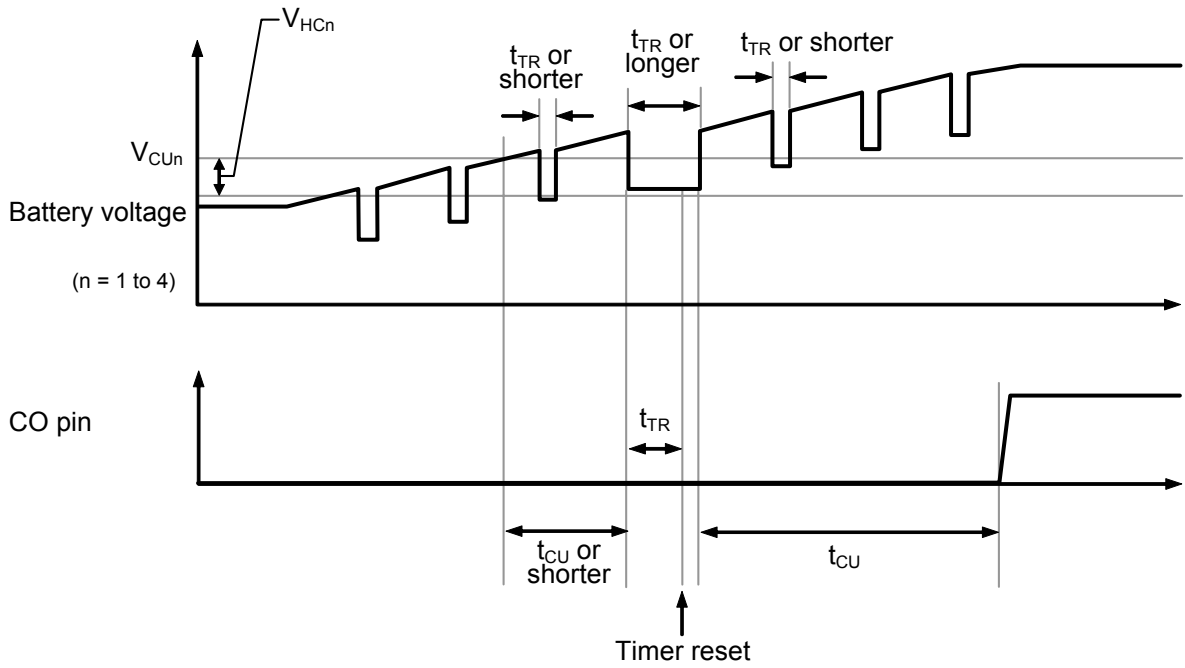

Figure 11

■ Battery Protection IC Connection Example

(1) 4-serial cell

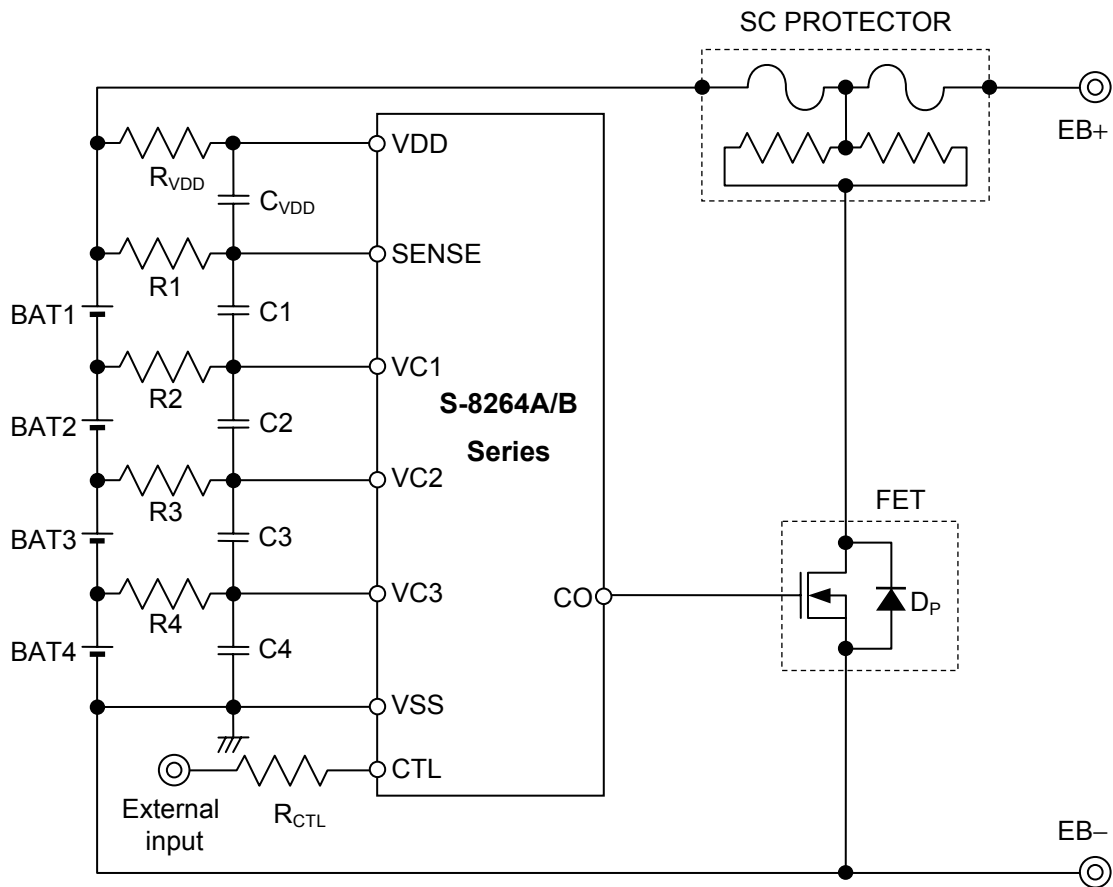

Figure 12

Table 12 Constants for External Components

No.	Part	Min.	Typ.	Max.	Unit
1	R1 to R4	0.1	1	10	kΩ
2	C1 to C4, C _{VDD}	0.01	0.1	1	μF
3	R _{VDD}	50	100	500	Ω
4	R _{CTL}	0	100	500	Ω

- Caution**
1. The above constants are subject to change without prior notice.
 2. It has not been confirmed whether the operation is normal or not in circuits other than the above example of connection. In addition, the example of connection shown above and the constant will not guarantee successful operation. Perform thorough evaluation using the actual application to set the constant.
 3. Set the same constants to R1 to R4 and to C1 to C4 and C_{VDD}.
 4. Set R_{VDD}, C1 to C4, and C_{VDD} so that the condition $(R_{VDD}) \times (C1 \text{ to } C4, C_{VDD}) \geq 5 \times 10^{-6}$ is satisfied.
 5. Set R1 to R4, C1 to C4, and C_{VDD} so that the condition $(R1 \text{ to } R4) \times (C1 \text{ to } C4, C_{VDD}) \geq 1 \times 10^{-4}$ is satisfied.
 6. In the S-8264A Series, normally input “H” to the external input, and input “L” when setting CO to “H”. In the S-8264B Series, normally input “L” to the external input, and input “H” when releasing the latch that maintains CO at “H” after overcharge detection.
 7. Since “H” may be output at CO transiently when the battery is being connected, connect the positive terminal of BAT1 last in order to prevent the three terminal protection fuse from cutoff.

(2) 3-serial cell

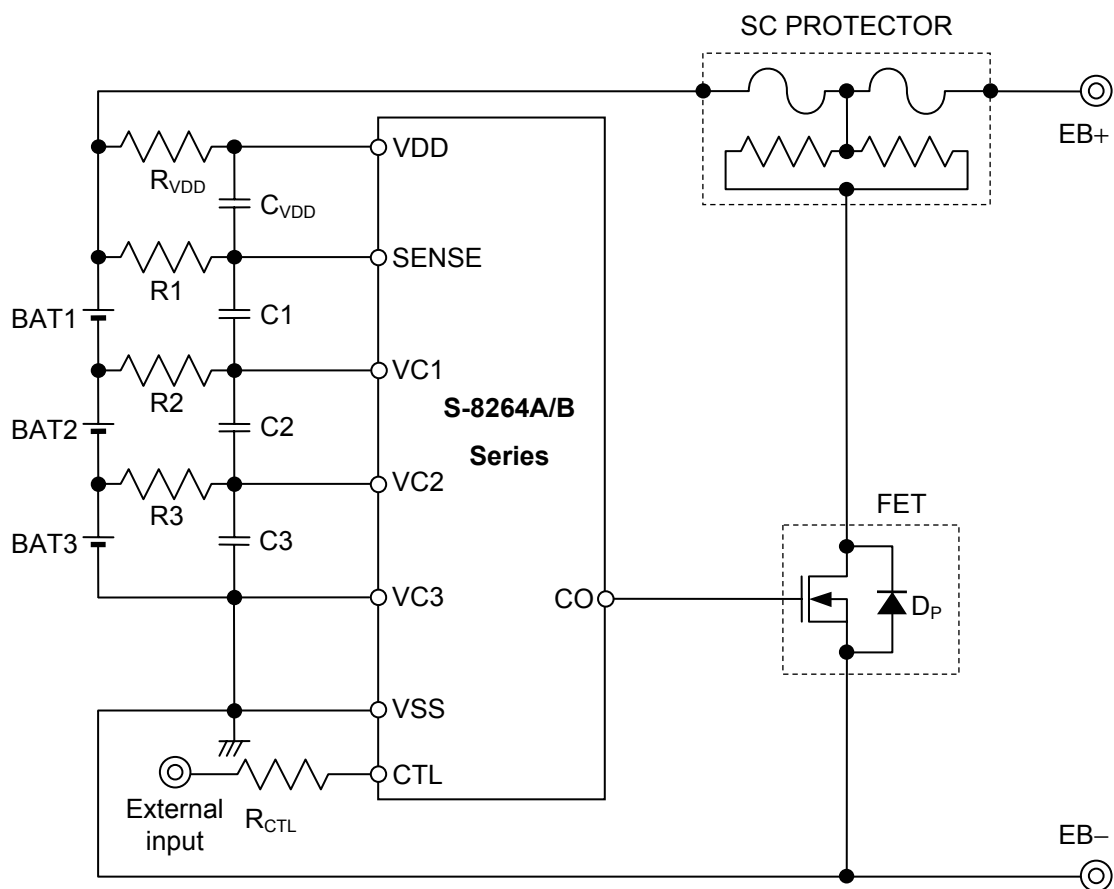

Figure 13

Table 13 Constants for External Components

No.	Part	Min.	Typ.	Max.	Unit
1	R1 to R3	0.1	1	10	kΩ
2	C1 to C3, C _{VDD}	0.01	0.1	1	μF
3	R _{VDD}	50	100	500	Ω
4	R _{CTL}	0	100	500	Ω

- Caution**
1. The above constants are subject to change without prior notice.
 2. It has not been confirmed whether the operation is normal or not in circuits other than the above example of connection. In addition, the example of connection shown above and the constant will not guarantee successful operation. Perform thorough evaluation using the actual application to set the constant.
 3. Set the same constants to R1 to R3 and to C1 to C3 and C_{VDD}.
 4. Set R_{VDD}, C1 to C3, and C_{VDD} so that the condition $(R_{VDD}) \times (C1 \text{ to } C3, C_{VDD}) \geq 5 \times 10^{-6}$ is satisfied.
 5. Set R1 to R3, C1 to C3, and C_{VDD} so that the condition $(R1 \text{ to } R3) \times (C1 \text{ to } C3, C_{VDD}) \geq 1 \times 10^{-4}$ is satisfied.
 6. In the S-8264A Series, normally input "H" to the external input, and input "L" when setting CO to "H". In the S-8264B Series, normally input "L" to the external input, and input "H" when releasing the latch that maintains CO at "H" after overcharge detection.
 7. Since "H" may be output at CO transiently when the battery is being connected, connect the positive terminal of BAT1 last in order to prevent the three terminal protection fuse from cutoff.

(3) 2-serial cell

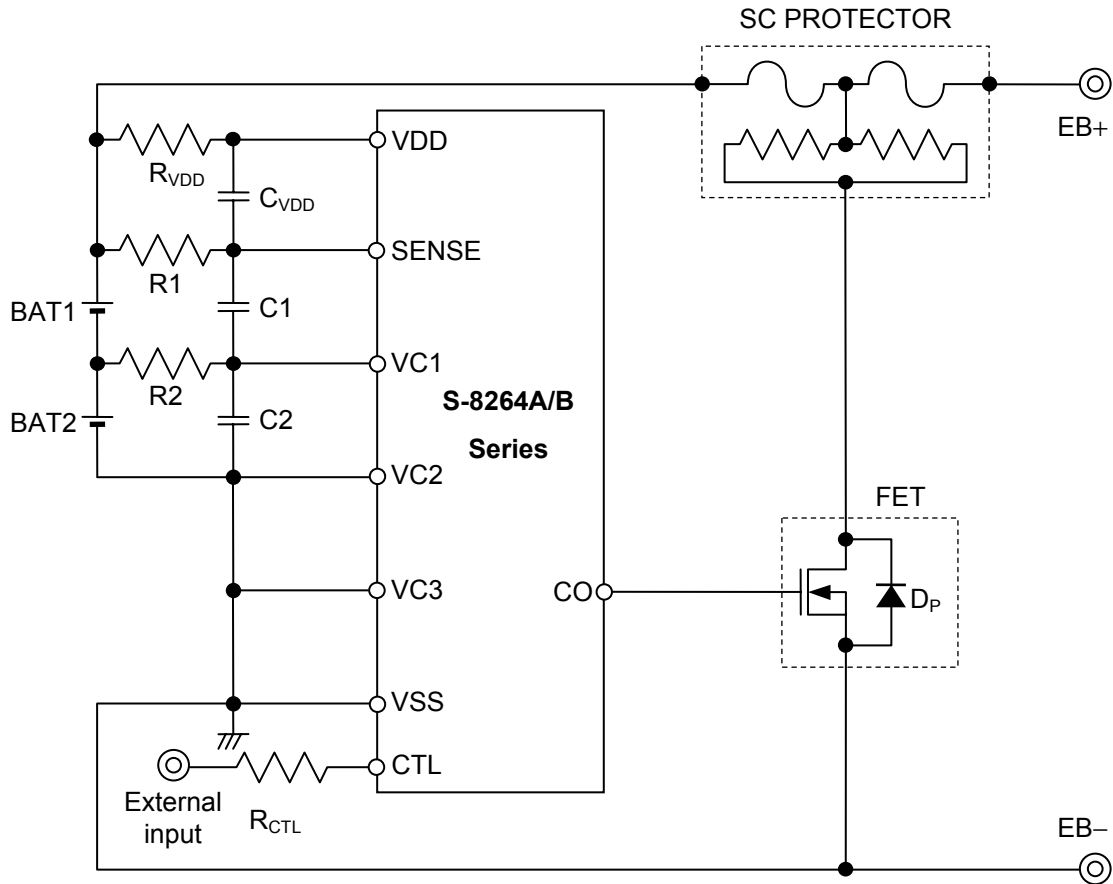

Figure 14

Table 14 Constants for External Components

No.	Part	Min.	Typ.	Max.	Unit
1	R1 and R2	0.1	1	10	kΩ
2	C1 and C2, C _{VDD}	0.01	0.1	1	μF
3	R _{VDD}	50	100	500	Ω
4	R _{CTL}	0	100	500	Ω

- Cautions**
1. The above constants are subject to change without prior notice.
 2. It has not been confirmed whether the operation is normal or not in circuits other than the above example of connection. In addition, the example of connection shown above and the constant will not guarantee successful operation. Perform thorough evaluation using the actual application to set the constant.
 3. Set the same constants to R1 and R2, and to C1 and C2 and C_{VDD}.
 4. Set R_{VDD}, C1, C2, and C_{VDD} so that the condition $(R_{VDD}) \times (C1 \text{ or } C2, C_{VDD}) \geq 5 \times 10^{-6}$ is satisfied.
 5. Set R1, R2, C1, C2, and C_{VDD} so that the condition $(R1 \text{ or } R2) \times (C1 \text{ or } C2, C_{VDD}) \geq 1 \times 10^{-4}$ is satisfied.
 6. In the S-8264A Series, normally input "H" to the external input, and input "L" when setting CO to "H". In the S-8264B Series, normally input "L" to the external input, and input "H" when releasing the latch that maintains CO at "H" after overcharge detection.
 7. Since "H" may be output at CO transiently when the battery is being connected, connect the positive terminal of BAT1 last in order to prevent the three terminal protection fuse from cutoff.

■ Precautions

- Do not connect batteries charged with $V_{CU} + V_{HC}$ or more. If the connected batteries include a battery charged with $V_{CU} + V_{HC}$ or more, “H” may be output at CO after all pins are connected.
- In some application circuits, even if an overcharged battery is not included, the order of connecting batteries may be restricted to prevent transient output of CO detection pulses when the batteries are connected. Perform thorough evaluation with the actual application circuit.
- In the S-8264B Series, “H” may be output at CO after all the pins are connected. In this case, set the CTL pin from “L” to “H”.
- Before the battery connection, short-circuit the battery side pins R_{VDD} and R1, shown in the figure in “**Battery Protection IC Connection Example**”.
- The application conditions for the input voltage, output voltage, and load current should not exceed the package power dissipation.
- Do not apply to this IC an electrostatic discharge that exceeds the performance ratings of the built-in electrostatic protection circuit.
- SII claims no responsibility for any disputes arising out of or in connection with any infringement of patents owned by a third party by products including this IC.

■ Example of Application Circuit

1. Overheat Protection via PTC

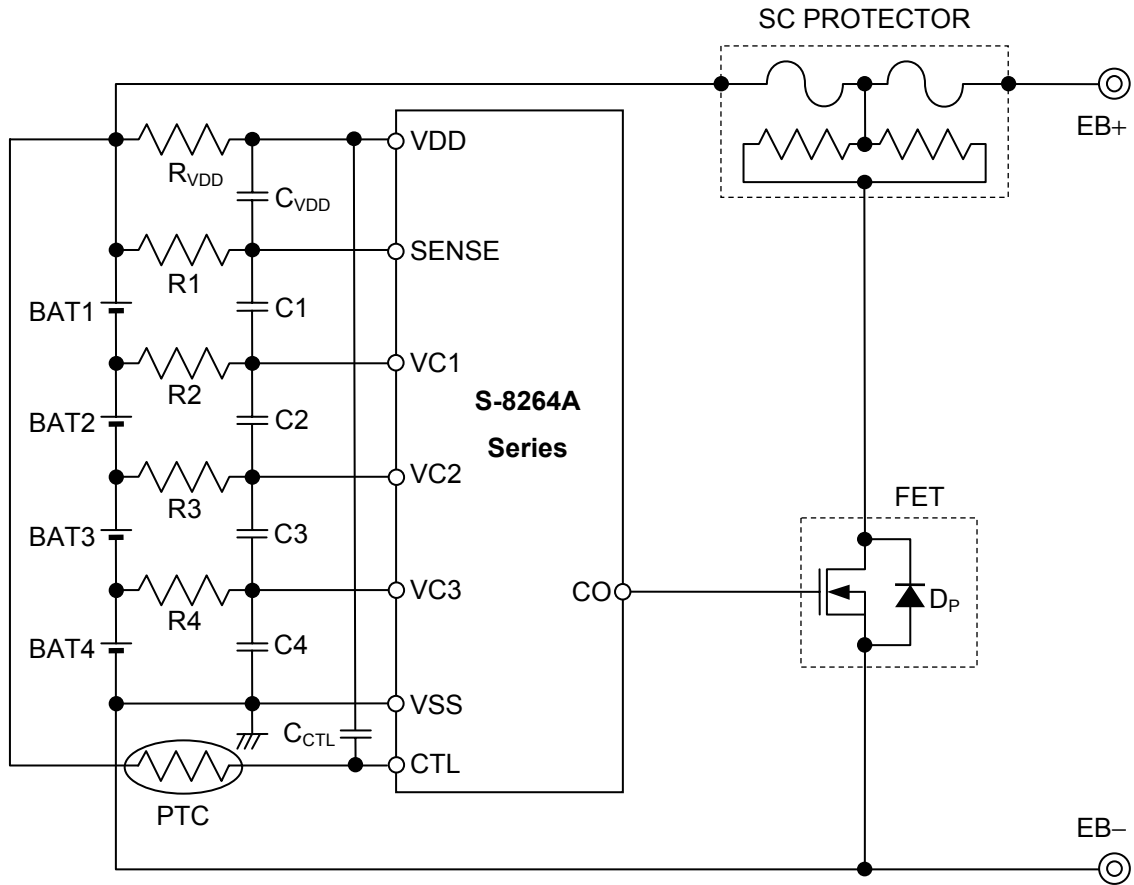

Figure 15

- Cautions**
1. The above connection example will not guarantee successful operation. Perform thorough evaluation using the actual application.
 2. A pull-down resistor is included in the CTL pin. To perform overheat protection via the PTC in the S-8264A Series, connect the PTC before connecting batteries.
 3. When the power fluctuation is large, connect the power supply of the PTC to the VDD pin of the S-8264A Series.
 4. Since “H” may be output at CO transiently when the battery is being connected, connect the positive terminal of BAT1 last in order to prevent the three terminal protection fuse from cutoff.

[For SC PROTECTOR, contact]

Sony Chemical & Information Device Corporation, Electronic Device Marketing & Sales Dept.
 Gate City Osaki East Tower 8F, 1-11-2
 Osaki, Shinagawa-ku, Tokyo, 141-0032 Japan
 TEL +81-3-5435-3943
 Contact Us: <http://www.sonycid.jp/en/>

[For PTC, contact]

Murata Manufacturing Co., Ltd.
 Thermistor Products Department
 Nagaokakyo-shi, Kyoto 617-8555 Japan
 TEL +81-75-955-6863
 Contact Us: <http://www.murata.com/contact/index.html>

■ **Characteristics (Typical Data)**

1. Detection Voltage vs. Temperature

(1) Overcharge Detection Voltage vs. Temperature
 $V_{CU} = 4.3 \text{ V}$

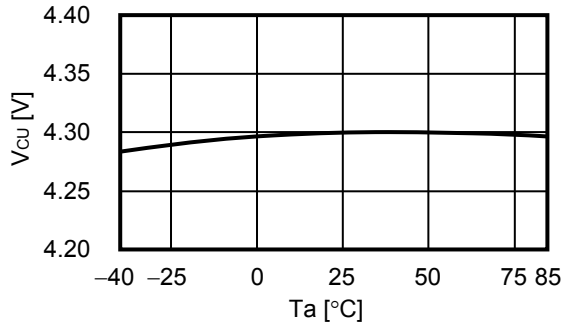

(2) Overcharge Release Voltage vs. Temperature
 $V_{HC} = 0.52 \text{ V}$

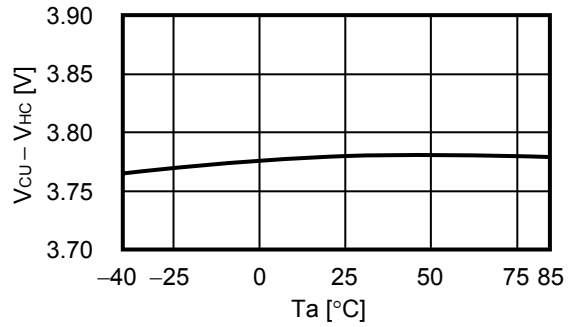

2. Current Consumption vs. Temperature

(1) Current Consumption during Normal Operation vs. Temperature
 $V_{DD} = 14 \text{ V}$

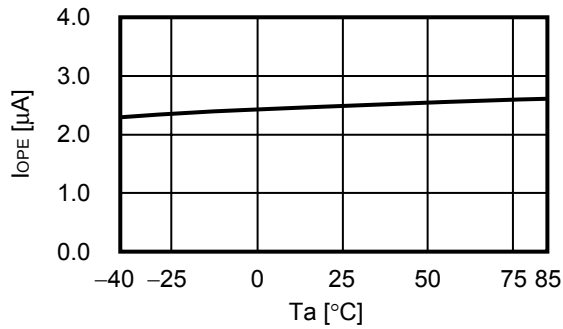

(2) Current Consumption during Overdischarge vs. Temperature
 $V_{DD} = 9.2 \text{ V}$

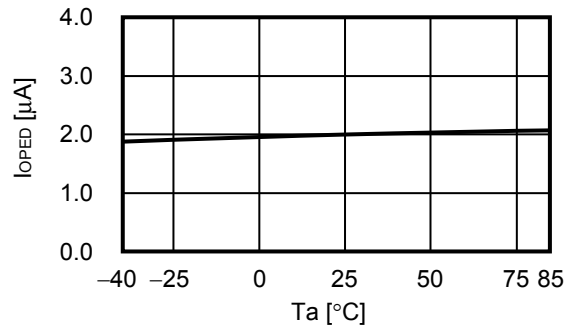

3. Delay Time vs. Temperature

(1) Overcharge Detection Delay Time vs. Temperature
 $V_{DD} = 20 \text{ V}$

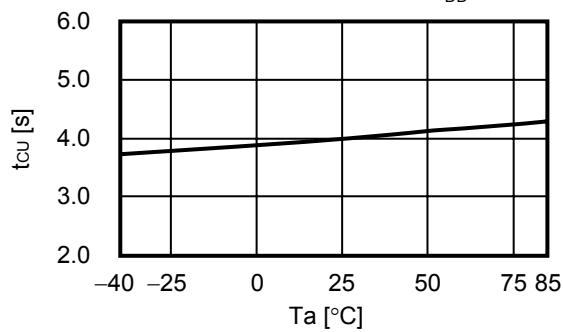

(2) Overcharge Release Delay Time vs. Temperature
 $V_{DD} = 14 \text{ V}$

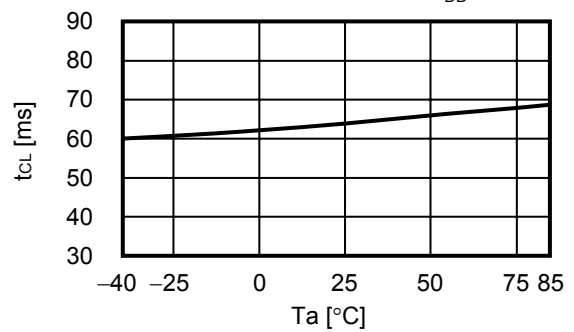

4. Output Current vs. Temperature

(1) CO Pin Sink Current vs. V_{DD}

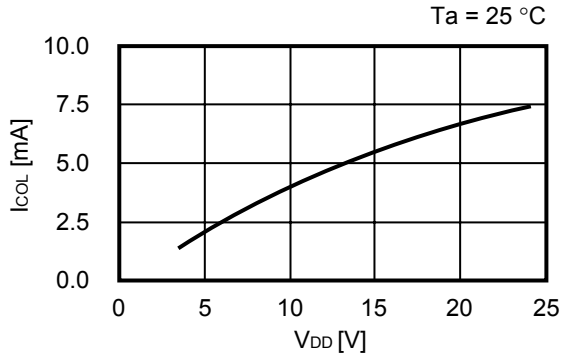

(2) CO Pin Source Current vs. V_{DD}

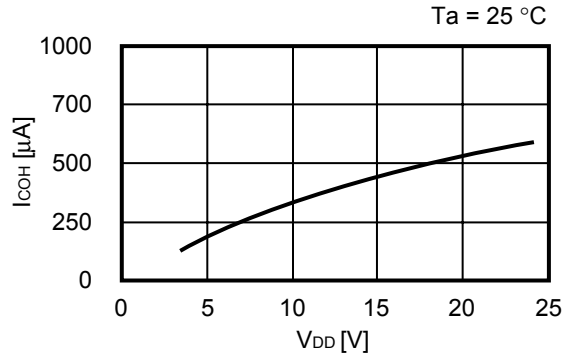

5. CTL Pin vs. Temperature

(1) CTL Pin Threshold Voltage vs. Temperature

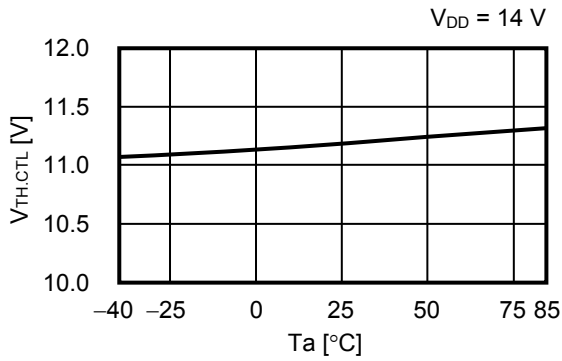

(2) CTL Pin Input Resistance vs. Temperature

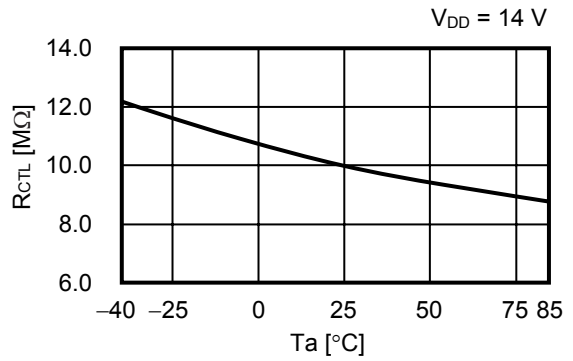

■ **Marking Specifications**

(1) **SNT-8A**

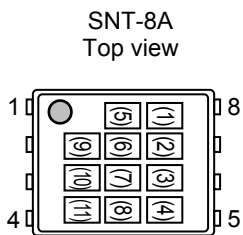

- (1) Blank
- (2) to (4) Product code (Refer to **Product name vs. Product code**)
- (5), (6) Blank
- (7) to (11) Lot number

Product name vs. Product code

Product name	Product code		
	(2)	(3)	(4)
S-8264AAA-I8T1G	Q	5	A
S-8264AAB-I8T1G	Q	5	B
S-8264AAC-I8T1G	Q	5	C
S-8264AAD-I8T1G	Q	5	D
S-8264AAE-I8T1G	Q	5	E
S-8264AAF-I8T1G	Q	5	F
S-8264AAG-I8T1G	Q	5	G
S-8264AAH-I8T1G	Q	5	H
S-8264AAI-I8T1G	Q	5	I
S-8264AAJ-I8T1G	Q	5	J
S-8264AAK-I8T1G	Q	5	K

Product name	Product code		
	(2)	(3)	(4)
S-8264BAA-I8T1G	Q	6	A
S-8264BAB-I8T1G	Q	6	B

(2) **8-Pin TSSOP**

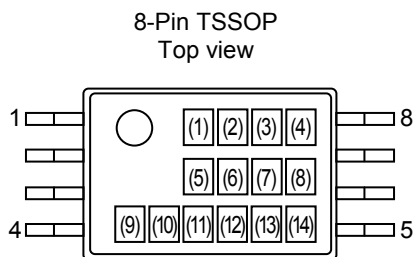

- (1) to (5) Product name: S8264 (Fixed)
- (6) to (8) Function code
- (9) to (14) Lot number

Product name vs. Function code

Product name	Function code		
	(6)	(7)	(8)
S-8264AAA-T8T1G	A	A	A
S-8264AAB-T8T1G	A	A	B

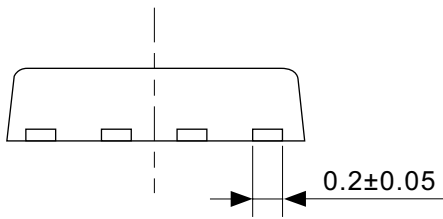
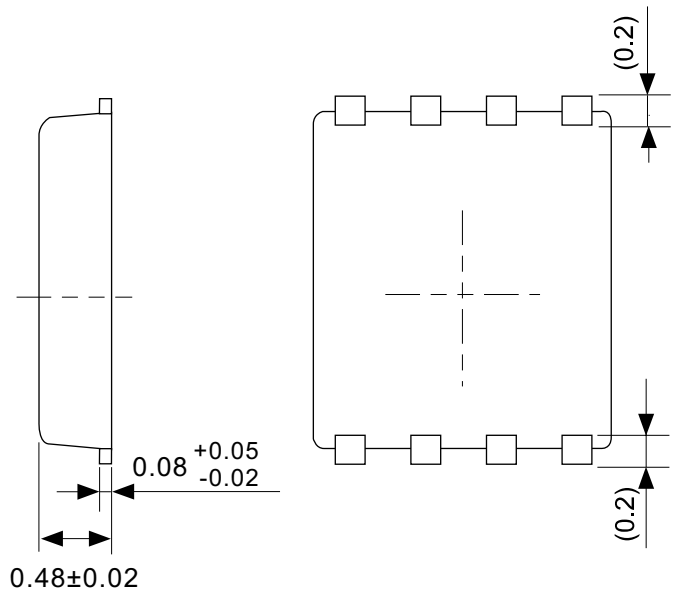
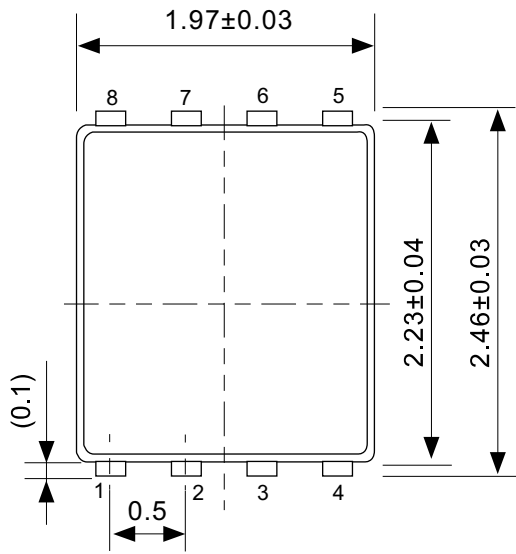

No. PH008-A-P-SD-2.0

TITLE	SNT-8A-A-PKG Dimensions
No.	PH008-A-P-SD-2.0
SCALE	
UNIT	mm
Seiko Instruments Inc.	

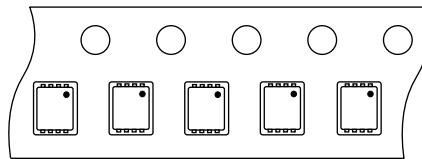
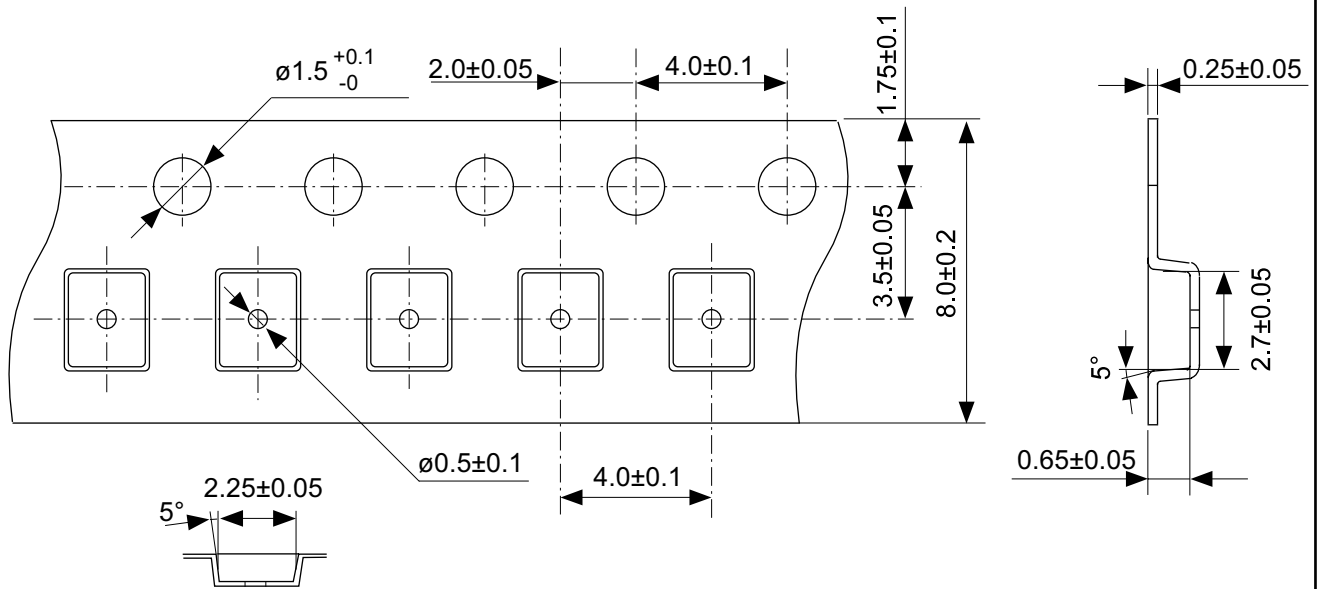

Feed direction

No. PH008-A-C-SD-1.0

TITLE	SNT-8A-A-Carrier Tape
No.	PH008-A-C-SD-1.0
SCALE	
UNIT	mm
Seiko Instruments Inc.	

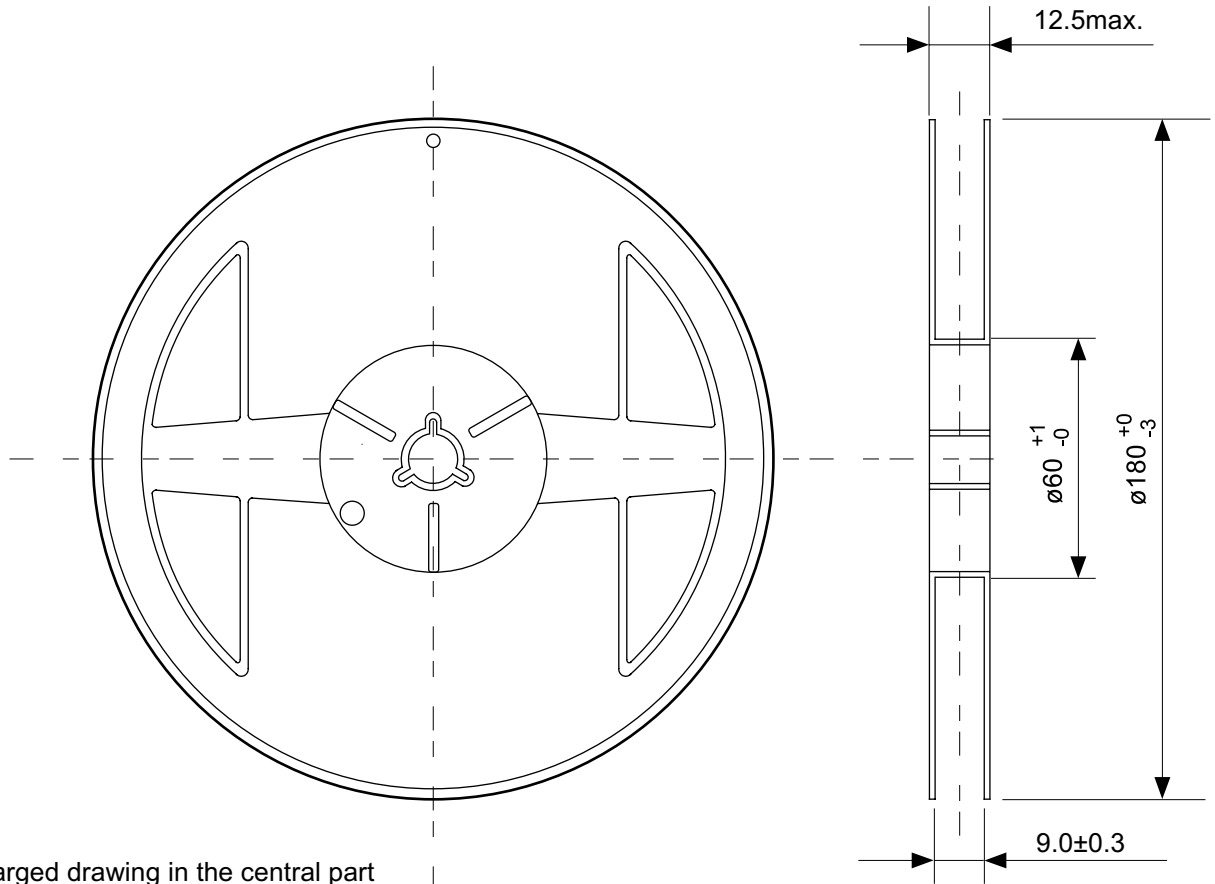

Enlarged drawing in the central part

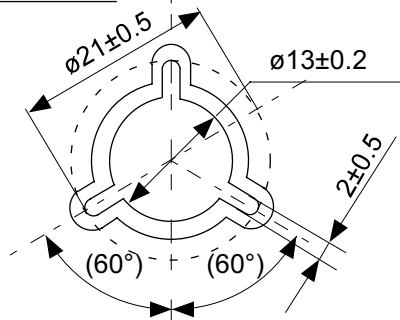

No. PH008-A-R-SD-1.0

TITLE	SNT-8A-A-Reel		
No.	PH008-A-R-SD-1.0		
SCALE		QTY.	5,000
UNIT	mm		
Seiko Instruments Inc.			

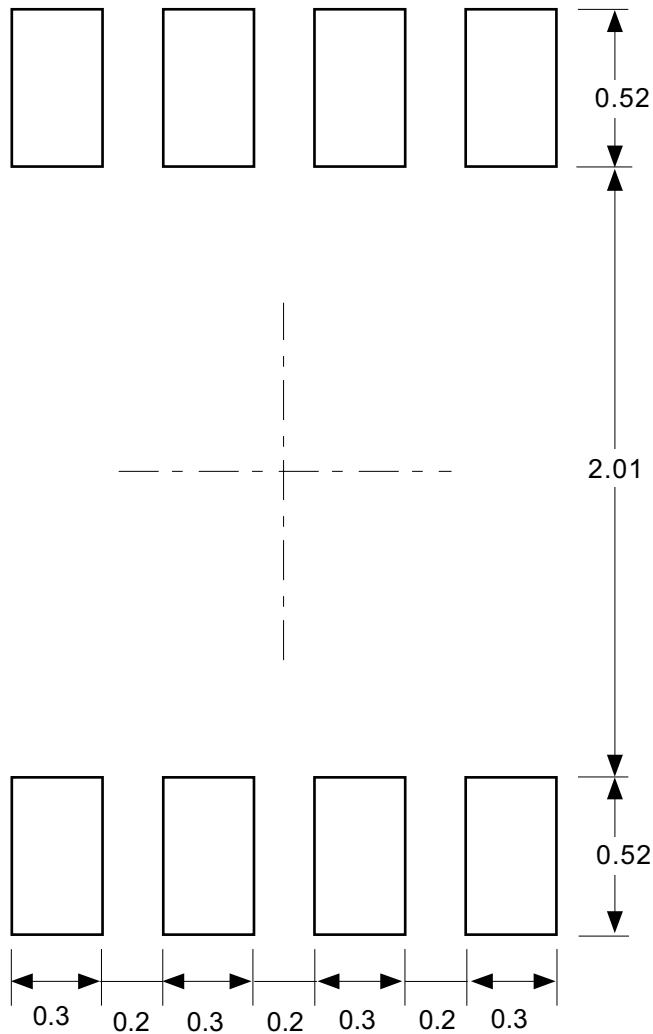

Caution Making the wire pattern under the package is possible. However, note that the package may be upraised due to the thickness made by the silk screen printing and of a solder resist on the pattern because this package does not have the standoff.

注意 パッケージ下への配線パターン形成は可能ですが、本パッケージはスタンドオフが無いので、パターン上のレジスト厚み、シルク印刷の厚みによってパッケージが持ち上がる場合がありますのでご配慮ください。

No. PH008-A-L-SD-3.0

TITLE	SNT-8A-A-Land Recommendation
No.	PH008-A-L-SD-3.0
SCALE	
UNIT	mm
Seiko Instruments Inc.	

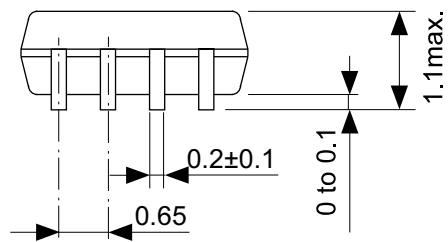
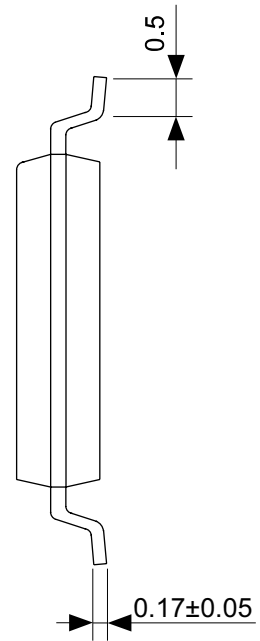
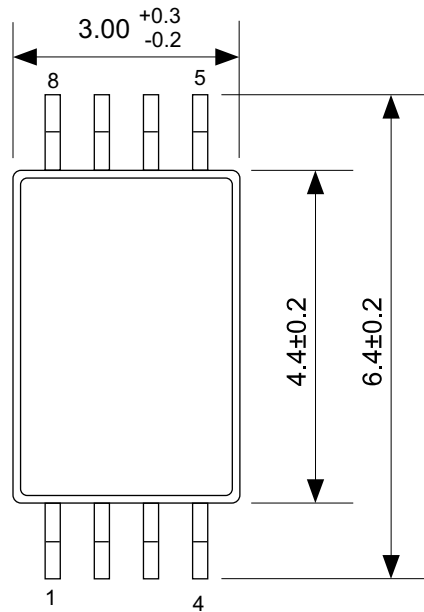

No. FT008-A-P-SD-1.1

TITLE	TSSOP8-E-PKG Dimensions
No.	FT008-A-P-SD-1.1
SCALE	
UNIT	mm
Seiko Instruments Inc.	

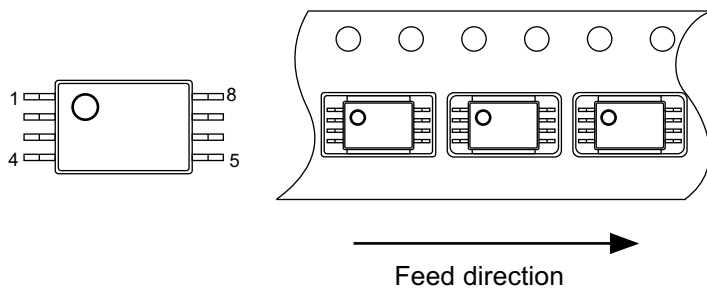
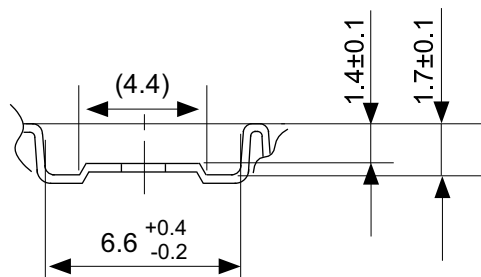
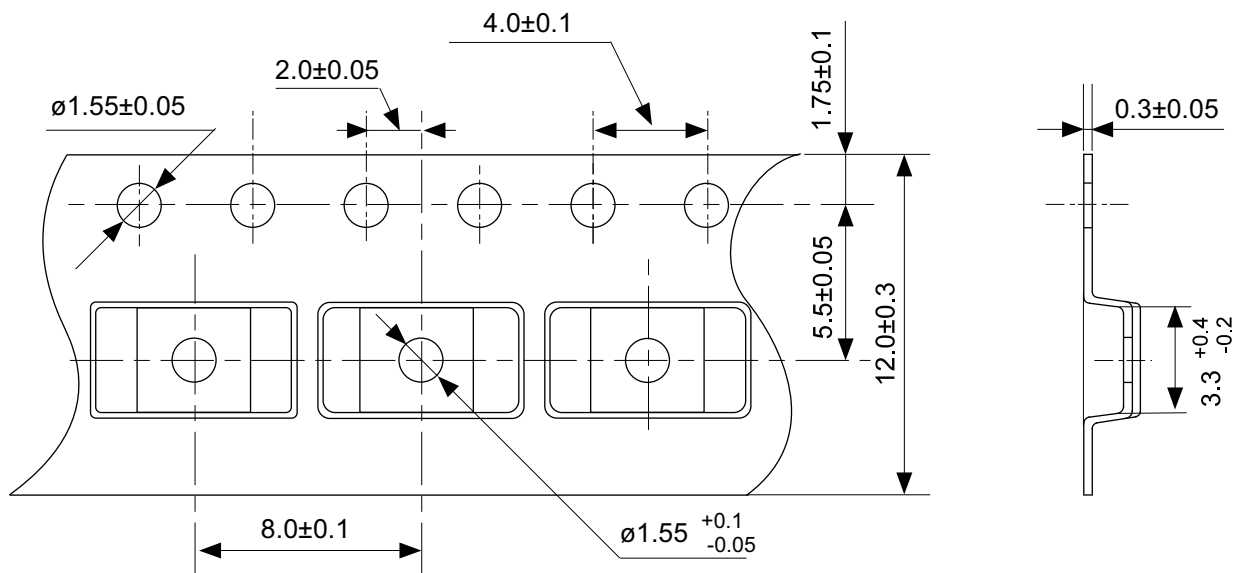

No. FT008-E-C-SD-1.0

TITLE	TSSOP8-E-Carrier Tape
No.	FT008-E-C-SD-1.0
SCALE	
UNIT	mm
Seiko Instruments Inc.	

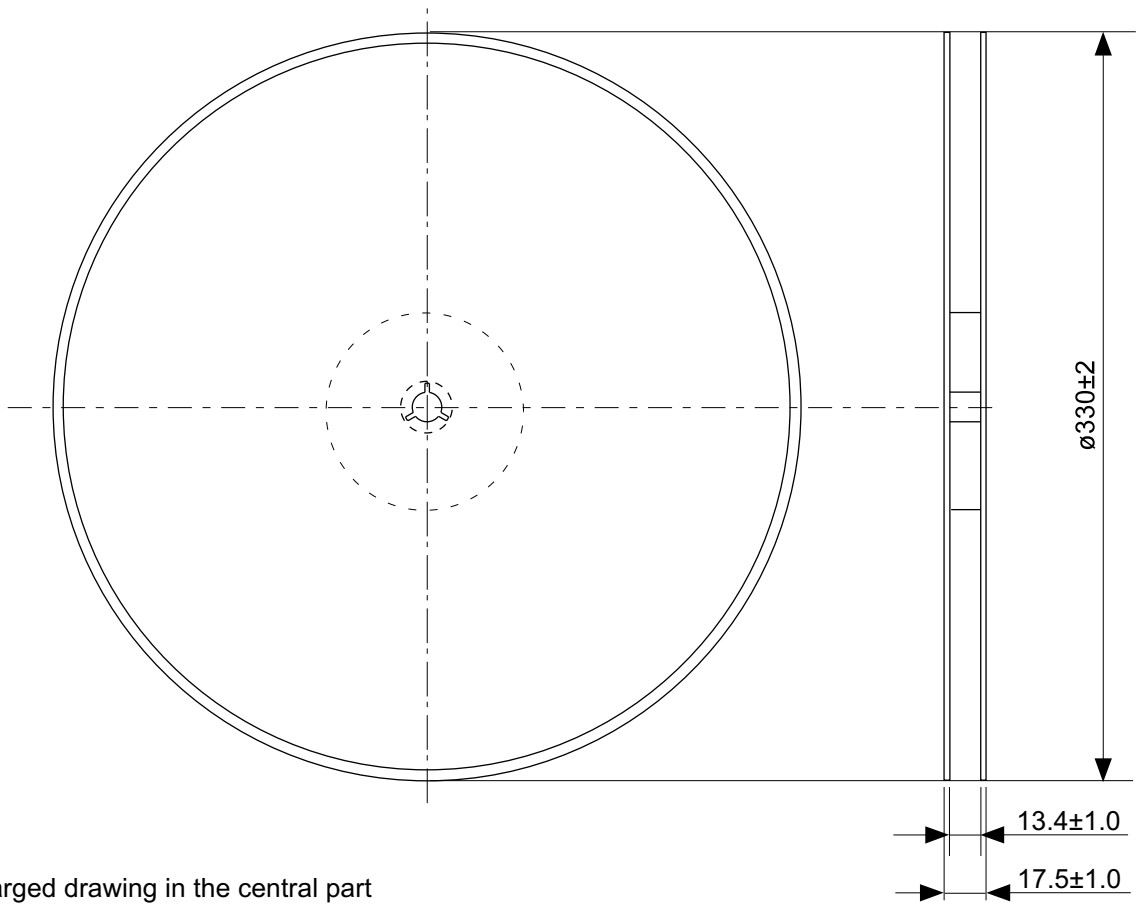

Enlarged drawing in the central part

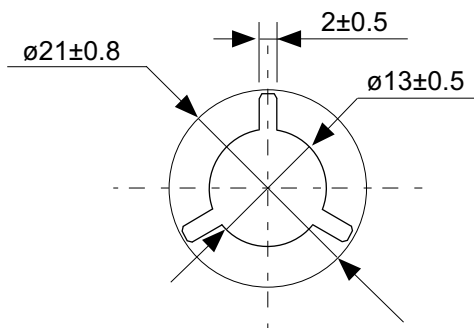

No. FT008-E-R-SD-1.0

TITLE	TSSOP8-E-Reel		
No.	FT008-E-R-SD-1.0		
SCALE		QTY.	3,000
UNIT	mm		
Seiko Instruments Inc.			

- The information described herein is subject to change without notice.
- Seiko Instruments Inc. is not responsible for any problems caused by circuits or diagrams described herein whose related industrial properties, patents, or other rights belong to third parties. The application circuit examples explain typical applications of the products, and do not guarantee the success of any specific mass-production design.
- When the products described herein are regulated products subject to the Wassenaar Arrangement or other agreements, they may not be exported without authorization from the appropriate governmental authority.
- Use of the information described herein for other purposes and/or reproduction or copying without the express permission of Seiko Instruments Inc. is strictly prohibited.
- The products described herein cannot be used as part of any device or equipment affecting the human body, such as exercise equipment, medical equipment, security systems, gas equipment, or any apparatus installed in airplanes and other vehicles, without prior written permission of Seiko Instruments Inc.
- Although Seiko Instruments Inc. exerts the greatest possible effort to ensure high quality and reliability, the failure or malfunction of semiconductor products may occur. The user of these products should therefore give thorough consideration to safety design, including redundancy, fire-prevention measures, and malfunction prevention, to prevent any accidents, fires, or community damage that may ensue.