

HIGH WITHSTAND-VOLTAGE VOLTAGE REGULATOR WITH RESET FUNCTION

S-87x Series

The S-87x Series is a low-power high withstand-voltage regulators with a reset function, which integrates high-precision voltage detection and voltage regulation circuits on a single chip. The S-87x Series has lineups for lithium-ion battery packs.

■ Features

- Accuracy of output voltage: $\pm 2.4\%$
2.5 V to 5.8 V (0.1 V step)
- Accuracy of detection voltage: $\pm 2.4\%$ (For the F type, the release voltage is $\pm 1.1\%$)
2.1 V to 11.3 V (0.1 V step)
- Low I/O voltage difference: 0.15 V typ. (at $I_{OUT}=30$ mA, $V_{OUT}=5.0$ V)
0.45 V typ. (at $I_{OUT}=30$ mA, $V_{OUT}=3.0$ V)
- Low current consumption: At Operation mode: 8 μ A max.
At Shutdown mode: 3.5 μ A max. (Available for the C/E/G type)
- Wide operating voltage range: 24 V max.
- Wide operating temperature range: -40°C to $+85^{\circ}\text{C}$
- Built-in delay circuit or shutdown circuit
- Built-in short-circuit protection circuit
- Small package: SOT-89-5
- Lead-free products

■ Applications

- Constant voltage power supply or reset circuit of battery-powered equipment, VTR, camera, communications equipment and others.
- Lithium-ion secondary battery pack

■ Package

Package Name	Drawing Code		
	Package	Tape	Reel
SOT-89-5	UP005-A	UP005-A	UP005-A

■ **Block Diagrams**

1. **A/F type**

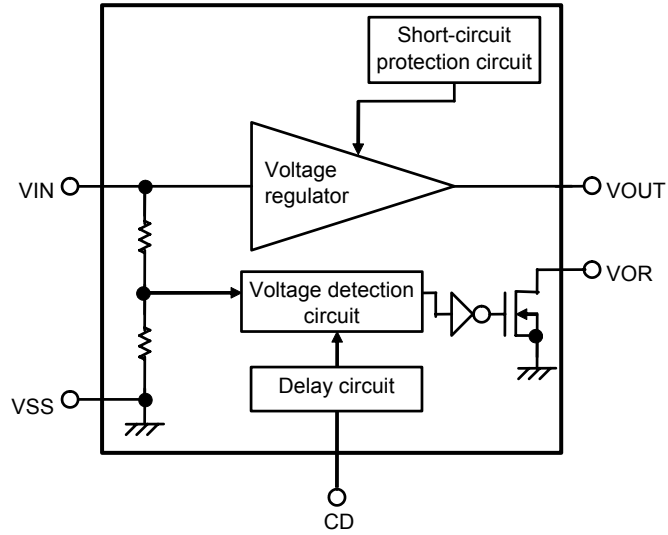

Figure 1

2. **B type**

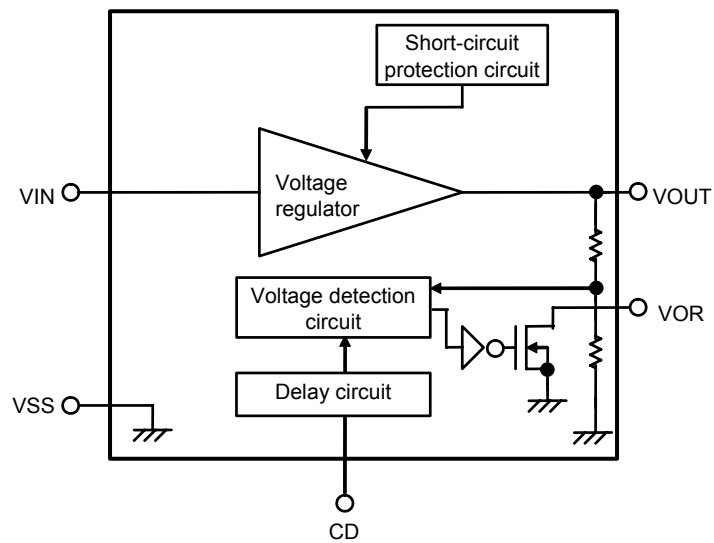

Figure 2

3. C type

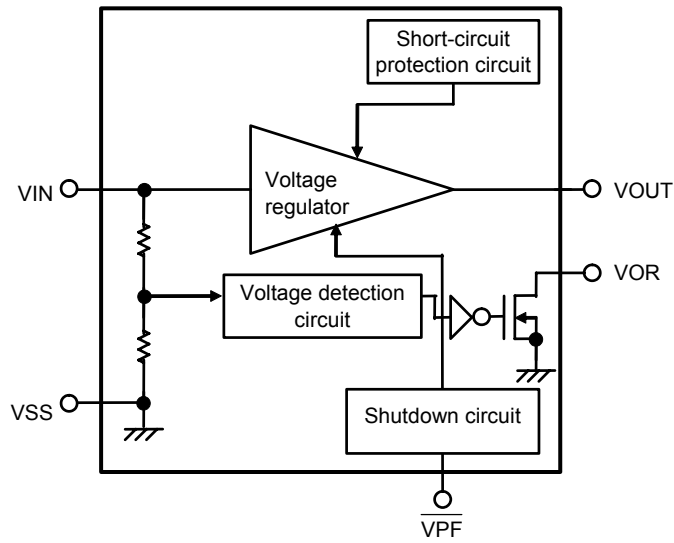

Figure 3

4. E type

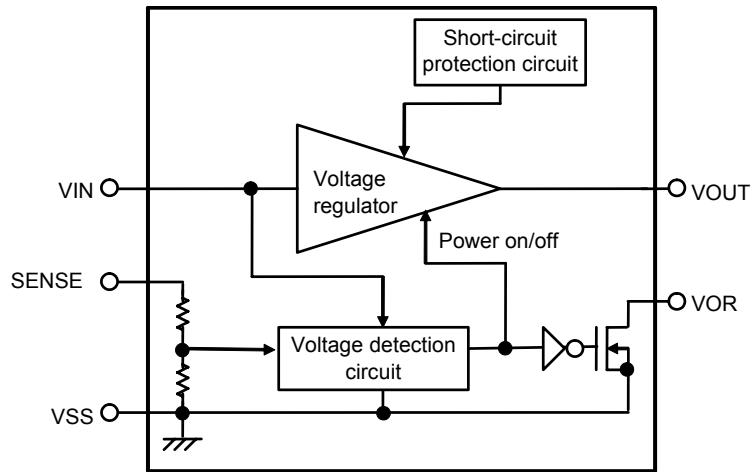

Figure 4

5. G type

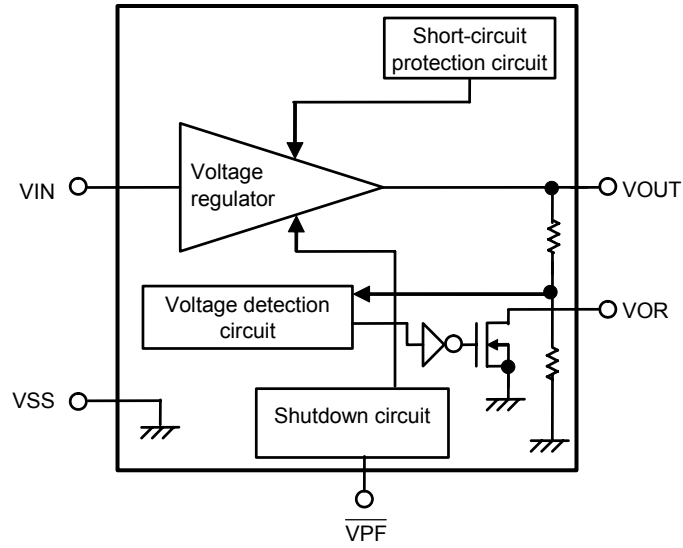

Figure 5

■ Product Name Structure

1. Function list

Table 1

Type name	Voltage detector (VD)	Detection voltage ($-V_{DET}$) accuracy [%]	Release voltage ($+V_{DET}$) accuracy [%]	Built-in delay circuit	Shutdown function	
					VR	VD
A type	Detects V_{IN}	± 2.4	—	Yes	No	No
B type	Detects V_{OUT}	± 2.4	—	Yes	No	No
C type	Detects V_{IN}	± 2.4	—	No	Yes	No
E type	Detects V_{SENSE}	± 2.4	—	No	Yes	No
F type	Detects V_{IN}	—	± 1.1	Yes	No	No
G type	Detects V_{OUT}	± 2.4	—	No	Yes	No

2. Product name selection guide

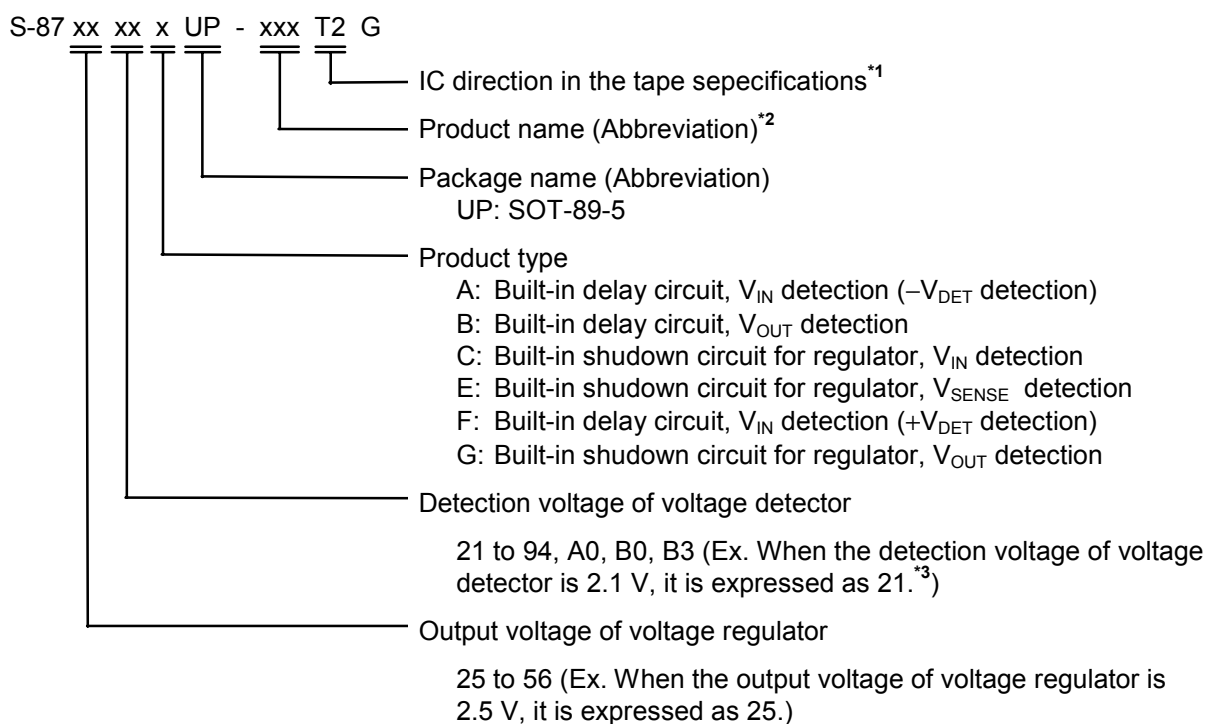

*1. Refer to the taping specifications at the end of this document.

*2. Refer to the **Table 2** to **Table 3** in the “**3. Product name list**”.

*3. A0 for 10.0 V, B0 for 11.0 V, B3 for 11.3 V.

3. Product name list

Table 2 (1/2)

VR output voltage [V]	VD detection voltage [V]	S-87xxxxA Series	S-87xxxxB Series	S-87xxxxC Series	
5.6	3.5	—	S-875635BUP-AGAT2G	—	
5.2	9.4	—	—	S-875294CUP-AHCT2G	
	7.1	—	—	S-875271CUP-AHAT2G	
	5.5	—	—	S-875255CUP-AHBT2G	
5.0	11.0	—	—	S-8750B0CUP-ACGT2G	
	7.7	S-875077AUP-AAFT2G	—	S-875077CUP-ACFT2G	
	6.1	—	—	S-875061CUP-ACHT2G	
	4.5	S-875045AUP-AAAT2G	S-875045BUP-ABAT2G	S-875045CUP-ACAT2G	
	4.3	S-875043AUP-AABT2G	S-875043BUP-ABBT2G	S-875043CUP-ACBT2G	
	4.1	S-875041AUP-AACT2G	S-875041BUP-ABCT2G	S-875041CUP-ACCT2G	
	3.9	S-875039AUP-AADT2G	S-875039BUP-ABDT2G	S-875039CUP-ACDT2G	
	3.7	S-875037AUP-AAET2G	S-875037BUP-ABET2G	S-875037CUP-ACET2G	
	3.4	—	S-875034BUP-ABFT2G	—	
	2.9	—	S-875029BUP-ABHT2G	—	
	2.1	—	S-875021BUP-ABGT2G	—	
	3.3	7.7	S-873377AUP-0AAT2G	—	—
		6.1	—	—	S-873361CUP-AOHT2G
4.1		—	—	S-873341CUP-AOCT2G	
2.8		S-873328AUP-0ABT2G	—	—	
2.5		—	S-873325BUP-ALAT2G	—	
3.0	6.9	—	—	S-873069CUP-AFFT2G	
	5.9	—	—	S-873059CUP-AFGT2G	
	2.5	S-873025AUP-ADAT2G	S-873025BUP-AEAT2G	S-873025CUP-AFAT2G	
	2.4	S-873024AUP-ADBT2G	S-873024BUP-AEBT2G	S-873024CUP-AFBT2G	
	2.3	S-873023AUP-ADCT2G	S-873023BUP-AECT2G	S-873023CUP-AFCT2G	
	2.2	S-873022AUP-ADDT2G	S-873022BUP-AEDT2G	S-873022CUP-AFDT2G	
	2.1	S-873021AUP-ADET2G	S-873021BUP-AEET2G	S-873021CUP-AFET2G	
2.6	2.2	—	S-872622BUP-OLAT2G	—	

Table 2 (2/2)

VR output voltage [V]	VD detection voltage [V]	S-87xxxxE Series	S-87xxxxG Series
5.0	11.0	S-8750B0EUP-AJIT2G	—
	8.7	S-875087EUP-AJGT2G	—
	7.7	S-875077EUP-AJFT2G	—
	6.1	S-875061EUP-AJHT2G	—
	4.2	—	S-875042GUP-ANCT2G
	3.7	—	S-875037GUP-ANET2G
	3.3	S-875033EUP-AJAT2G	—
	3.0	S-875030EUP-AJBT2G	—
3.3	11.0	S-8733B0EUP-APCT2G	—
	10.0	S-8733A0EUP-APFT2G	—
	8.2	S-873382EUP-APHT2G	—
	7.2	S-873372EUP-APET2G	—
	6.4	S-873364EUP-APGT2G	—
	4.8	S-873348EUP-APDT2G	—
	3.0	S-873330EUP-APBT2G	—
3.0	11.3	S-8730B3EUP-AMFT2G	—
	8.2	S-873082EUP-AMCT2G	—
	6.2	S-873062EUP-AMBT2G	—
	5.0	S-873050EUP-AMET2G	—
	4.2	S-873042EUP-AMDT2G	—
2.5	4.8	S-872548EUP-AZBT2G	—
	3.0	S-872530EUP-AZCT2G	—
	2.6	S-872526EUP-AZAT2G	—

Caution In the S-87xxxxB/S-87xxxxG Series, when the output voltage of the voltage regulator is close to the detection voltage of the voltage detector, the transient response of the voltage regulator may cause false detection. Please take transient response into account when deciding voltages.

Table 3

VR output voltage [V]	VD release voltage [V]	S-87xxxxF Series
5.0	8.7	S-875087FUP-AKAT2G

■ Pin Configuration

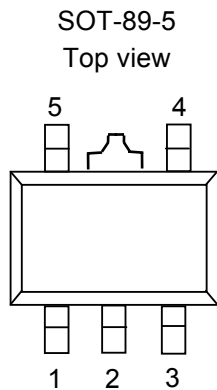

Figure 6

Table 4

Pin No.	Symbol	Description
1	VOUT	Voltage output pin of voltage regulator
2	VSS	Ground pin
3	CD (A/B/F type)	Connection pin of external capacitor for delay of voltage detector
	$\overline{V}PF$ (C/G type)	Input pin of shutdown circuit
	SENSE (E type)	Voltage monitoring pin of voltage detector
4	VOR	Output pin of voltage detector, Nch opendrain output
5	VIN	Positive power-supply

■ Absolute Maximum Ratings

Table 5

(Unless otherwise specified: Ta=25°C)

Item	Symbol	Absolute maximum rating	Unit
Input voltage*1	V _{IN}	V _{SS} -0.3 to V _{SS} +26	V
	V _{CD} (A/B/F type)	V _{SS} -0.3 to V _{IN} +0.3	
	$\overline{V}PF$ (C/G type)	V _{SS} -0.3 to V _{SS} +26	
	V _{SENSE} (E type)		
Output voltage	V _{OUT}	V _{SS} -0.3 to V _{IN} +0.3	°C
Output voltage of voltage detector	V _{OR}	V _{SS} -0.3 to V _{SS} +26	
Power dissipation	P _D	500	
Operating ambient temperature	T _{opr}	-40 to +85	°C
Storage temperature	T _{stg}	-40 to +125	

*1. Even pulse (μs) noise exceeding the above input voltage (V_{SS}+26 V) may damage the IC. Observe the rated input voltage (V_{SS}+26 V).

Caution The absolute maximum ratings are rated values exceeding which the product could suffer physical damage. These values must therefore not be exceeded under any conditions.

■ **Electrical Characteristics**

1. S-8750xxA Series/S-8750xxB Series

Table 6

(Unless otherwise specified: Ta=25°C)

Item	Symbol	Condition	Min.	Typ.	Max.	Unit	Test circuit	
Voltage Regulator								
Output voltage	V_{OUT}	$V_{IN}=7\text{ V}$, $I_{OUT}=30\text{ mA}$	4.88	5.00	5.12	V	1	
I/O voltage difference	V_{dif}	$I_{OUT}=30\text{ mA}$	—	0.15	0.40			
Line regulation	ΔV_{OUT1}	$V_{IN}=6\text{ to }24\text{ V}$, $I_{OUT}=30\text{ mA}$	—	15	50	mV		
Load regulation	ΔV_{OUT2}	$V_{IN}=7\text{ V}$, $I_{OUT}=50\text{ }\mu\text{A to }40\text{ mA}$	—	15	50			
Input voltage	V_{IN}	—	—	—	24	V		
Temperature coefficient of V_{OUT}	$\frac{\Delta V_{OUT}}{\Delta T_a}$	$V_{IN}=7\text{ V}$, $I_{OUT}=30\text{ mA}$, $T_a=-40^\circ\text{C to }+85^\circ\text{C}$	—	± 0.38	± 1.52	mV/ °C		
Voltage Detector								
Operating voltage	V_{opr}	—	1.3	—	24	V	2	
Delay time*1	t_{pd}	$C_D=4.7\text{ nF}$	15	27	41	ms	3	
Tempertue characteristic of $-V_{DET}$	$\frac{\Delta -V_{DET}}{\Delta T_a}$	$T_a=-40^\circ\text{C to }+85^\circ\text{C}$	—	± 0.5	± 2.0	mV/ °C	2	
Detection voltage	$-V_{DET}$	S-875045A/B	4.392	4.50	4.608	V		
		S-875043A/B	4.196	4.30	4.404			
		S-875041A/B	4.001	4.10	4.199			
		S-875039A/B	3.806	3.90	3.994			
		S-875037A/B	3.611	3.70	3.789			
		S-875021B	2.049	2.10	2.151			
Sink current	I_{DOUT}	Nch, $V_{DS}=0.5\text{ V}$	$V_{IN}=1.3\text{ V}$	0.25	0.60	—	mA	4
			$V_{IN}=2.4\text{ V}$	1.50	2.60	—		
			$V_{IN}=3.6\text{ V}$	3.00	4.50	—		
Leakage current	I_{LEAK}	Nch, $V_{DS}=24\text{ V}$, $V_{IN}=10\text{ V}$	—	—	0.1	μA		
Hysteresis width	V_{HYS}	S-875045A/B	$-V_{DET}$ $\times 0.01$	—	$-V_{DET}$ $\times 0.025$	V	2	
		S-875043A/B to S-875021A/B	$-V_{DET}$ $\times 0.03$	—	$-V_{DET}$ $\times 0.08$			
Input current								
Current consumption*2	I_{SS}	$V_{IN}=7\text{ V}$, Unloaded	—	3	8	μA	5	

*1. $t_{pd}\text{ (ms)}=(3.18\text{ min.}, 5.74\text{ typ.}, 8.73\text{ max.})\times C_D\text{ (nF)}$

*2. Excluding the charging current of C_D

HIGH WITHSTAND-VOLTAGE VOLTAGE REGULATOR WITH RESET FUNCTION

S-87x Series

Rev.7.1_00

2. S-8730xxA Series/S-8730xxB Series

Table 7

(Unless otherwise specified: Ta=25°C)

Item	Symbol	Condition	Min.	Typ.	Max.	Unit	Test circuit	
Voltage Regulator								
Output voltage	V_{OUT}	$V_{IN}=5\text{ V}$, $I_{OUT}=30\text{ mA}$	2.928	3.000	3.072	V	1	
I/O voltage difference	V_{dif}	$I_{OUT}=30\text{ mA}$	—	0.45	0.70			
Line regulation	ΔV_{OUT1}	$V_{IN}=4\text{ to }24\text{ V}$, $I_{OUT}=30\text{ mA}$	—	15	50	mV		
Load regulation	ΔV_{OUT2}	$V_{IN}=5\text{ V}$, $I_{OUT}=50\text{ }\mu\text{A to }40\text{ mA}$	—	15	50			
Input voltage	V_{IN}	—	—	—	24	V		
Temperature coefficient of V_{OUT}	$\frac{\Delta V_{OUT}}{\Delta Ta}$	$V_{IN}=5\text{ V}$, $I_{OUT}=30\text{ mA}$, $Ta=-40\text{ }^\circ\text{C to }+85\text{ }^\circ\text{C}$	—	± 0.23	± 0.92	mV/ °C		
Voltage Detector								
Operating voltage	V_{OPR}	—	1.3	—	24	V	2	
Delay time ^{*1}	t_{pd}	$C_D=4.7\text{ nF}$	15	27	41	ms	3	
Temperature characteristic of $-V_{DET}$	$\frac{\Delta -V_{DET}}{\Delta Ta}$	$Ta=-40\text{ }^\circ\text{C to }+85\text{ }^\circ\text{C}$	—	± 0.3	± 1.2	mV/ °C	2	
Detection voltage	$-V_{DET}$	S-873025A/B	2.440	2.500	2.560	V		
		S-873024A/B	2.342	2.400	2.458			
		S-873023A/B	2.244	2.300	2.356			
		S-873022A/B	2.147	2.200	2.253			
		S-873021A/B	2.049	2.100	2.151			
Sink current	I_{DOUT}	Nch, $V_{DS}=0.5\text{ V}$	$V_{IN}=1.3\text{ V}$ Other than below	0.25	0.60	—	mA	4
			$V_{IN}=2.4\text{ V}$ S-873025A/B	1.50	2.60	—		
Leakage current	I_{LEAK}	Nch, $V_{DS}=24\text{ V}$, $V_{IN}=10\text{ V}$	—	—	0.1	μA		
Hysteresis width	V_{HYS}	—	$-V_{DET}$ $\times 0.03$	—	$-V_{DET}$ $\times 0.08$	V	2	
Input current								
Current consumption ^{*2}	I_{SS}	$V_{IN}=5\text{ V}$, Unloaded	—	3	8	μA	5	

*1. t_{pd} (ms)=(3.18 min., 5.74 typ., 8.73 max.) $\times C_D$ (nF)

*2. Excluding the charging current of C_D

HIGH WITHSTAND-VOLTAGE VOLTAGE REGULATOR WITH RESET FUNCTION

Rev.7.1_00

S-87x Series

3. S-875635B

Table 8

(Unless otherwise specified: Ta=25°C)

Item	Symbol	Condition	Min.	Typ.	Max.	Unit	Test circuit
Voltage Regulator							
Output voltage	V_{OUT}	$V_{IN}=7.6\text{ V}$, $I_{OUT}=30\text{ mA}$	5.465	5.60	5.735	V	1
I/O voltage difference	V_{dif}	$I_{OUT}=30\text{ mA}$	—	0.15	0.40		
Line regulation	ΔV_{OUT1}	$V_{IN}=6.6\text{ to }24\text{ V}$, $I_{OUT}=30\text{ mA}$	—	15	50	mV	
Load regulation	ΔV_{OUT2}	$V_{IN}=7.6\text{ V}$, $I_{OUT}=50\text{ }\mu\text{A to }40\text{ mA}$	—	15	50		
Input voltage	V_{IN}	—	—	—	24	V	
Temperature coefficient of V_{OUT}	$\frac{\Delta V_{OUT}}{\Delta Ta}$	$V_{IN}=7.6\text{ V}$, $I_{OUT}=30\text{ mA}$, $Ta=-40^\circ\text{C to }+85^\circ\text{C}$	—	± 0.43	± 1.72	mV / °C	
Voltage Detector							
Operating voltage	V_{opr}	—	1.3	—	24	V	2
Delay time*1	t_{pd}	$C_D=4.7\text{ nF}$	15	27	41	ms	3
Temperature characteristic of $-V_{DET}$	$\frac{\Delta -V_{DET}}{\Delta Ta}$	$Ta=-40^\circ\text{C to }+85^\circ\text{C}$	—	± 0.3	± 1.2	mV / °C	2
Detection voltage	$-V_{DET}$	—	3.416	3.50	3.584	V	
Sink current	I_{DOUT}	Nch, $V_{DS}=0.5\text{ V}$	$V_{IN}=1.3\text{ V}$ 0.25	$V_{IN}=2.4\text{ V}$ 0.60	—	mA	4
Leakage current	I_{LEAK}	Nch, $V_{DS}=24\text{ V}$, $V_{IN}=10\text{ V}$	—	—	0.1	μA	
Hysteresis width	V_{HYS}	—	$-V_{DET}$ $\times 0.03$	—	$-V_{DET}$ $\times 0.08$	V	2
Input current							
Current consumption*2	I_{SS}	$V_{IN}=7.6\text{ V}$, Unloaded	—	4	8	μA	5

*1. $t_{pd}\text{ (ms)}=(3.18\text{ min.}, 5.74\text{ typ.}, 8.73\text{ max.})\times C_D\text{ (nF)}$

*2. Excluding the charging current of C_D

4. S-873325B

Table 9

(Unless otherwise specified: Ta=25°C)

Item	Symbol	Condition	Min.	Typ.	Max.	Unit	Test circuit
Voltage Regulator							
Output voltage	V_{OUT}	$V_{IN}=5.3\text{ V}$, $I_{OUT}=30\text{ mA}$	3.220	3.300	3.380	V	1
I/O voltage difference	V_{dif}	$I_{OUT}=30\text{ mA}$	—	0.45	0.70		
Line regulation	ΔV_{OUT1}	$V_{IN}=4.3\text{ to }24\text{ V}$, $I_{OUT}=30\text{ mA}$	—	15	50	mV	
Load regulation	ΔV_{OUT2}	$V_{IN}=5.3\text{ V}$, $I_{OUT}=50\text{ }\mu\text{A to }40\text{ mA}$	—	15	50		
Input voltage	V_{IN}	—	—	—	24	V	
Temperature coefficient of V_{OUT}	$\frac{\Delta V_{OUT}}{\Delta T_a}$	$V_{IN}=5.3\text{ V}$, $I_{OUT}=30\text{ mA}$, $T_a=-40^\circ\text{C to }+85^\circ\text{C}$	—	± 0.25	± 1.00	mV / °C	
Voltage Detector							
Operating voltage	V_{opr}	—	1.3	—	24	V	2
Delay time*1	t_{pd}	$C_D=4.7\text{ nF}$	15	27	41	ms	3
Temperature characteristic of $-V_{DET}$	$\frac{\Delta -V_{DET}}{\Delta T_a}$	$T_a=-40^\circ\text{C to }+85^\circ\text{C}$	—	± 0.2	± 0.8	mV / °C	2
Detection voltage	$-V_{DET}$	—	2.440	2.500	2.560	V	
Sink current	I_{DOUT}	Nch, $V_{DS}=0.5\text{ V}$, $V_{IN}=1.3\text{ V}$	0.25	0.60	—	mA	4
Leakage current	I_{LEAK}	Nch, $V_{DS}=24\text{ V}$, $V_{IN}=10\text{ V}$	—	—	0.1	μA	
Hysteresis width	V_{HYS}	—	$-V_{DET}$ $\times 0.03$	—	$-V_{DET}$ $\times 0.08$	V	2
Input current							
Current consumption*2	I_{SS}	$V_{IN}=5.3\text{ V}$, Unloaded	—	4	8	μA	5

*1. t_{pd} (ms)=(3.18 min., 5.74 typ., 8.73 max.) $\times C_D$ (nF)

*2. Excluding the charging current of C_D

HIGH WITHSTAND-VOLTAGE VOLTAGE REGULATOR WITH RESET FUNCTION

Rev.7.1_00

S-87x Series

5. S-8750xxC Series/S-875037G

Table 10 (1/2)

(Unless otherwise specified: Ta=25°C)

Item	Symbol	Condition	Min.	Typ.	Max.	Unit	Test circuit	
Voltage Regulator								
Output voltage	V_{OUT}	$V_{IN}=7\text{ V}$, $I_{OUT}=30\text{ mA}$	4.88	5.00	5.12	V	1	
I/O voltage difference	V_{dif}	$I_{OUT}=30\text{ mA}$	—	0.15	0.40			
Line regulation	ΔV_{OUT1}	$V_{IN}=6\text{ to }24\text{ V}$, $I_{OUT}=30\text{ mA}$	—	15	50	mV		
Load regulation	ΔV_{OUT2}	$V_{IN}=7\text{ V}$, $I_{OUT}=50\text{ }\mu\text{A to }40\text{ mA}$	—	15	50			
Input voltage	V_{IN}	—	—	—	24	V		
Temperature coefficient of V_{OUT}	$\frac{\Delta V_{OUT}}{\Delta Ta}$	$V_{IN}=7\text{ V}$, $I_{OUT}=30\text{ mA}$, $Ta=-40^{\circ}\text{C to }+85^{\circ}\text{C}$	—	± 0.38	± 1.52	mV/ °C		
Shutdown output voltage	$V_{OUT/OFF}$	$V_{IN}=7\text{ V}$, $V_{PF}=\text{”L”}$, $R_L=1\text{ M}\Omega$	—	—	0.1	V	6	
Voltage Detector								
Operating voltage	V_{opr}	—	1.3	—	24	V	2	
Temperature characteristic of $-V_{DET}$	$\frac{\Delta -V_{DET}}{\Delta Ta}$	$Ta=-40^{\circ}\text{C to }+85^{\circ}\text{C}$	S-8750B0C	—	± 0.8	± 3.2	mV/ °C	2
			S-875077C	—	± 0.6	± 2.4		
			S-875061C to S-875037C, S-875037G	—	± 0.5	± 2.0		
Detection voltage	$-V_{DET}$	S-8750B0C	10.736	11.00	11.264	V		
		S-875077C	7.515	7.70	7.885			
		S-875061C	5.953	6.10	6.247			
		S-875045C	4.392	4.50	4.608			
		S-875043C	4.196	4.30	4.404			
		S-875041C	4.001	4.10	4.199			
		S-875039C	3.806	3.90	3.994			
		S-875037C/S-875037G	3.611	3.70	3.789			
Sink current	I_{DOUT}	Nch, $V_{DS}=0.5\text{ V}$	$V_{IN}=1.3\text{ V}$	0.25	0.60	—	mA	4
			$V_{IN}=2.4\text{ V}$	1.50	2.60	—		
			$V_{IN}=3.6\text{ V}$	3.00	4.50	—		
Leakage current	I_{LEAK}	Nch, $V_{DS}=24\text{ V}$	$V_{IN}=10\text{ V}$ S-875077C to S-875037C, S-875037G	—	—	0.1	μA	
			$V_{IN}=15\text{ V}$ S-8750B0C					
Hysteresis width	V_{HYS}	S-875045C	$-V_{DET}$ $\times 0.01$	—	$-V_{DET}$ $\times 0.025$	V	2	
		S-8750B0C to S-875061C, S-875043C to S-875037C, S-875037G	$-V_{DET}$ $\times 0.03$	—	$-V_{DET}$ $\times 0.08$			

Table 10 (2/2)

(Unless otherwise specified: Ta=25°C)

Item	Symbol	Condition	Min.	Typ.	Max.	Unit	Test circuit	
Input current								
Current consumption	I _{SS}	V _{IN} =7 V, Unloaded	S-8750B0C to S-875061C	—	4	8	μA	5
			S-875045C to S-875037C, S-875037G	—	3	8		
	I _{of}	V _{PF} ="L", Shutdown, V _{IN} =7 V	—	1.5	3.5			
Shutdown input voltage	V _{IL}	V _{PF} ="L", Shutdown, V _{IN} =7 V	—	—	0.4	V	6	
	V _{IH}	V _{PF} ="H", Power on, V _{IN} =7 V	2.0	—	—			

HIGH WITHSTAND-VOLTAGE VOLTAGE REGULATOR WITH RESET FUNCTION

Rev.7.1_00

S-87x Series

6. S-8730xxC Series

Table 11

(Unless otherwise specified: Ta=25°C)

Item	Symbol	Condition	Min.	Typ.	Max.	Unit	Test circuit	
Voltage Regulator								
Output voltage	V _{OUT}	V _{IN} =5 V, I _{OUT} =30 mA	2.928	3.000	3.072	V	1	
I/O voltage difference	V _{dif}	I _{OUT} =30 mA	—	0.45	0.70			
Line regulation	ΔV _{OUT1}	V _{IN} =4 to 24 V, I _{OUT} =30 mA	—	15	50	mV		
Load regulation	ΔV _{OUT2}	V _{IN} =5 V, I _{OUT} =50 μA to 40 mA	—	15	50			
Input voltage	V _{IN}	—	—	—	24	V		
Temperature coefficient of V _{OUT}	$\frac{\Delta V_{OUT}}{\Delta T_a}$	V _{IN} =5 V, I _{OUT} =30 mA, Ta=−40°C to +85°C	—	±0.23	±0.92	mV /°C		
Shutdown output voltage	V _{OUTOFF}	V _{IN} =5V, V _{PF} ="L", R _L =1 MΩ	—	—	0.1	V	6	
Voltage Detector								
Operating voltage	V _{opr}	—	1.3	—	24	V	2	
Temperature characteristic of −V _{DET}	$\frac{\Delta - V_{DET}}{\Delta T_a}$	Ta=−40°C to +85°C	S-873069C	—	±0.5	±2.0		mV /°C
			S-873025C to S-873021C	—	±0.3	±1.2		
Detection voltage	−V _{DET}	S-873069C	6.734	6.900	7.066	V		
		S-873025C	2.440	2.500	2.560			
		S-873024C	2.342	2.400	2.458			
		S-873023C	2.244	2.300	2.356			
		S-873022C	2.147	2.200	2.253			
		S-873021C	2.049	2.100	2.151			
Sink current	I _{DOUT}	Nch, V _{DS} =0.5 V	V _{IN} =1.3 V Other than below	0.25	0.60	—	mA	
			V _{IN} =2.4 V S-873069C, S-873025C	1.50	2.60	—		
			V _{IN} =3.6 V S-873069C	3.00	4.50	—		
Leakage current	I _{LEAK}	Nch, V _{DS} =24 V, V _{IN} =10 V	—	—	0.1	μA		
Hysteresis width	V _{HYS}	—	−V _{DET} ×0.03	—	−V _{DET} ×0.08	V	2	
Input current								
Current consumption	I _{SS}	V _{IN} =5 V, Unloaded	—	3	8	μA	5	
	I _{of}	V _{PF} ="L", Shutdown, V _{IN} =5 V	—	1.5	3.5			
Input Voltage								
Shutdown input voltage	V _{IL}	V _{PF} ="L", Shutdown, V _{IN} =5 V	—	—	0.4	V	6	
	V _{IH}	V _{PF} ="H", Power on, V _{IN} =5 V	2.0	—	—			

7. S-875271C, S-875255C

Table 12

(Unless otherwise specified: Ta=25°C)

Item	Symbol	Condition	Min.	Typ.	Max.	Unit	Test circuit	
Voltage Regulator								
Output voltage	V_{OUT}	$V_{IN}=7.2\text{ V}$, $I_{OUT}=30\text{ mA}$	5.075	5.20	5.325	V	1	
I/O voltage difference	V_{dif}	$I_{OUT}=30\text{ mA}$	—	0.15	0.40			
Line regulation	ΔV_{OUT1}	$V_{IN}=6.2\text{ to }24\text{ V}$, $I_{OUT}=30\text{ mA}$	—	15	50	mV		
Load regulation	ΔV_{OUT2}	$V_{IN}=7.2\text{ V}$, $I_{OUT}=50\text{ }\mu\text{A to }40\text{ mA}$	—	15	50			
Input voltage	V_{IN}	—	—	—	24	V		
Temperature coefficient of V_{OUT}	$\frac{\Delta V_{OUT}}{\Delta Ta}$	$V_{IN}=7.2\text{ V}$, $I_{OUT}=30\text{ mA}$, $Ta=-40^{\circ}\text{C to }+85^{\circ}\text{C}$	—	± 0.40	± 1.60	mV/ °C		
Shutdown output voltage	V_{OUTOFF}	$V_{IN}=7.2\text{ V}$, $\overline{V_{PF}}="L"$, $R_L=1\text{ M}\Omega$	—	—	0.1	V	6	
Voltage Detector								
Operating voltage	V_{opr}	—	1.3	—	24	V	2	
Temperature characteristic of $-V_{DET}$	$\frac{\Delta -V_{DET}}{\Delta Ta}$	$Ta=-40^{\circ}\text{C}$ to $+85^{\circ}\text{C}$	S-875271C	—	± 0.5	± 2.0		mV
			S-875255C	—	± 0.4	± 1.6		°C
Detection voltage	$-V_{DET}$	S-875271C	6.929	7.10	7.271	V		
		S-875255C	5.368	5.50	5.632			
Sink current	I_{DOUT}	Nch, $V_{DS}=0.5\text{ V}$	$V_{IN}=1.3\text{ V}$	0.25	0.60	—	mA	4
			$V_{IN}=2.4\text{ V}$	1.50	2.60	—		
			$V_{IN}=3.6\text{ V}$	3.00	4.50	—		
Leakage current	I_{LEAK}	Nch, $V_{DS}=24\text{ V}$, $V_{IN}=10\text{ V}$	—	—	0.1	μA		
Hysteresis width	V_{HYS}	—	$-V_{DET}$ $\times 0.03$	—	$-V_{DET}$ $\times 0.08$	V	2	
Input current								
Current consumption	I_{SS}	$V_{IN}=7.2\text{ V}$, Unloaded	—	4	8	μA	5	
	I_{of}	$\overline{V_{PF}}="L"$, Shutdown, $V_{IN}=7.2\text{ V}$	—	1.5	3.5			
Input Voltage								
Shutdown input voltage	V_{IL}	$\overline{V_{PF}}="L"$, Shutdown, $V_{IN}=7.2\text{ V}$	—	—	0.4	V	6	
	V_{IH}	$\overline{V_{PF}}="H"$, Power on, $V_{IN}=7.2\text{ V}$	2.0	—	—			

HIGH WITHSTAND-VOLTAGE VOLTAGE REGULATOR WITH RESET FUNCTION

Rev.7.1_00

S-87x Series

8. S-875294C

Table 13

(Unless otherwise specified: Ta=25°C)

Item	Symbol	Condition	Min.	Typ.	Max.	Unit	Test circuit	
Voltage Regulator								
Output voltage	V_{OUT}	$V_{IN}=14.4\text{ V}$, $I_{OUT}=30\text{ mA}$	5.075	5.20	5.325	V	1	
I/O voltage difference	V_{dif}	$I_{OUT}=30\text{ mA}$	—	0.15	0.40			
Line regulation	ΔV_{OUT1}	$V_{IN}=6.2\text{ to }24\text{ V}$, $I_{OUT}=30\text{ mA}$	—	15	50	mV		
Load regulation	ΔV_{OUT2}	$V_{IN}=14.4\text{ V}$, $I_{OUT}=50\text{ }\mu\text{A to }40\text{ mA}$	—	15	50			
Input voltage	V_{IN}	—	—	—	24	V		
Temperature coefficient of V_{OUT}	$\frac{\Delta V_{OUT}}{\Delta Ta}$	$V_{IN}=14.4\text{ V}$, $I_{OUT}=30\text{ mA}$, $Ta=-40^{\circ}\text{C to }+85^{\circ}\text{C}$	—	± 0.40	± 1.60	mV/ °C		
Shutdown output voltage	V_{OUTOFF}	$V_{IN}=14.4\text{ V}$, $\overline{V_{PF}}="L"$, $R_L=1\text{ M}\Omega$	—	—	0.1	V	6	
Voltage Detector								
Operating voltage	V_{opr}	—	1.3	—	24	V	2	
Temperature characteristic of $-V_{DET}$	$\frac{\Delta -V_{DET}}{\Delta Ta}$	$Ta=-40^{\circ}\text{C to }+85^{\circ}\text{C}$	—	± 0.7	± 2.8	mV/ °C		
Detection voltage	$-V_{DET}$	—	9.174	9.40	9.626	V		
Sink current	I_{DOUT}	Nch, $V_{DS}=0.5\text{ V}$	$V_{IN}=1.3\text{ V}$	0.25	0.60	—	mA	4
			$V_{IN}=2.4\text{ V}$	1.50	2.60	—		
			$V_{IN}=3.6\text{ V}$	3.00	4.50	—		
Leakage current	I_{LEAK}	Nch, $V_{DS}=24\text{ V}$, $V_{IN}=10\text{ V}$	—	—	0.1	μA		
Hysteresis width	V_{HYS}	—	$-V_{DET}$ $\times 0.03$	—	$-V_{DET}$ $\times 0.08$	V	2	
Input current								
Current consumption	I_{SS}	$V_{IN}=14.4\text{ V}$, Unloaded	—	4	9	μA	5	
	I_{of}	$\overline{V_{PF}}="L"$, Shutdown,, $V_{IN}=14.4\text{ V}$	—	2.1	4.7			
Input Voltage								
Shutdown input voltage	V_{IL}	$\overline{V_{PF}}="L"$, Shutdown, $V_{IN}=14.4\text{ V}$	—	—	0.4	V	6	
	V_{IH}	$\overline{V_{PF}}="H"$, Power on, $V_{IN}=14.4\text{ V}$	2.6	—	—			

9. S-873361C

Table 14

(Unless otherwise specified: Ta=25°C)

Item	Symbol	Condition	Min.	Typ.	Max.	Unit	Test circuit	
Voltage Regulator								
Output voltage	V_{OUT}	$V_{IN}=5.3\text{ V}$, $I_{OUT}=30\text{ mA}$	3.220	3.300	3.380	V	1	
I/O voltage difference	V_{dif}	$I_{OUT}=30\text{ mA}$	—	0.45	0.70			
Line regulation	ΔV_{OUT1}	$V_{IN}=4.3\text{ to }24\text{ V}$, $I_{OUT}=30\text{ mA}$	—	15	50	mV		
Load regulation	ΔV_{OUT2}	$V_{IN}=5.3\text{ V}$, $I_{OUT}=50\text{ }\mu\text{A to }40\text{ mA}$	—	15	50			
Input voltage	V_{IN}	—	—	—	24	V		
Temperature coefficient of V_{OUT}	$\frac{\Delta V_{OUT}}{\Delta Ta}$	$V_{IN}=5.3\text{ V}$, $I_{OUT}=30\text{ mA}$, $Ta=-40^{\circ}\text{C to }+85^{\circ}\text{C}$	—	± 0.25	± 1.00	mV/ $^{\circ}\text{C}$		
Shutdown output voltage	V_{OUTOFF}	$V_{IN}=5.3\text{ V}$, $\overline{V_{PF}}="L"$, $R_L=1\text{ M}\Omega$	—	—	0.1	V	6	
Voltage Detector								
Operating voltage	V_{opr}	—	1.3	—	24	V	2	
Temperature characteristic of $-V_{DET}$	$\frac{\Delta -V_{DET}}{\Delta Ta}$	$Ta=-40^{\circ}\text{C to }+85^{\circ}\text{C}$	—	± 0.5	± 2.0	mV/ $^{\circ}\text{C}$		
Detection voltage	$-V_{DET}$	—	5.953	6.100	6.247	V		
Sink current	I_{DOUT}	Nch, $V_{DS}=0.5\text{ V}$	$V_{IN}=1.3\text{ V}$ $V_{IN}=2.4\text{ V}$ $V_{IN}=3.6\text{ V}$	0.25 1.50 3.00	0.60 2.60 4.50	— — —	mA	4
Leakage current	I_{LEAK}	Nch, $V_{DS}=24\text{ V}$, $V_{IN}=10\text{ V}$	—	—	0.1	μA		
Hysteresis width	V_{HYS}	—	$-V_{DET}$ $\times 0.03$	—	$-V_{DET}$ $\times 0.08$	V	2	
Input current								
Current consumption	I_{SS}	$V_{IN}=5.3\text{ V}$, Unloaded	—	4	8	μA	5	
	I_{of}	$\overline{V_{PF}}="L"$, Shutdown, $V_{IN}=5.3\text{ V}$	—	1.5	3.5			
Input Voltage								
Shutdown input voltage	V_{IL}	$\overline{V_{PF}}="L"$, Shutdown, $V_{IN}=5.3\text{ V}$	—	—	0.4	V	6	
	V_{IH}	$\overline{V_{PF}}="H"$, Power on, $V_{IN}=5.3\text{ V}$	2.0	—	—			

HIGH WITHSTAND-VOLTAGE VOLTAGE REGULATOR WITH RESET FUNCTION

Rev.7.1_00

S-87x Series

10. S-8750xxE Series

Table 15

(Unless otherwise specified: Ta=25°C, Connect the SENSE pin to the VIN pin.)

Item	Symbol	Condition	Min.	Typ.	Max.	Unit	Test circuit
Voltage Regulator							
Output voltage	V _{OUT}	V _{IN} =7 V, I _{OUT} =30 mA, V _{SENSE} =-V _{DET (Typ.)} +2 V	4.88	5.00	5.12	V	1
I/O voltage difference	V _{dif}	I _{OUT} =30 mA, V _{SENSE} =-V _{DET (Typ.)} +2 V	—	0.15	0.40		
Line regulation	ΔV _{OUT1}	V _{IN} =6 to 24 V, I _{OUT} =30 mA, V _{SENSE} =-V _{DET (Typ.)} +2 V	—	15	50	mV	
Load regulation	ΔV _{OUT2}	V _{IN} =7 V, I _{OUT} =50 μA to 40 mA, V _{SENSE} =-V _{DET (Typ.)} +2 V	—	15	50		
Input voltage	V _{IN}	—	—	—	24	V	
Temperature coefficient of V _{OUT}	$\frac{\Delta V_{OUT}}{\Delta Ta}$	V _{IN} =7 V, I _{OUT} =30 mA, Ta=-40°C to +85°C, V _{SENSE} =-V _{DET (Typ.)} +2 V	—	±0.38	±1.52	mV/°C	
Output voltage during voltage detection	V _{OUTOFF}	V _{IN} =-V _{DET (Typ.)} -1V, R _L =1 MΩ	—	—	0.1	V	6
Voltage Detector							
Operating voltage	V _{opr}	—	1.3	—	24	V	2
Temperature characteristic of -V _{DET}	$\frac{\Delta - V_{DET}}{\Delta Ta}$	Ta=-40°C to +85°C	S-875077E	—	±0.6	±2.4	mV/°C
			S-875061E		±0.5	±2.0	
Detection voltage	-V _{DET}	Nch, V _{DS} =0.5 V	S-875077E	7.515	7.70	7.885	V
			S-875061E	5.953	6.10	6.247	
Sink current	I _{DOUT}	Nch, V _{DS} =0.5 V	V _{IN} =1.3 V	0.25	0.60	—	mA
			V _{IN} =2.4 V	1.50	2.60	—	
			V _{IN} =3.6 V	3.00	4.50	—	
Leakage current	I _{LEAK}	Nch, V _{DS} =24 V, V _{IN} =-V _{DET (Typ.)} +2 V	—	—	0.1	μA	
SENSE pin input current	I _{SENSE}	V _{IN} =7 V, V _{SENSE} =-V _{DET (Typ.)} +2 V	S-875077E	—	0.6	1.7	7
			S-875061E	—	0.7	1.8	
Hysteresis width	V _{HYS}	—	-V _{DET} ×0.03	—	-V _{DET} ×0.08	V	2
Input current							
Current consumption	I _{SS}	V _{IN} =-V _{DET (Typ.)} +2 V, Unloaded	S-875077E	—	4	8	μA
			S-875061E	—	4	9	
	I _{of}	V _{IN} =-V _{DET (Typ.)} -1 V, Shutdown	—	1.5	3.5		

HIGH WITHSTAND-VOLTAGE VOLTAGE REGULATOR WITH RESET FUNCTION

S-87x Series

Rev.7.1_00

11. S-8730xxE Series

Table 16

(Unless otherwise specified: Ta=25°C, Connect the SENSE pin to the VIN pin.)

Item	Symbol	Condition	Min.	Typ.	Max.	Unit	Test circuit	
Voltage Regulator								
Output voltage	V_{OUT}	$V_{IN}=5\text{ V}$, $I_{OUT}=30\text{ mA}$, $V_{SENSE}=-V_{DET(TYP.)}+2\text{ V}$	2.928	3.000	3.072	V	1	
I/O voltage difference	V_{dif}	$I_{OUT}=30\text{ mA}$, $V_{SENSE}=-V_{DET(TYP.)}+2\text{ V}$	—	0.45	0.70			
Line regulation	ΔV_{OUT1}	$V_{IN}=4\text{ to }24\text{ V}$, $I_{OUT}=30\text{ mA}$, $V_{SENSE}=-V_{DET(TYP.)}+2\text{ V}$	—	15	50	mV		
Load regulation	ΔV_{OUT2}	$V_{IN}=5\text{ V}$, $I_{OUT}=50\text{ }\mu\text{A to }40\text{ mA}$, $V_{SENSE}=-V_{DET(TYP.)}+2\text{ V}$	—	15	50			
Input voltage	V_{IN}	—	—	—	24	V		
Temperature coefficient of V_{OUT}	$\frac{\Delta V_{OUT}}{\Delta Ta}$	$V_{IN}=5\text{ V}$, $I_{OUT}=30\text{ mA}$, $Ta=-40^{\circ}\text{C to }+85^{\circ}\text{C}$, $V_{SENSE}=-V_{DET(TYP.)}+2\text{ V}$	—	± 0.23	± 0.92	mV/ °C		
Output voltage during voltage detection	V_{OUTOFF}	$V_{IN}=-V_{DET(TYP.)}-1\text{ V}$, $R_L=1\text{ M}\Omega$	—	—	0.1	V	6	
Voltage Detector								
Operating voltage	V_{opr}	—	1.3	—	24	V	2	
Temperature characteristic of $-V_{DET}$	$\frac{\Delta -V_{DET}}{\Delta Ta}$	$Ta=-40^{\circ}\text{C to }+85^{\circ}\text{C}$	S-873082E	—	± 0.6	± 2.4		mV/ °C
			S-873062E	—	± 0.5	± 2.0		
Detection voltage	$-V_{DET}$	S-873082E	8.003	8.200	8.397	V		
		S-873062E	6.051	6.200	6.349			
Sink current	I_{DOUT}	Nch, $V_{DS}=0.5\text{ V}$	$V_{IN}=1.3\text{ V}$	0.25	0.60	—	mA	
			$V_{IN}=2.4\text{ V}$	1.50	2.60	—		
			$V_{IN}=3.6\text{ V}$	3.00	4.50	—		
Leakage current	I_{LEAK}	Nch, $V_{DS}=24\text{ V}$, $V_{IN}=-V_{DET(TYP.)}+2\text{ V}$	—	—	0.1	μA	7	
SENSE pin input current	I_{SENSE}	$V_{IN}=5\text{ V}$, $V_{SENSE}=-V_{DET(TYP.)}+2\text{ V}$	S-873082E	—	0.6	1.7		
			S-873062E	—	0.6	1.8		
Hysteresis width	V_{HYS}	—	$-V_{DET} \times 0.03$	—	$-V_{DET} \times 0.08$	V	2	
Input current								
Current consumption	I_{SS}	$V_{IN}=-V_{DET(TYP.)}+2\text{ V}$, Unloaded	—	4	8	μA	5	
	I_{of}	$V_{IN}=-V_{DET(TYP.)}-1\text{ V}$, Shutdown	—	1.5	3.5			

HIGH WITHSTAND-VOLTAGE VOLTAGE REGULATOR WITH RESET FUNCTION

Rev.7.1_00

S-87x Series

12. S-873330E

Table 17

(Unless otherwise specified: Ta=25°C, Connect the SENSE pin to the VIN pin.)

Item	Symbol	Condition	Min.	Typ.	Max.	Unit	Test circuit	
Voltage Regulator								
Output voltage	V _{OUT}	V _{IN} =5.3 V, I _{OUT} =30 mA, V _{SENSE} =-V _{DET (Typ.)} +2 V	3.220	3.300	3.380	V	1	
I/O voltage difference	V _{dif}	I _{OUT} =30 mA, V _{SENSE} =-V _{DET (Typ.)} +2 V	—	0.45	0.70			
Line regulation	ΔV _{OUT1}	V _{IN} =4.3 to 24 V, I _{OUT} =30 mA, V _{SENSE} =-V _{DET (Typ.)} +2 V	—	15	50	mV		
Load regulation	ΔV _{OUT2}	V _{IN} =5.3 V, I _{OUT} =50 μA to 40 mA, V _{SENSE} =-V _{DET (Typ.)} +2 V	—	15	50			
Input voltage	V _{IN}	—	—	—	24	V		
Temperature coefficient of V _{OUT}	$\frac{\Delta V_{OUT}}{\Delta T_a}$	V _{IN} =5.3 V, I _{OUT} =30 mA, Ta=-40°C to +85°C, V _{SENSE} =-V _{DET (Typ.)} +2 V	—	±0.25	±1.00	mV/°C		
Output voltage during voltage detection	V _{OUTOFF}	V _{IN} =-V _{DET (Typ.)} -1 V, R _L =1 MΩ	—	—	0.1	V	6	
Voltage Detector								
Operating voltage	V _{OPR}	—	1.3	—	24	V	2	
Temperature characteristic of -V _{DET}	$\frac{\Delta -V_{DET}}{\Delta T_a}$	Ta=-40°C to +85°C	—	±0.2	±0.8	mV/°C		
Detection voltage	-V _{DET}	—	2.928	3.000	3.072	V		
Sink current	I _{DOUT}	Nch, V _{DS} =0.5 V	V _{IN} =1.3 V	0.25	0.60	—	mA	4
			V _{IN} =2.4 V	1.50	2.60	—		
Leakage current	I _{LEAK}	Nch, V _{DS} =24 V, V _{IN} =-V _{DET (Typ.)} +2 V	—	—	0.1	μA		
SENSE pin input current	I _{SENSE}	V _{IN} =5.3 V, V _{SENSE} =-V _{DET (Typ.)} +2 V	—	0.5	1.3		7	
Hysteresis width	V _{HYS}	—	-V _{DET} ×0.03	—	-V _{DET} ×0.08	V	2	
Input current								
Current consumption	I _{SS}	V _{IN} =-V _{DET (Typ.)} +2 V, Unloaded	—	4	8	μA	5	
	I _{of}	V _{IN} =-V _{DET (Typ.)} -1 V, Shutdown	—	1.5	3.5			

HIGH WITHSTAND-VOLTAGE VOLTAGE REGULATOR WITH RESET FUNCTION

S-87x Series

Rev.7.1_00

13. S-8725xxE Series

Table 18

(Unless otherwise specified: Ta=25°C, Connect the SENSE pin to the VIN pin.)

Item	Symbol	Condition	Min.	Typ.	Max.	Unit	Test circuit
Voltage Regulator							
Output voltage	V_{OUT}	$V_{IN}=4.5\text{ V}$, $I_{OUT}=30\text{ mA}$, $V_{SENSE}=-V_{DET(TYP.)}+2\text{ V}$	2.440	2.500	2.560	V	1
I/O voltage difference	V_{dif}	$I_{OUT}=30\text{ mA}$, $V_{SENSE}=-V_{DET(TYP.)}+2\text{ V}$	—	0.65	1.00		
Line regulation	ΔV_{OUT1}	$V_{IN}=4.5\text{ to }24\text{ V}$, $I_{OUT}=30\text{ mA}$, $V_{SENSE}=-V_{DET(TYP.)}+2\text{ V}$	—	15	50	mV	
Load regulation	ΔV_{OUT2}	$V_{IN}=4.5\text{ V}$, $I_{OUT}=50\text{ }\mu\text{A to }40\text{ mA}$, $V_{SENSE}=-V_{DET(TYP.)}+2\text{ V}$	—	15	50		
Input voltage	V_{IN}	—	—	—	24	V	
Temperature coefficient of V_{OUT}	$\frac{\Delta V_{OUT}}{\Delta Ta}$	$V_{IN}=4.5\text{ V}$, $I_{OUT}=30\text{ mA}$, $Ta=-40^{\circ}\text{C to }+85^{\circ}\text{C}$, $V_{SENSE}=-V_{DET(TYP.)}+2\text{ V}$	—	± 0.23	± 0.92	mV/ °C	
Output voltage during voltage detection	V_{OUTOFF}	$V_{IN}=-V_{DET(TYP.)}-1\text{ V}$, $R_L=1\text{ M}\Omega$	—	—	0.1	V	6
Voltage Detector							
Operating voltage	V_{OPR}	—	1.3	—	24	V	2
Temperature characteristic of $-V_{DET}$	$\frac{\Delta -V_{DET}}{\Delta Ta}$	$Ta=-40^{\circ}\text{C to }+85^{\circ}\text{C}$	S-872548E —	± 0.5	± 2.0	mV/ °C	
			S-872530E to S-872526E —	± 0.2	± 0.8		
Detection voltage	$-V_{DET}$	S-872548E	4.685	4.800	4.915	V	
		S-872530E	2.928	3.000	3.072		
		S-872526E	2.538	2.600	2.662		
Sink current	I_{DOUT}	Nch, $V_{DS}=0.5\text{ V}$	$V_{IN}=1.3\text{ V}$ 0.25	0.60	—	mA	4
			$V_{IN}=2.4\text{ V}$ 1.50	2.60	—		
			$V_{IN}=3.6\text{ V}$ 3.00	4.50	—		
Leakage current	I_{LEAK}	Nch, $V_{DS}=24\text{ V}$, $V_{IN}=-V_{DET(TYP.)}+2\text{ V}$	—	—	0.1	μA	
SENSE pin input current	I_{SENSE}	$V_{IN}=4.5\text{ V}$, $V_{SENSE}=-V_{DET(TYP.)}+2\text{ V}$	—	0.5	1.3		7
Hysteresis width	V_{HYS}	S-872548E to S-872530E	$-V_{DET}$ $\times 0.03$	—	$-V_{DET}$ $\times 0.08$	V	2
		S-872526E	$-V_{DET}$ $\times 0.02$	—	$-V_{DET}$ $\times 0.05$		
Input current							
Current consumption	I_{SS}	$V_{IN}=-V_{DET(TYP.)}+2\text{ V}$, Unloaded	—	4	8	μA	5
	I_{of}	$V_{IN}=-V_{DET(TYP.)}-1\text{ V}$, Shutdown	—	1.5	3.5		

HIGH WITHSTAND-VOLTAGE VOLTAGE REGULATOR WITH RESET FUNCTION

Rev.7.1_00

S-87x Series

14. S-875087F

Table 19

(Unless otherwise specified: Ta=25°C)

Item	Symbol	Condition	Min.	Typ.	Max.	Unit	Test circuit	
Voltage Regulator								
Output voltage	V_{OUT}	$V_{IN}=7\text{ V}$, $I_{OUT}=30\text{ mA}$	4.88	5.00	5.12	V	1	
I/O voltage difference	V_{dif}	$I_{OUT}=30\text{ mA}$	—	0.15	0.40			
Line regulation	ΔV_{OUT1}	$V_{IN}=6\text{ to }24\text{ V}$, $I_{OUT}=30\text{ mA}$	—	15	50	mV		
Load regulation	ΔV_{OUT2}	$V_{IN}=7\text{ V}$, $I_{OUT}=50\text{ }\mu\text{A to }40\text{ mA}$	—	15	50			
Input voltage	V_{IN}	—	—	—	24	V		
Temperature coefficient of V_{OUT}	$\frac{\Delta V_{OUT}}{\Delta Ta}$	$V_{IN}=7\text{ V}$, $I_{OUT}=30\text{ mA}$, $Ta=-40^\circ\text{C to }+85^\circ\text{C}$	—	± 0.38	± 1.52	mV/ °C		
Voltage Detector								
Operating voltage	V_{opr}	—	1.3	—	24	V	2	
Delay time*1	t_{pd}	$C_D=4.7\text{ nF}$	15	27	41	ms	3	
Release voltage vs Temperature	$\frac{\Delta +V_{DET}}{\Delta Ta}$	$Ta=-40^\circ\text{C to }+85^\circ\text{C}$	—	± 0.7	± 2.8	mV/ °C	2	
Release voltage (Overcharge detection voltage)	$+V_{DET}$	—	8.600	8.700	8.800	V		
Sink current	I_{DOUT}	Nch, $V_{DS}=0.5\text{ V}$	$V_{IN}=1.3\text{ V}$	0.25	0.60	—	mA	4
			$V_{IN}=2.4\text{ V}$	1.50	2.60	—		
			$V_{IN}=3.6\text{ V}$	3.00	4.50	—		
Leakage current	I_{LEAK}	Nch, $V_{DS}=24\text{ V}$, $V_{IN}=15\text{ V}$	—	—	0.1	μA		
Hysteresis width	V_{HYS}	—	0.085	—	0.215	V	2	
Input current								
Current consumption*2	I_{SS}	$V_{IN}=7\text{ V}$, Unloaded	—	4	8	μA	5	

*1. $t_{pd}\text{ (ms)}=(3.18\text{min.}, 5.74\text{typ.}, 8.73\text{max.})\times C_D\text{(nF)}$

*2. Excluding the charging current of C_D .

■ **Measurement Circuits**

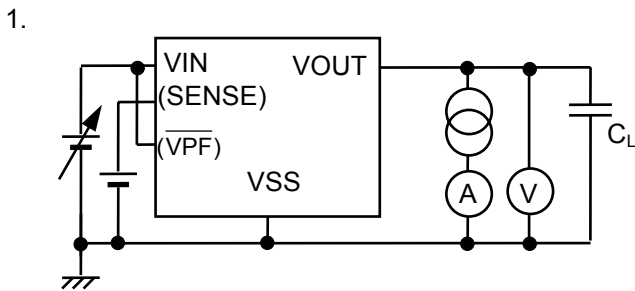

Figure 7

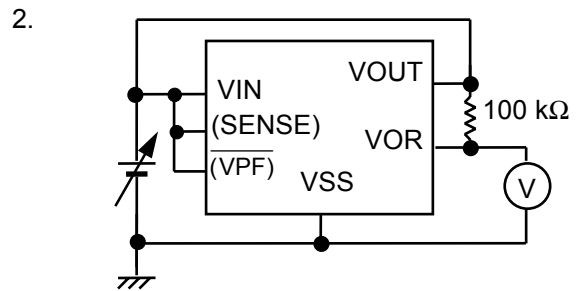

Figure 8

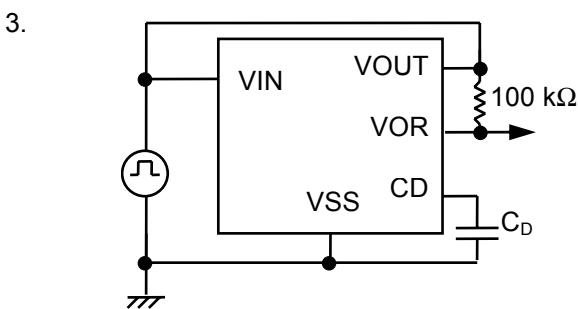

Figure 9

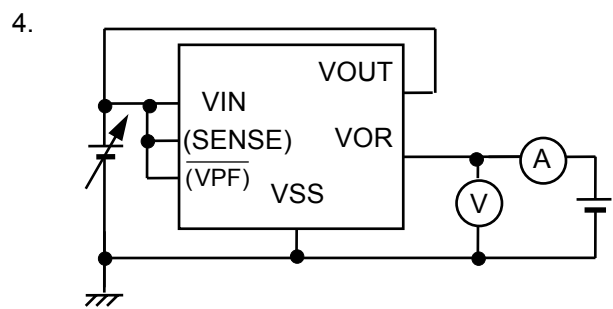

Figure 10

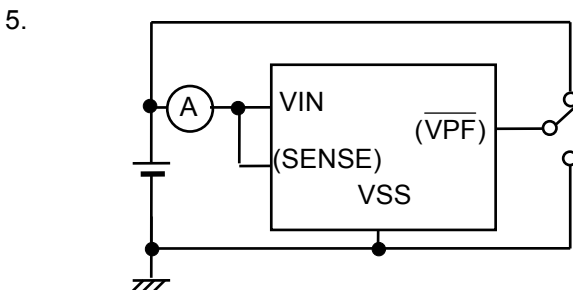

Figure 11

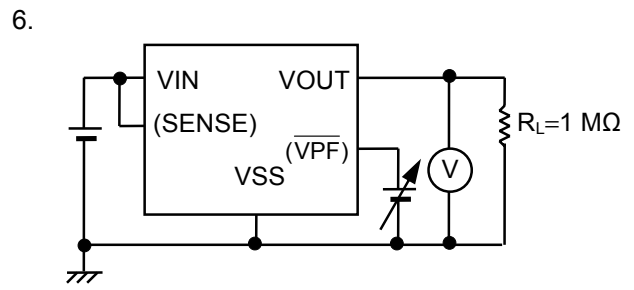

Figure 12

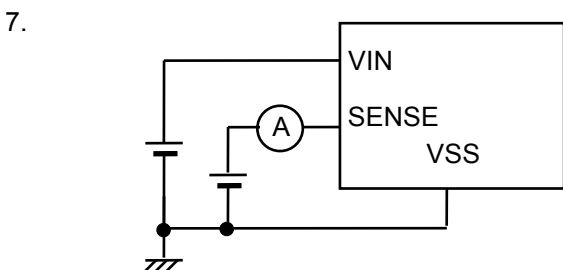
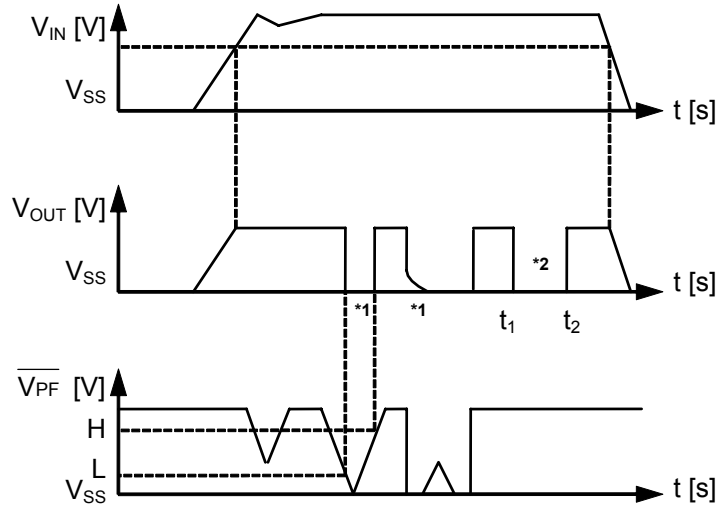

Figure 13

■ Operation Timing Charts

1. Voltage regulator (C/G type)



- *1. Indicates shutdown state. When the load current (I_{OUT}) is less than $1 \mu A$, the output voltage (V_{OUT}) is not always V_{SS} level.
- *2. When the V_{OUT} is shorted at t_1 , V_{OUT} becomes V_{SS} level. When the short of V_{OUT} is removed at t_2 , V_{OUT} returns to normal output.

Figure 14

2. Voltage detector (A/B/F type)

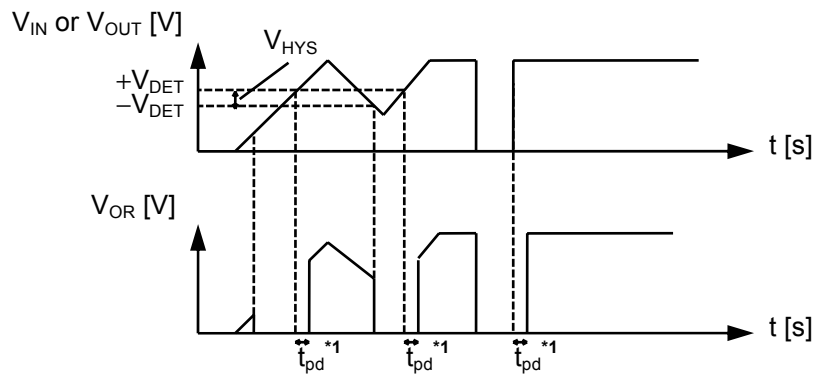

- *1. Output delay time (t_{pd}) of the voltage detector can be changed with an external capacitance value to CD pin. Delay circuit is not included in C/E/G type.

Remark Pull up V_{OR} through a resistor to V_{IN} or V_{OUT} .

Figure 15

3. When using the SENSE pin (E type)

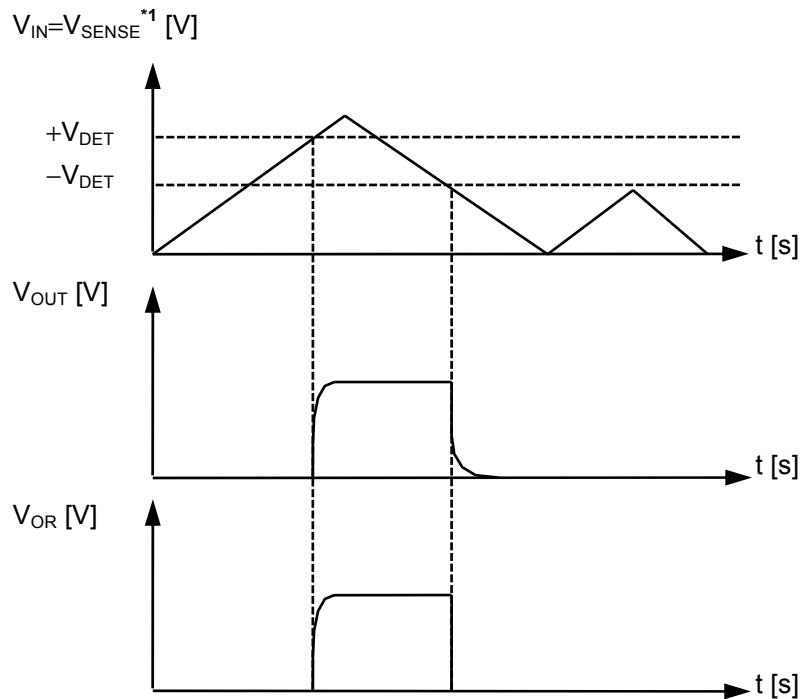

*1. The SENSE pin is connected to VIN pin.

Remark Pull up V_{OR} through a resistor to V_{OUT} .

Figure 16

■ Explanation of Terms

1. I/O voltage difference (V_{dif})

$$V_{dif}=V_{IN1}-V_{OUT1}$$

V_{OUT1} : Initial output voltage

V_{IN1} : Input voltage which generates an output voltage (V_{OUT2}) decreased by 5 % from V_{OUT1}

2. Load regulation (ΔV_{OUT2})

$$\Delta V_{OUT2}=V_{OUT1}-V_{OUT2}$$

V_{OUT1} : Output voltage when I_{OUT} is 50 μA

V_{OUT2} : Output voltage when I_{OUT} is 40 mA

3. Line regulation (ΔV_{OUT1})

$$\Delta V_{OUT1}=V_{OUT1}-V_{OUT2}$$

V_{OUT1} : Output voltage when V_{IN} is 24 V

V_{OUT2} : Output voltage when V_{IN} is ($V_{OUT1}+1$) V

4. Hysteresis width (V_{HYS})

$$V_{HYS}=(+V_{DET})-(-V_{DET})$$

$+V_{DET}$: Release voltage

$-V_{DET}$: Detection voltage

■ Operation

1. Reference voltage circuit

The reference voltage circuit operates all the time when the voltage is applied to VIN pin and is not affected by the $\overline{V_{PF}}$ signal.

2. Voltage regulator

Figure 17 shows the voltage regulator circuit. The S-87x Series has a Pch MOS transistor as the output control transistor.

Reverse current may break IC if VOUT potential is higher than VIN, because a parasitic diode is formed between VIN and VOUT due to the structure of the control transistor. Therefore, keep VOUT lower than VIN+0.3 V.

The output voltage of the voltage regulator can be selected as follows:
2.5 V to 5.8 V±2.4 % (0.1 V step)

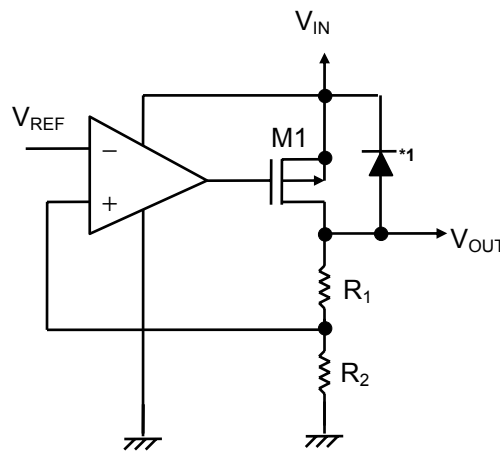

*1. Parasitic diode

Figure 17 Voltage regulator circuit

Caution For an application with a load current of less than 1 μA, the leakage current of the control transistor M1 increases the output voltage.

3. Short-circuit protection circuit

The S-87x Series has a built-in short-circuit protection circuit to protect the element from break caused by a large current in case of a short circuit. The output short current is internally limited to approx. 70 mA. Short-circuit protection circuit has three kinds characteristics according to input voltage (VIN) as shown in Figure 18 to 20.

At 5 V Output:

(a) $V_{IN}/V_{OUT} \geq 2.0$

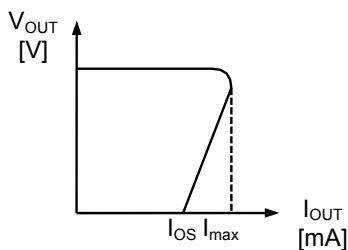

Figure 18

(b) $1.5 \leq V_{IN}/V_{OUT} < 2.0$

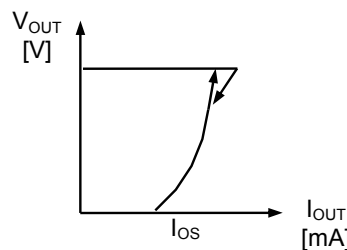

Figure 19

(c) $V_{IN}/V_{OUT} < 1.5$

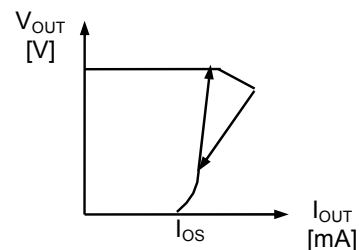

Figure 20

4. Delay circuit

The delay circuit outputs voltage detector output (V_{OR}) with delay after the voltage at V_{IN} pin has become release voltage ($+V_{DET}$) at the rising of V_{IN} pin.

In **Figure 21**, when V_{cd} exceeds the reference voltage (V_{ref}), the output voltage pin detection voltage output (V_{OR}) changes from low to high level, providing delay output. When the voltage at V_{IN} pin falls under the detection voltage ($-V_{DET}$), the N2 transistor turns ON, therefore the charge of the external capacitor (C_D) is rapidly discharged and the voltage detector output (V_{OR}) changes from high to low level without delay.

The external capacitor (C_D) is charged with constant current, and is practically independent of V_{IN} voltage. Its delay time (t_{pd}) is expressed by the following equation:

$$t_{pd} \text{ (ms)} = \text{Delay coefficient (3.18 min., 5.74 typ., 8.73 max.)} \times C_D \text{ (nF)}$$

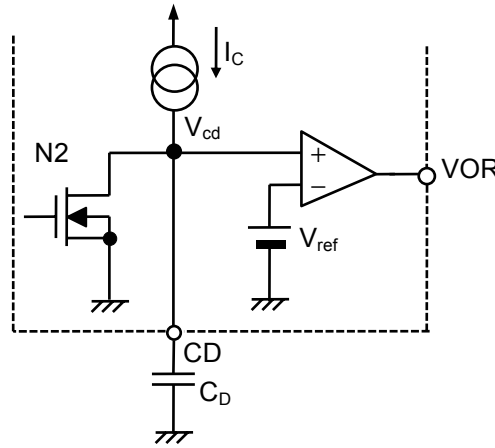

Figure 21

- Caution 1.** Unless an output delay is needed, keep CD pin open. Do not apply external voltage other than ground potential to CD pin, which may cause IC breakdown.
- 2.** When designing your printed-circuit board layout, take care that no leakage current flows to the external capacitor (C_D), otherwise the correct delay time may not be obtained. Because the value of the constant current source (I_C) is only 195 nA, C_D impedance is high.

5. Voltage detection circuit

The built-in voltage detection circuit (Nch opendrain type) is equivalent to our S-808 Series/S-809 Series voltage detectors. A pull-up resistor of about 100 kΩ is required for output. Since the comparator power of this circuit is supplied from VIN pin, this circuit operates while voltage is applied to VIN pin.

The detection voltage of the voltage detector can be selected as follows:

2.1 V to 11.3 V ± 2.4 % (0.1 V step)

In the F type, the release voltage (+V_{DET}) accuracy is ±1.1 %. So, it responds to the application for overcharge detection of lithium-ion battery packs.

In the E type, the input voltage monitoring pin of the voltage detector is externally connected as the SENSE pin. Because this pin is configured by a resistor only, temporary current such as a through-type current does not flow. Consequently even when resistor (R_{IN}) is inserted between input power supply and VIN pin, the input power voltage can be accurately monitored by connecting the SENSE pin to the input power supply. Also, when a drop in the SENSE pin input voltage is detected, the voltage detector generates a reset signal. At the same time, it powers off the voltage regulator.

Caution 1. As shown in Figure 22 to 24, when connecting V_{OR} output to $\overline{\text{VPF}}$ pin in the C type or connecting SENSE pin to VIN pin in the E type, the following phenomena occur if resistor (R_{IN}) is connected between input voltage and VIN pin. Be careful.

- (1) At the time of voltage detection, the voltage regulator is shutdown and load current is cut. Therefore, VIN pin voltage increases by $\Delta V_{IN} = I_{IN} \times R_{IN}$, where the current flowing into R_{IN} is set to I_{IN}. Hence, if ΔV_{IN} exceeds hysteresis width (V_{HYS}), oscillation starts immediately after detection and continues. It is necessary to set ΔV_{IN} less than V_{HYS}.
- (2) At the time of voltage release, the voltage regulator is powered on and load current flows. Therefore, if ΔV_{IN} exceeds hysteresis width (V_{HYS}), oscillation starts immediately after release and continues. It is necessary to set ΔV_{IN} less than V_{HYS}. Also at the time of voltage release, the rush current to charge output capacitor (C_{OUT}) flows. Hence, oscillation momentarily starts until the output of regulator (V_{OUT}) rises high enough even though ΔV_{IN} is set less than V_{HYS}. But Short-circuit protection circuit controls the rush current less than I_{MAX} on Figure 18 to 20. If this momentary oscillation is a problem in your application, setting R_{IN} less than V_{HYS}/I_{MAX} prevents oscillation.

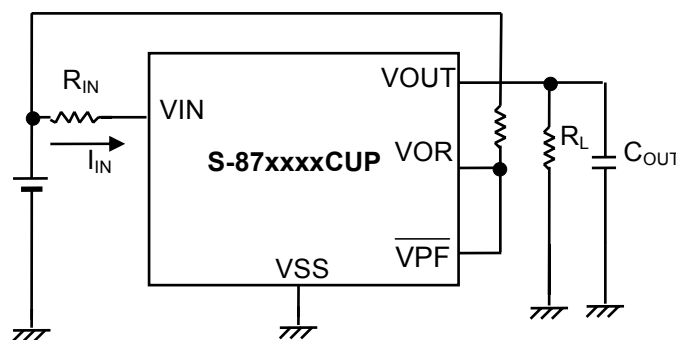

Figure 22 Attention connecting example 1

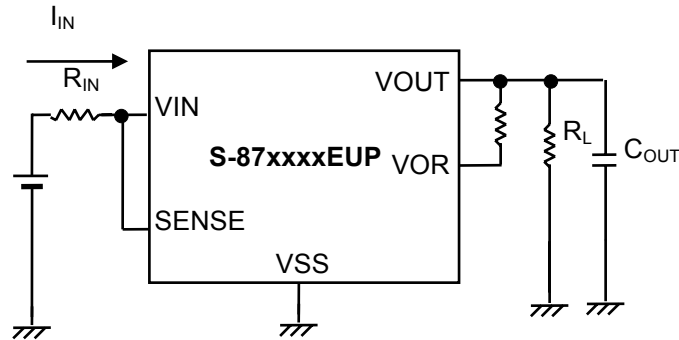

Figure 23 Attention connecting example 2

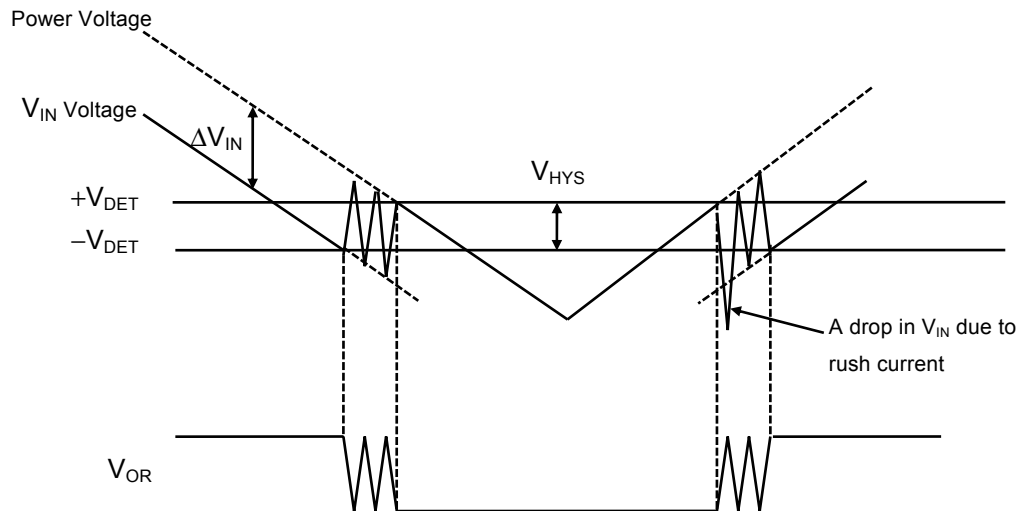

Figure 24 When $\Delta V_{IN} > V_{HYS}$

2. In the E type, the minimum operating voltage becomes 2.0 V as V_{IN} voltage. If a drop in V_{IN} voltage occurs due to load current or rush current to be charged to the output capacitor when load current or the voltage regulator is powered on at the time of release, set V_{IN} to 2.0 V or more.
3. Also, in the E type, when sharply increasing only V_{IN} pin voltage at 1 ms/V or less, with the SENSE pin fixed to $-V_{DET} \geq V_{SENSE} \geq -V_{DET} - 2V$, a release pulse is output to the output pin of voltage detector. Be careful. In this case, this release pulse is removed by setting the time constant of VOR pin 20 ms or more with capacitance and pull-up resistance. In addition, when the voltage of SENSE pin is fixed to between the detection voltage and the release voltage at the detect condition, if sharply increasing only V_{IN} pin voltage at 1 ms/V or less, the output of the detector turns to the release condition. If this action is a problem in your system, please connect SENSE pin to V_{IN} pin.

6. Shutdown circuit (C/E/G type)

When $\overline{\text{VPF}}$ pin goes low (0.4 V or less) in the C/G type or at the time of voltage detection in the E type current for the voltage regulator is shut down, the current consumption (excluding the current which flows through the pull-up resistor) lowers to 3.5 μA or less.

During shutdown, the M1 transistor in the voltage regulator shown in the **Figure 16** is off and VOUT pin is pulled down by R_1 and R_2 , whose value (R_1+R_2) is 5 M Ω to 10 M Ω . Input current of $\overline{\text{VPF}}$ pin is 0.1 μA or less.

- Caution**
1. The output voltage may not become 0 V when the load which makes I_{OUT} under 1 μA is connected during shutdown.
 2. DO NOT keep $\overline{\text{VPF}}$ pin floating state or medium potential (between low and high levels). Otherwise through-type current flows.

■ **Transient Characteristics**

An undershoot or an overshoot may occur in the output voltage of the voltage regulator if input voltage or load current fluctuates transiently. If an undershoot is large, the voltage detector operates to output reset signal in the B type in which the voltage detector detects the output voltage of the regulator. If an overshoot is large, the load circuit is adversely affected. Therefore it is important to determine the capacitor value so as to minimize undershoot and overshoot.

1. Line: Transient characteristics due to input voltage fluctuation

Input voltage fluctuation differs depending on the types of the signal applied: type 1 which is a rectangular wave between ($V_{OUT}+1$) V and 10 V, and type 2 which is a rectangular wave from 0 V to 10 V. (Refer to **Figure 25 to 26**) The ringing waveforms and parameter dependency of each type are described below. The measuring circuit is shown in **Figure 27** for reference.

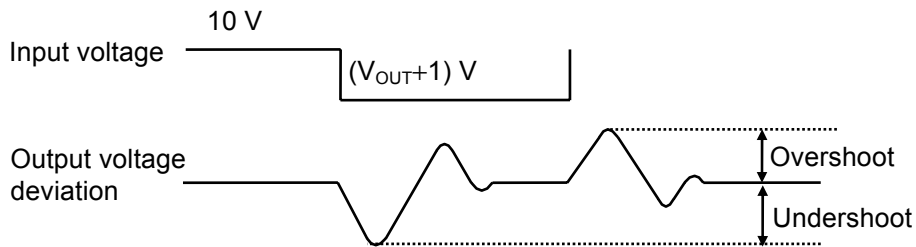
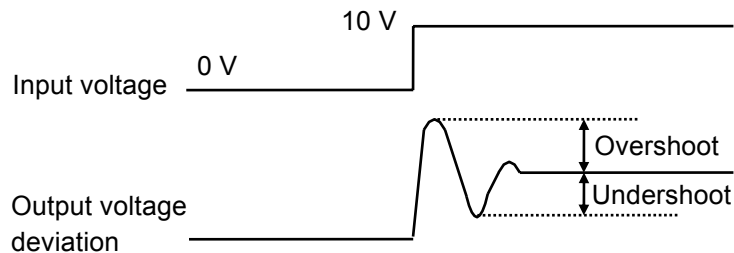
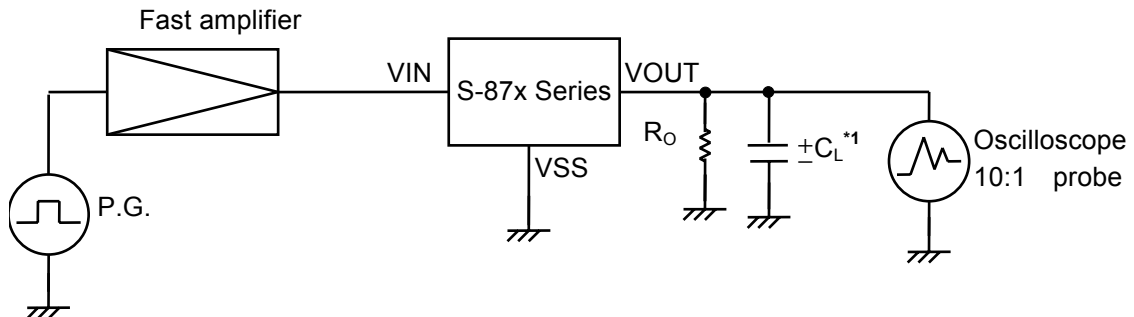

Figure 25 Rectangular wave between ($V_{OUT}+1$) V and 10 V (Type 1)



Remark Rise/fall time (time between 10 % and 90 %) is 1 μ s.

Figure 26 Rectangular wave from 0 V to 10 V (Type 2)



*1. AL electrolytic capacitor

Figure 27 Measuring circuit

Type 1 (Rectangle wave between (V_{OUT}+1) V and 10 V)

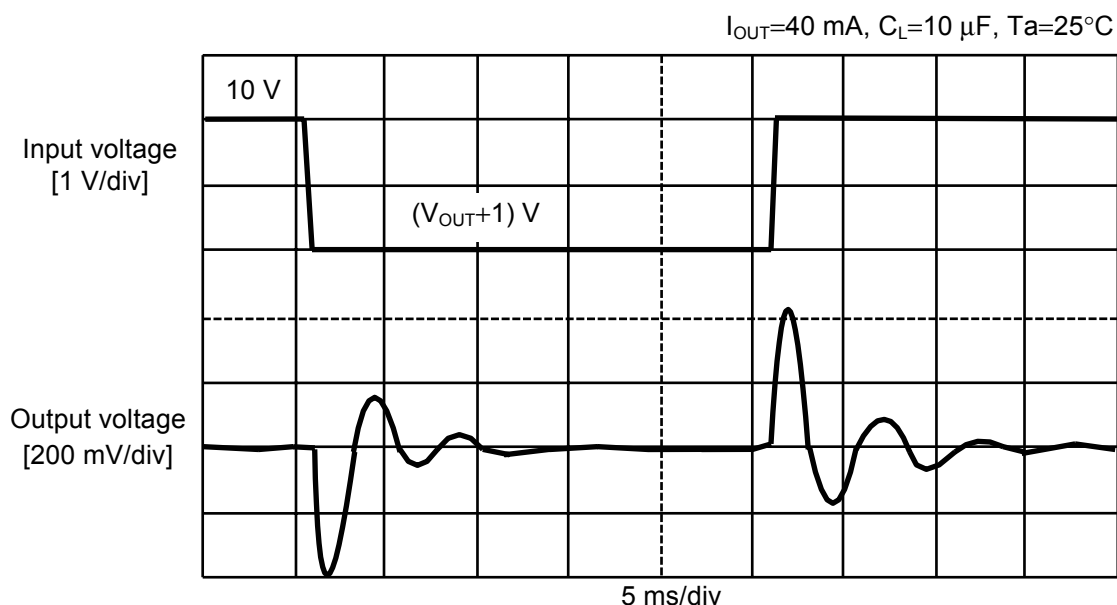

Overshoot amount: 350 mV
 Undershoot amount: 325 mV

Figure 28 Ringing waveform (Type 1)

Table 20 Parameter dependency (Type 1)

Series	Parameter	Conditions	Method to decrease overshoot	Method to decrease undershoot
S-8750xxx	Load current (I _{OUT})	10 to 60 mA, C _L =10 μF	Decrease	Decrease
	Load capacitance (C _L)	1 to 47 μF, I _{OUT} =40 mA	Increase	Increase
	Input fluctuation (ΔV _{IN} ^{*1})	2 to 4 V	Decrease	Decrease
		4 to 18 V	Increase	Decrease
Temperature (Ta)	-40 °C to +85 °C	Low temperature	Low temperature	
S-8730xxx	Load current (I _{OUT})	10 to 60 mA, C _L =10 μF	Increase	Decrease
	Load capacitance (C _L)	1 to 47 μF, I _{OUT} =40 mA	Increase	Increase
	Input fluctuation (ΔV _{IN} ^{*1})	4 to 20 V	Increase	Decrease
	Temperature (Ta)	-40 °C to +85 °C	Low temperature	Low temperature

*1. High voltage value – low voltage value

For reference, the following pages describe the ringing in V_{OUT} measured using the output load current (I_{OUT}), output load capacitance (C_L), input fluctuation width (ΔV_{IN}), and temperature (Ta) as parameters.

Reference Data: Type 1

S-8750xxx Series

1. I_{OUT} Dependency

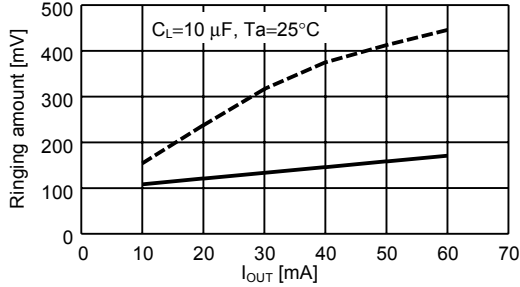

2. C_L Dependency

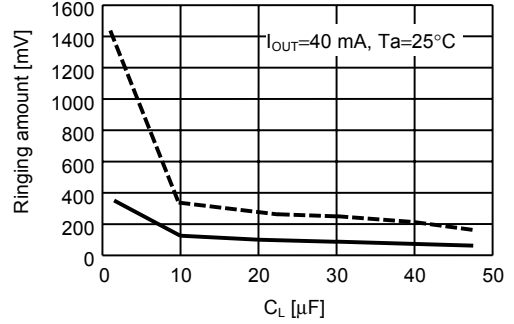

3. ΔV_{IN} Dependency

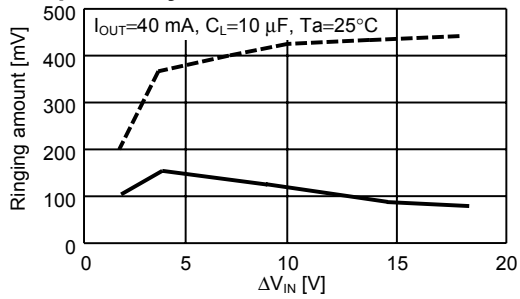

4. Temperature Dependency

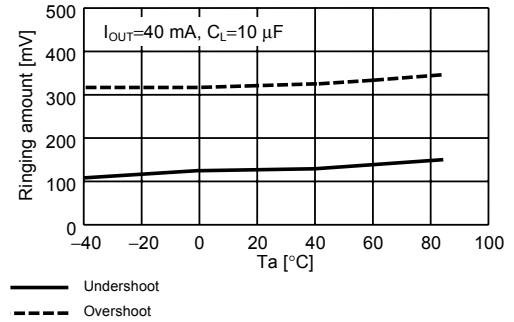

Remark The lower voltage is fixed at 6 V.

S-8730xxx Series

1. I_{OUT} Dependency

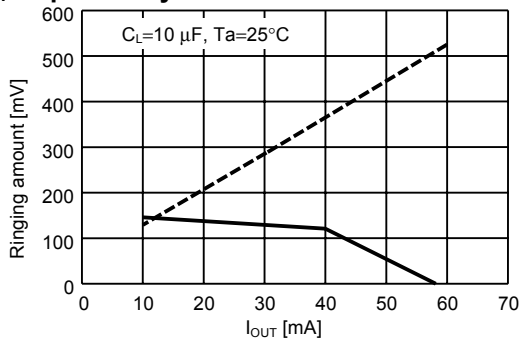

2. C_L Dependency

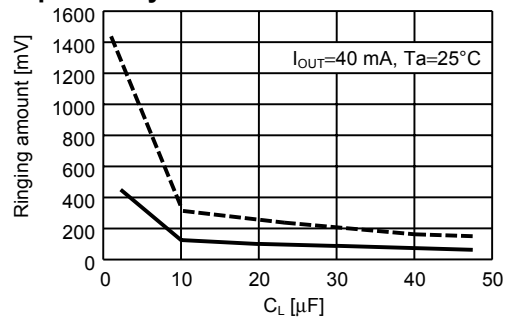

3. ΔV_{IN} Dependency

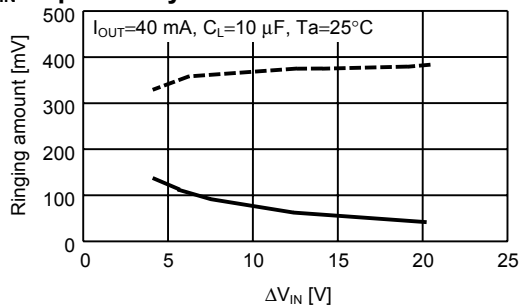

4. Temperature Dependency

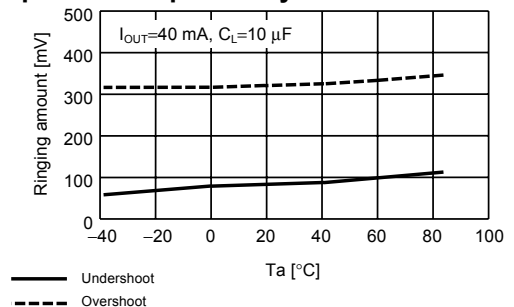

Remark The lower voltage is fixed at 4 V.

Type 2 (Rectangle wave form 0 V to 10 V)

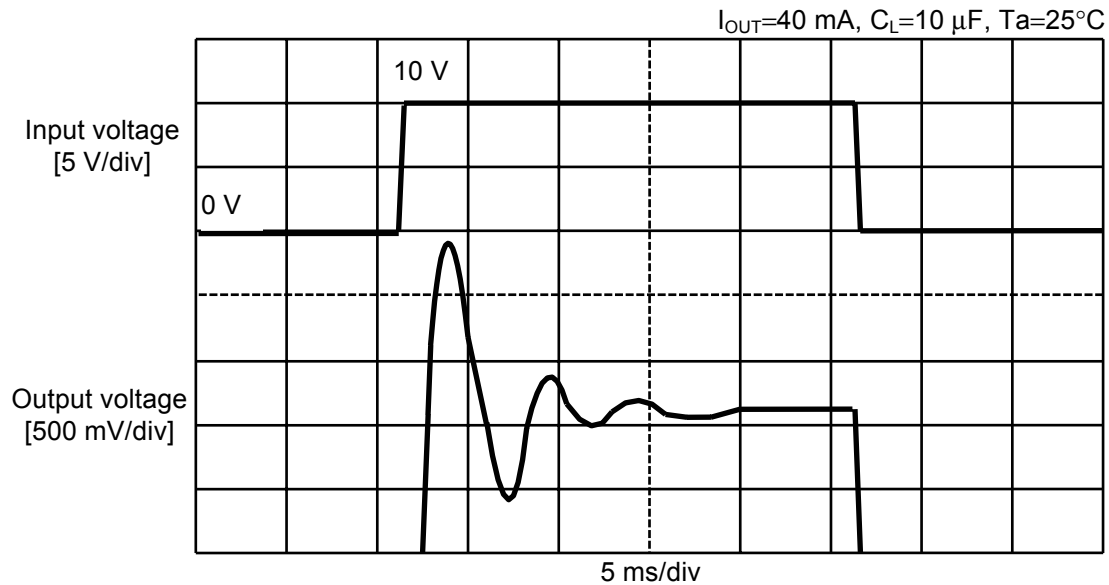

Overshoot amount: 1300 mV
 Undershoot amount: 610 mV

Figure 29 Ringing waveform (Type 2)

Table 21 Parameter dependency (Type 2)

Series	Parameter	Conditions	Method to decrease overshoot	Method to decrease undershoot
S-8750xxx	Load current (I_{OUT})	10 to 60 mA, $C_L=10 \mu F$	Increase	Increase
	Load capacitance (C_L)	1 to 47 μF , $I_{OUT}=40 \text{ mA}$	Decrease	Decrease
	Input fluctuation (ΔV_{IN}^{*1})	8 to 24 V	Increase	Increase
	Temperature (T_a)	-40 °C to +85 °C	Low temperature	Low temperature
S-8730xxx	Load current (I_{OUT})	10 to 60 mA, $C_L=10 \mu F$	Increase	Increase
	Load capacitance (C_L)	1 to 47 μF , $I_{OUT}=40 \text{ mA}$	Decrease	Decrease
	Input fluctuation (ΔV_{IN}^{*1})	8 to 24 V	Increase	Increase
	Temperature (T_a)	-40 °C to +85 °C	Low temperature	Low temperature

*1. High voltage value – 0 V

For reference, the following pages describe the ringing in V_{OUT} measured using the output load current (I_{OUT}), output load capacitance (C_L), input fluctuation width (ΔV_{IN}), and temperature (T_a) as parameters.

Reference Data: Type 2

S-8750xxx Series

1. I_{OUT} Dependency

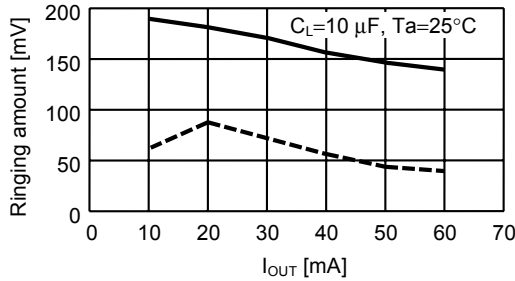

2. C_L Dependency

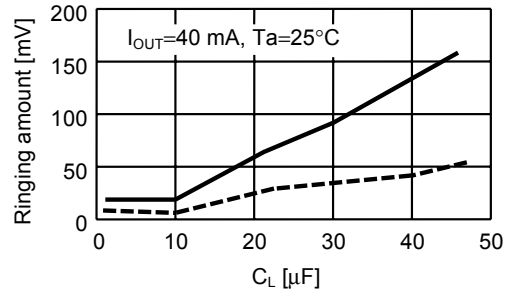

3. ΔV_{IN} Dependency

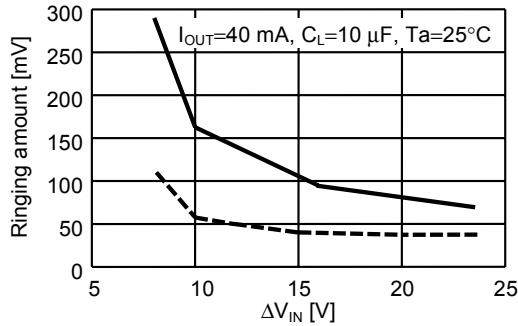

4. Temperature Dependency

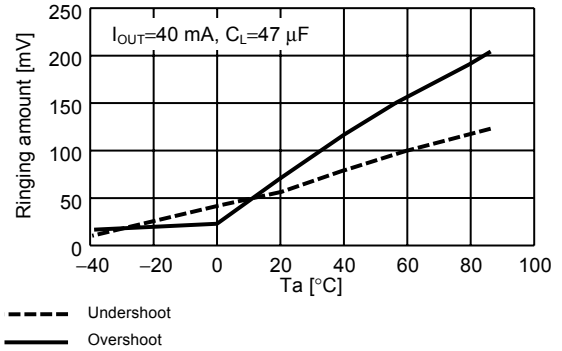

Remark The lower voltage is fixed at 0 V.

S-8730xxxSeries

1. I_{OUT} Dependency

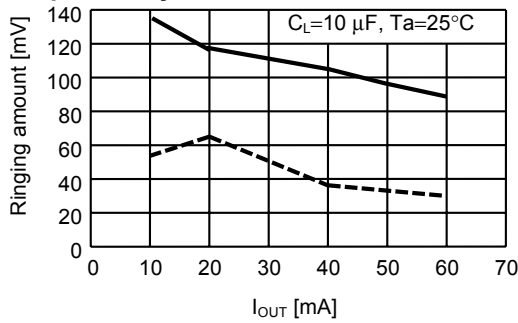

2. C_L Dependency

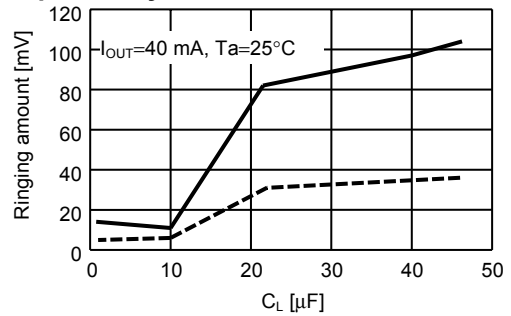

3. ΔV_{IN} Dependency

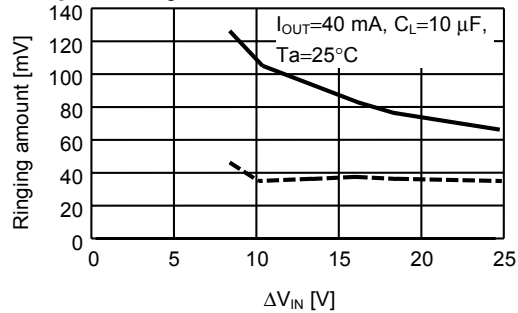

4. Temperature Dependency

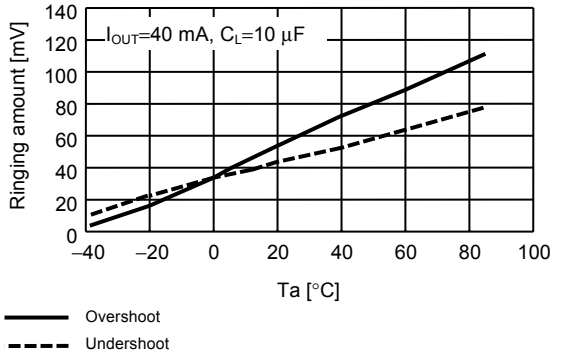

Remark The lower voltage is fixed at 0 V.

2. Load transient response characteristics due to load current fluctuation

An overshoot and an undershoot are caused in the output voltage if the load current is changed from 50 μA to 40 mA while the input voltage is kept constant. **Figure 30** shows the output voltage fluctuation due to a change in the load current. The measuring circuit is shown in **Figure 31** for reference. The latter half of this section describes ringing waveform and parameter dependency.

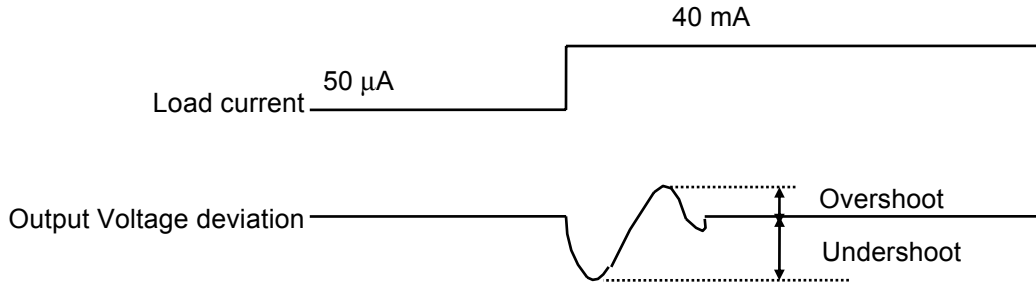
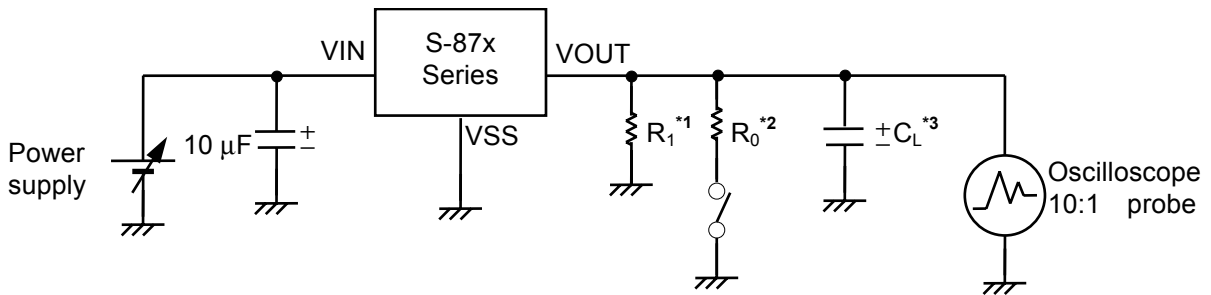

Figure 30 Output voltage fluctuation due to a change in the load current



*1. $R_1 = \frac{V_{OUT}[V]}{50 \mu A} [\Omega]$

*2. $R_0 = \frac{V_{OUT}[V]}{40 mA} [\Omega]$

*3. AL electrolytic capacitor

Figure 31 Measuring circuit

Table 22 Parameter dependency due to load current fluctuation

Series	Parameter	Conditions	Method to decrease overshoot	Method to decrease undershoot
S-8750xxx, S-8730xxx	Load current (I_{OUT})	10 to 60 mA, $C_L=10 \mu F$	Decrease	Decrease
	Load capacitance (C_L)	1 to 47 μF, $I_{OUT}=40 mA$	Increase	Increase
	Power supply voltage (V_{IN})	($V_{OUT}+1$) to 24 V	Increase	Increase
	Temperature (T_a)	-40 °C to +85 °C	Low temperature	Low temperature

■ Reference Data

S-8750xxxSeries

1. I_{OUT} Dependency

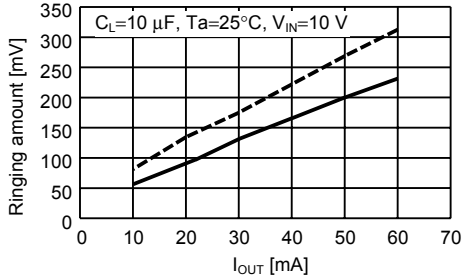

Remark The lower current is fixed at 50 μA.

2. C_L Dependency

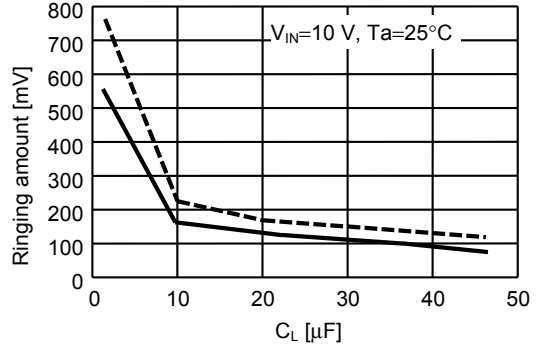

3. ΔV_{IN} Dependency

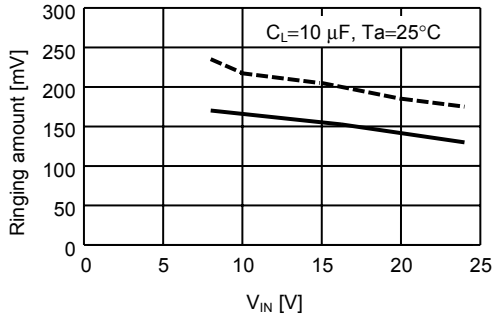

4. Temperature Dependency

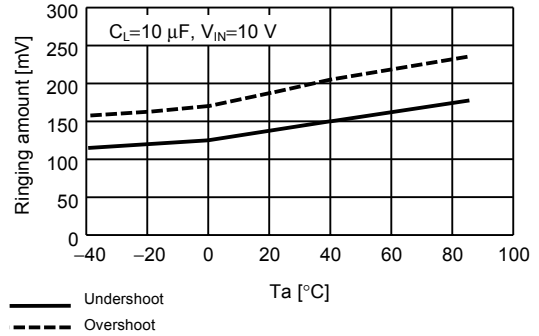

S-8730xxxSeries

1. I_{OUT} Dependency

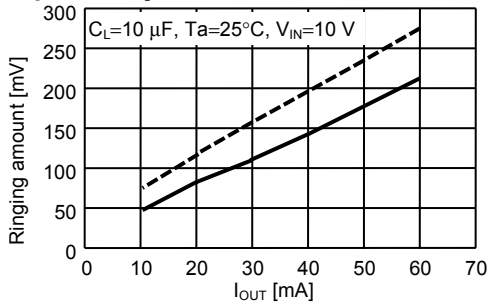

Remark The lower current is fixed at 50 μA.

2. C_L Dependency

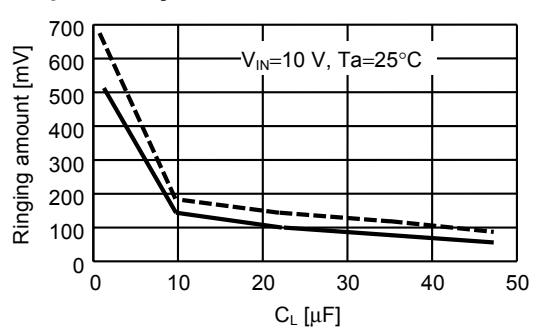

3. ΔV_{IN} Dependency

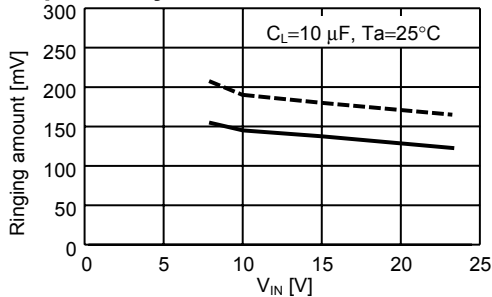

4. Temperature Dependency

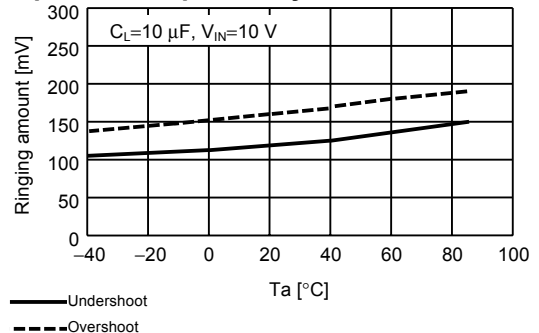

■ Standard Circuits

1. A/B/F type

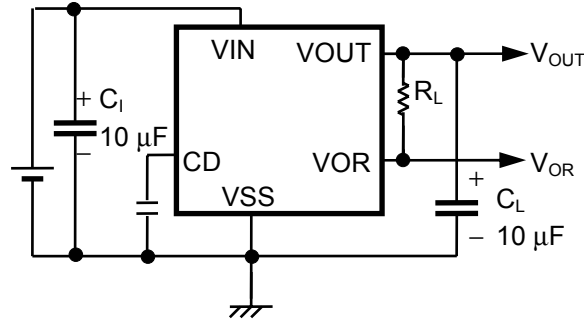

Figure 32

2. C/G type

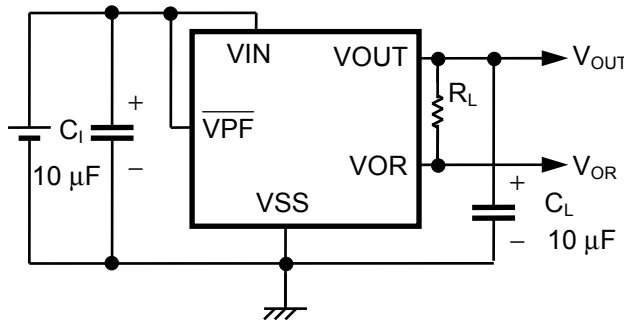

Figure 33

3. E type

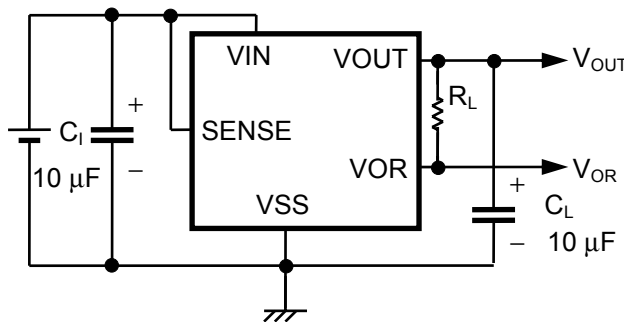

Figure 34

Caution The above connection diagram and constants do not guarantee correct operation. Perform sufficient evaluation using the actual application to set the constants.

■ **Application Circuits**

1. Microcomputer power supply and reset circuit

To construct a microcomputer power supply and a reset circuit using conventional ICs, a voltage regulator IC, a voltage detector IC, a delay time generation circuit and others are required. The A/B type allows you to make these circuits without these ICs, and the delay time is variable.

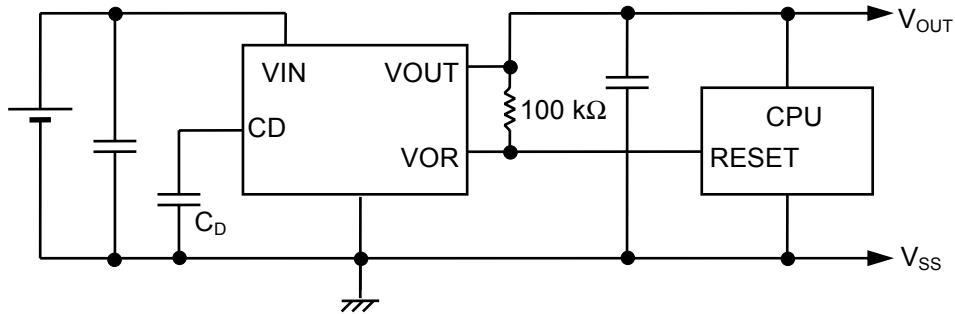

Figure 35

Caution The above connection diagram and constants do not guarantee correct operation. Perform sufficient evaluation using the actual application to set the constants.

2. Output current boost circuit

A PNP transistor is used to increase the output current.

1. A/ B type

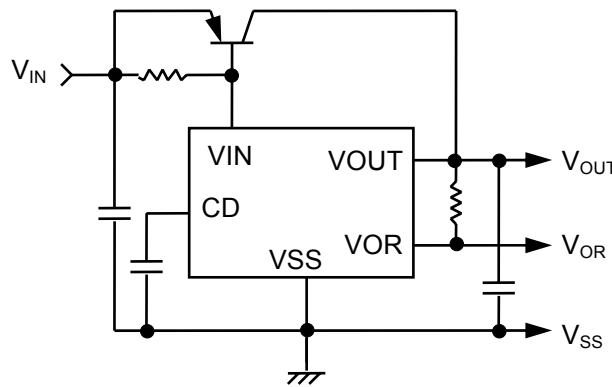

Figure 36

2. C/ G type

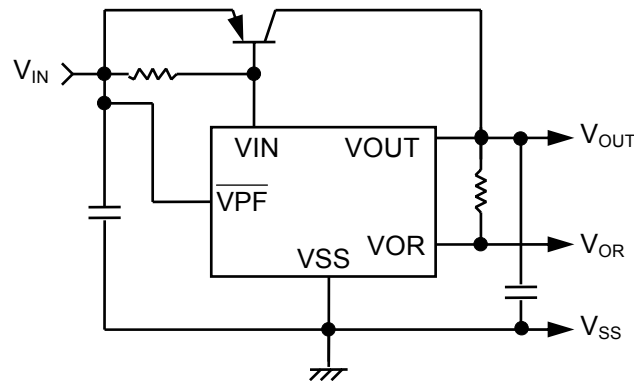

Figure 37

Caution The above connection diagram and constants do not guarantee correct operation. Perform sufficient evaluation using the actual application to set the constants.

3. Power supply for lithium-ion battery pack

When the lithium-ion battery goes down to the overdischarge voltage, the built-in voltage detector powers OFF the voltage regulator, and at the same time it transmits the RESET signal to the microcomputer. R_1 , C_1 , R_2 and C_2 are attached to eliminate the voltage exceeding the absolute maximum ratings of charger. C_3 is attached to give a delay and to release the RESET signal after power supply voltage for microcomputer (V_{OUT}) rises high enough.

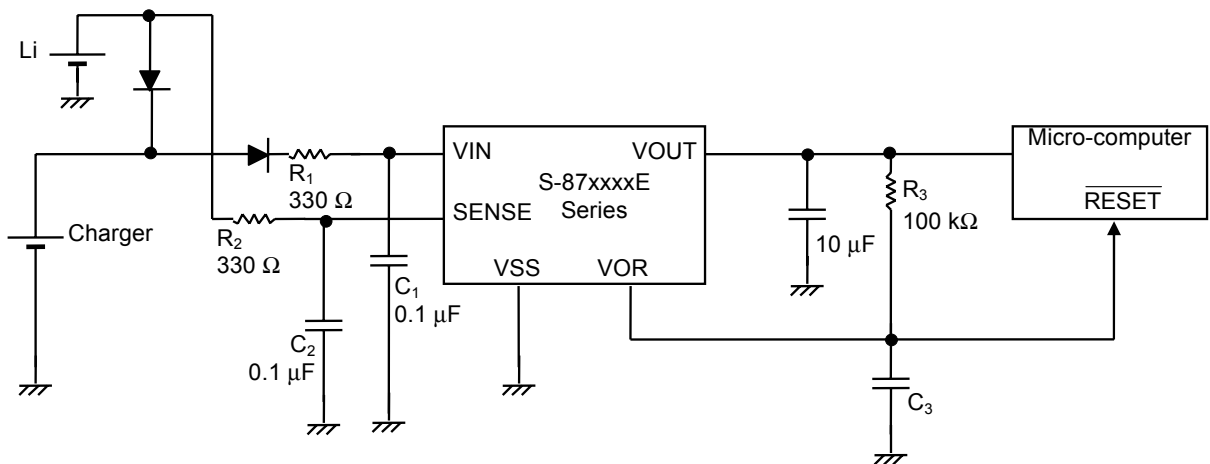

Figure 38

Caution The above connection diagram and constants do not guarantee correct operation. Perform sufficient evaluation using the actual application to set the constants.

Power Dissipation of the Package

Use a voltage regulator under the specified power dissipation of the package.

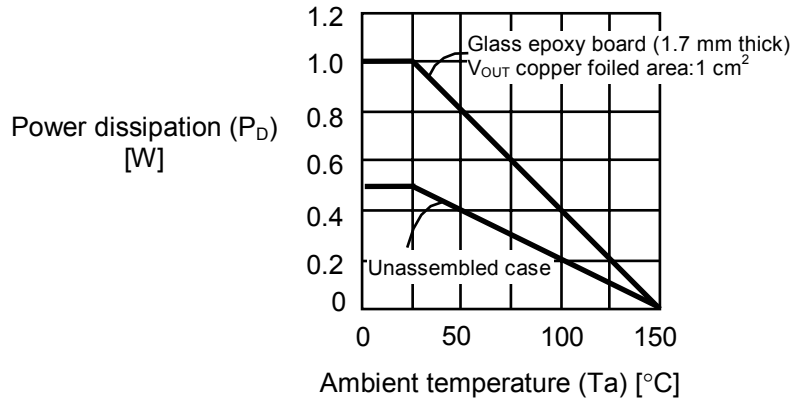
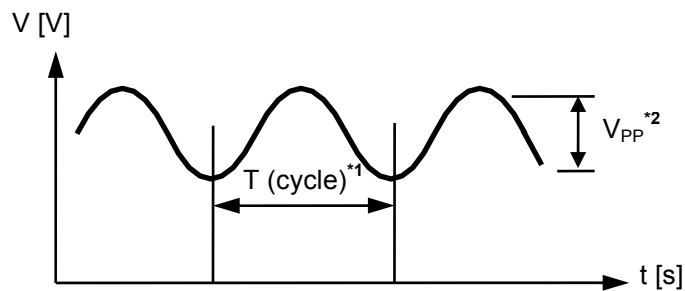

Figure 39

Precautions

- DO NOT apply a ripple voltage of the following both conditions to VIN pin.



*1. $f \geq 1000 \text{ Hz}$ ($f = \frac{1}{T}$) ("f" shows the frequency)

*2. $V_{pp} \geq 0.5 \text{ V}$

Figure 40

- When connecting another power supply to the voltage regulator output pin, insert a diode to protect the IC.

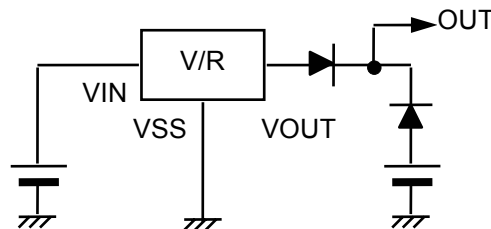

Figure 41

- Do not apply an electrostatic discharge to this IC that exceeds the performance ratings of the built-in electrostatic protection circuit.

■ Characteristics (Typical Data)

1. Voltage regulator

(1) Output voltage (V_{OUT}) - Temperature (T_a) characteristics

S-8750xxx Series

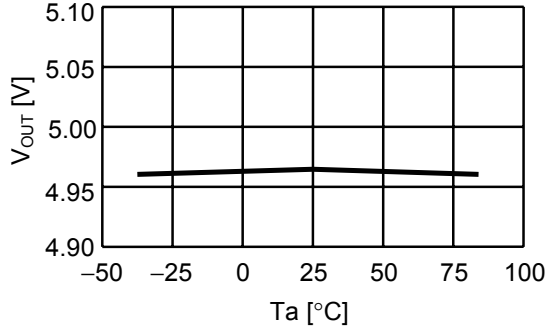

S-8730xxx Series

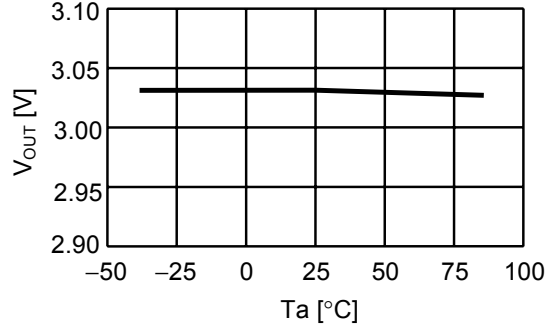

(2) Line regulation (ΔV_{OUT1}) - Temperature (T_a) characteristics

S-8750xxx Series

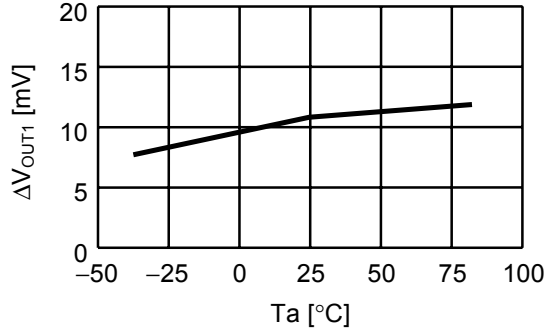

S-8730xxx Series

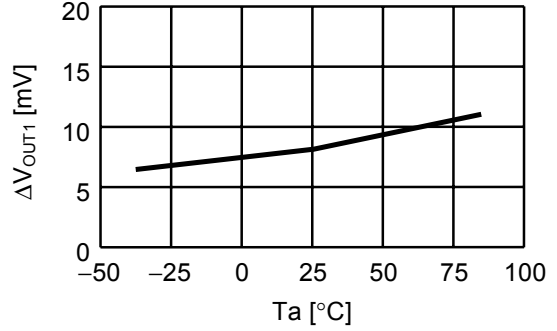

(3) Input voltage (V_{IN}) - Output voltage (V_{OUT}) characteristics

S-8750xxx Series

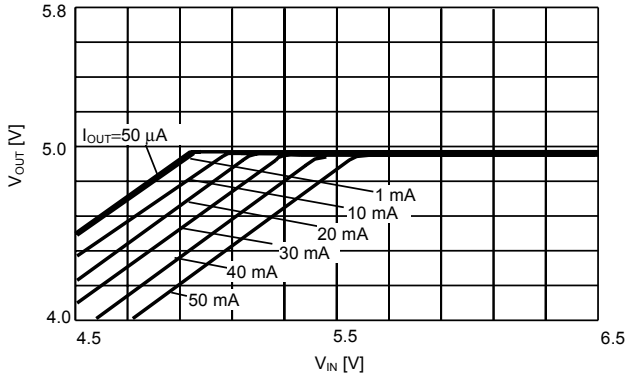

S-8730xxx Series

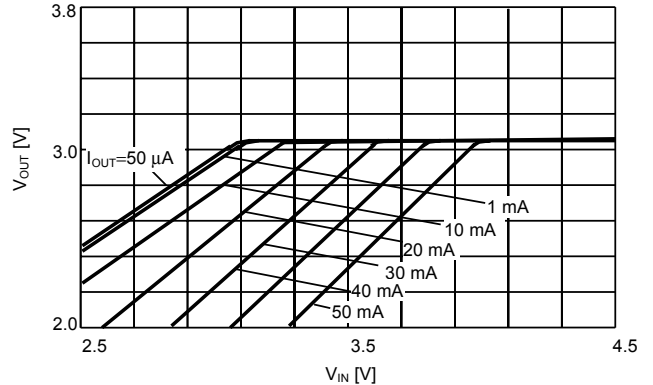

(4) Load regulation(ΔV_{OUT2}) - Temperature (T_a) characteristics

S-8750xxx Series

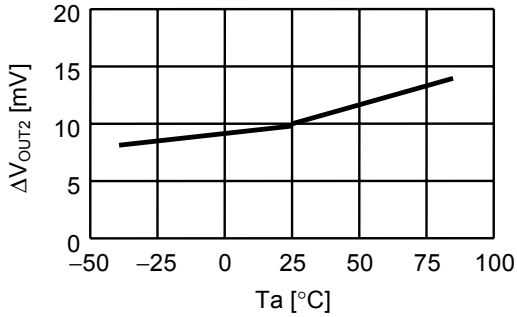

S-8730xxx Series

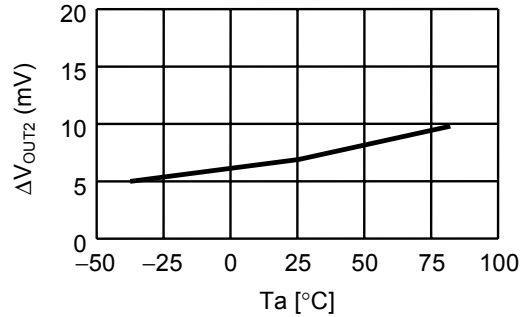

(5) I/O voltage difference (V_{dif}) - Temperature (T_a) characteristics

S-8750xxx Series

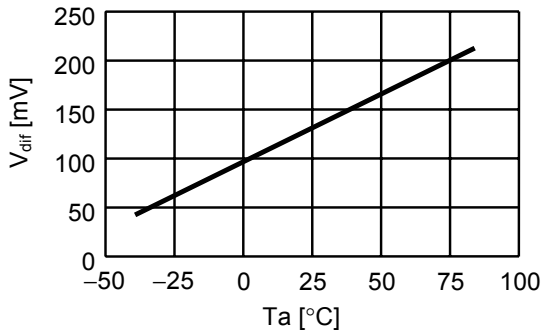

S-8730xxx Series

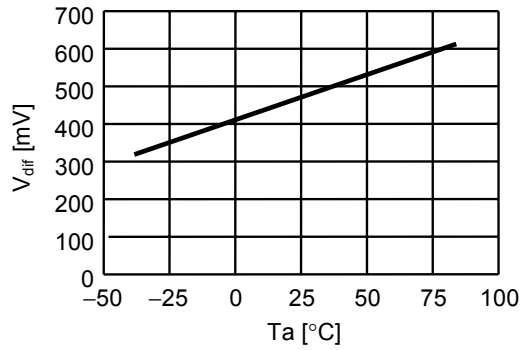

(6) Short-circuit protection circuit characteristics

S-8750xxx Series ($T_a=25^\circ\text{C}$)

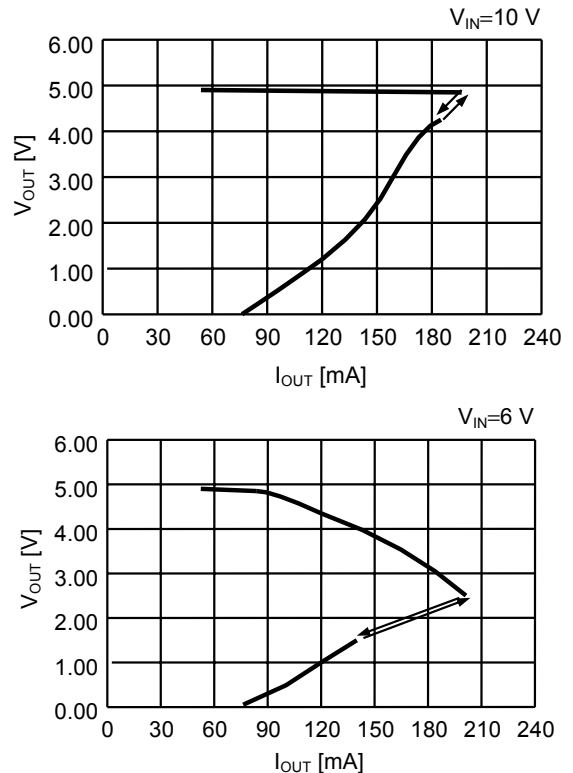
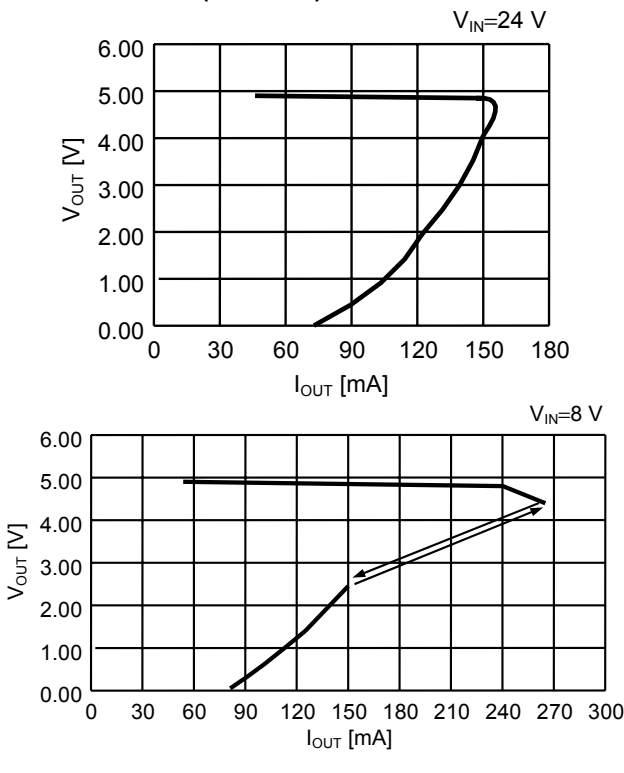

HIGH WITHSTAND-VOLTAGE VOLTAGE REGULATOR WITH RESET FUNCTION

Rev.7.1_00

S-87x Series

S-8730xxx Series (Ta=25°C)

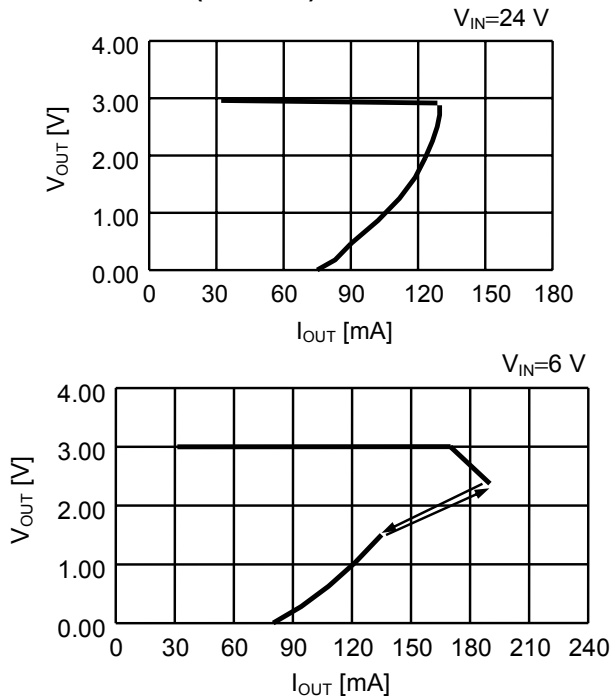

S-8730xxx Series

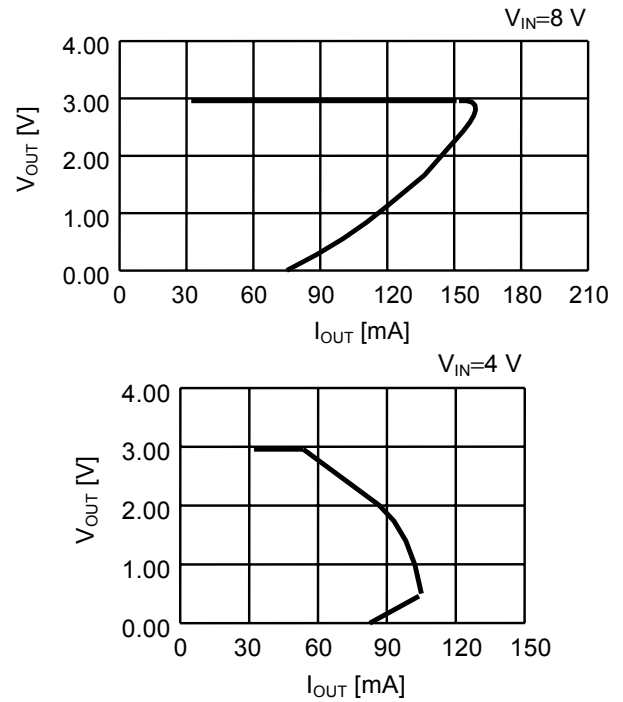

(7) Ripple rejection characteristics

S-8750xxx Series

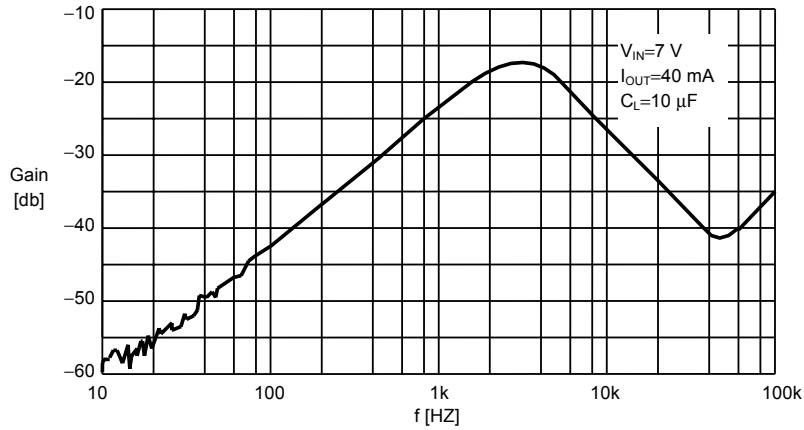

S-8730xxx Series

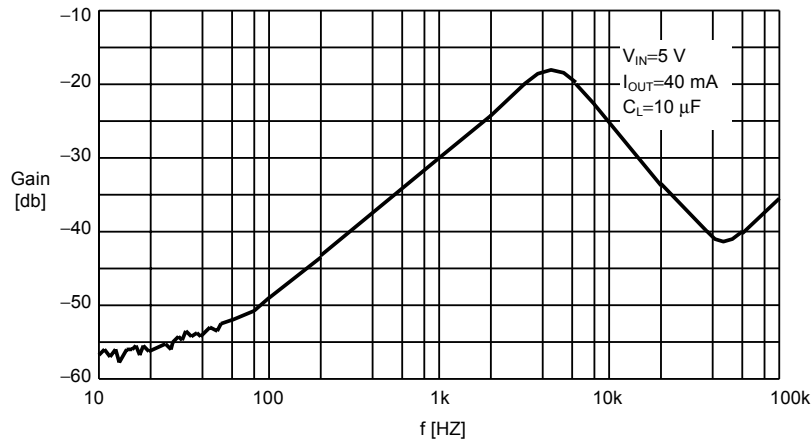

2. Voltage detector

(1) Detection voltage (V_{DET}) - Temperature (T_a) characteristics

S-875045

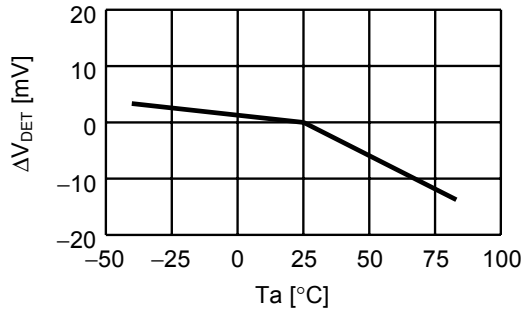

S-875043

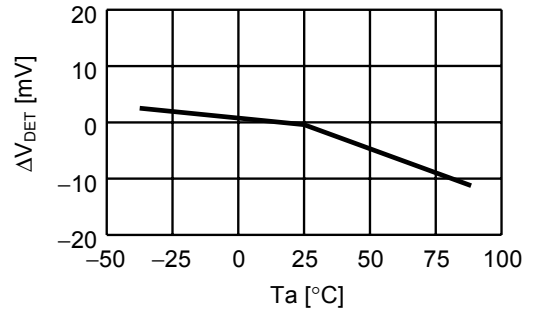

S-873023

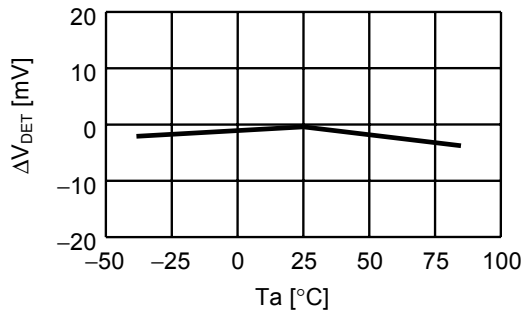

(2) Hysteresis width (V_{HYS}) - Temperature (T_a) characteristics

S-875045

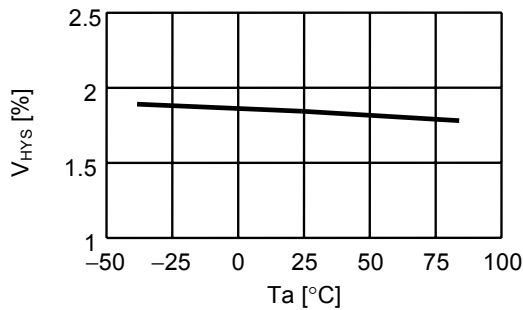

S-875043

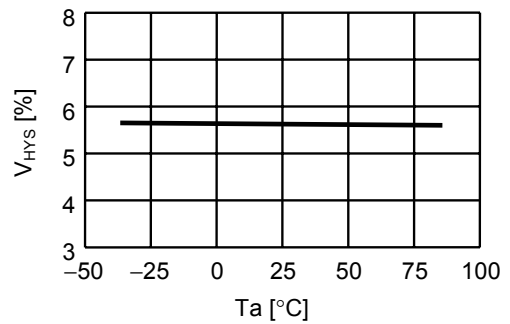

S-873023

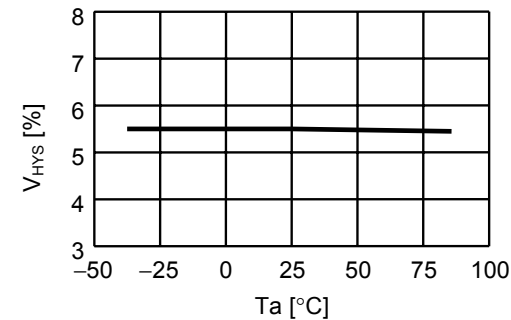

(3) Nch transistor output current (I_{DOUT}) characteristics

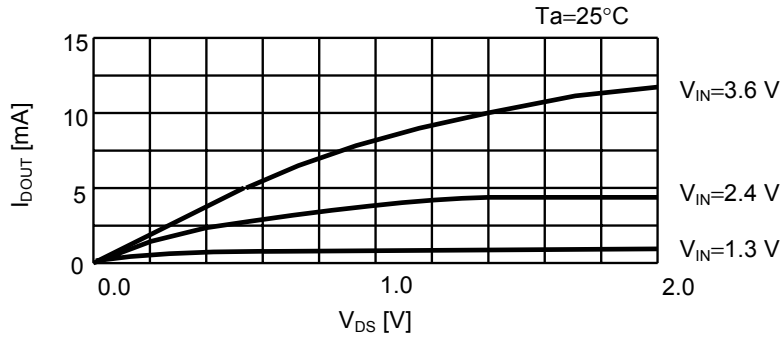

(4) Delay time (t_{pd}) characteristics

Delay time (t_{pd}) - Temperature (T_a)

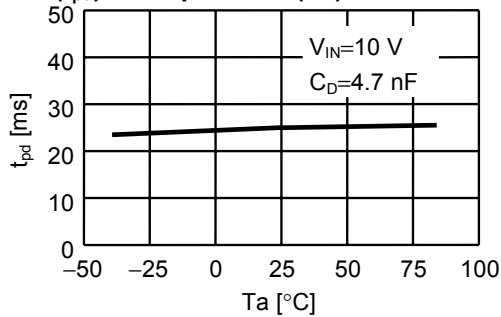

3. Total

(1) Current consumption (I_{SS}) characteristics

(a) Input voltage (V_{IN}) characteristics

S-8750xxC Series

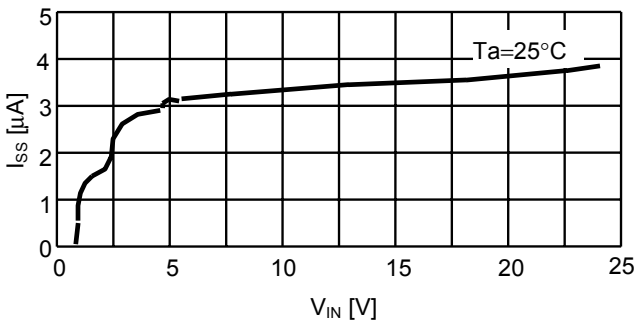

S-8730xxC Series

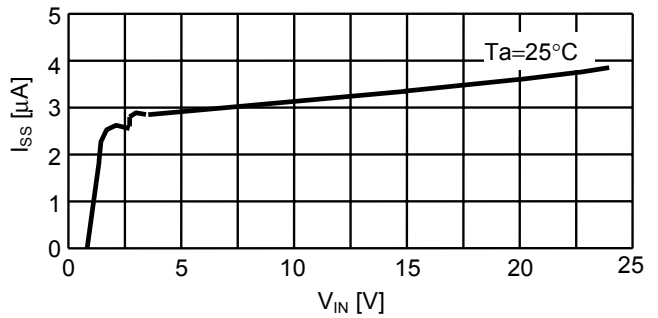

(b) Current consumption (I_{SS}) - Temperature (T_a) characteristics

S-8750xxC Series

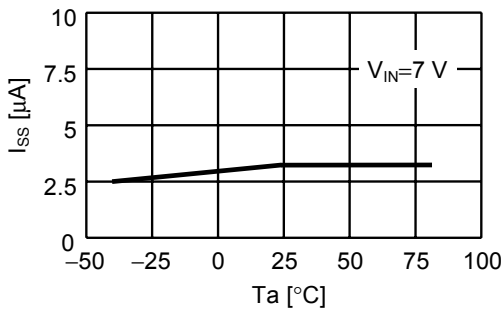

S-8730xxC Series

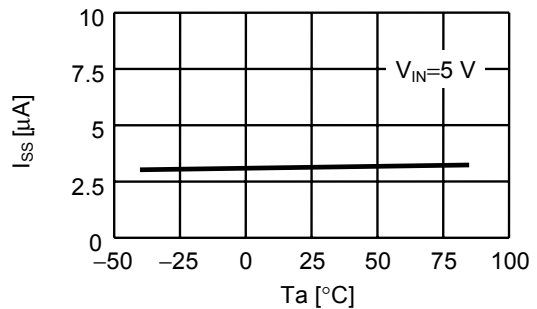

(2) Input voltage of shutdown circuit characteristics

(a) High level input voltage (V_{IH}) - Temperature (T_a) characteristics

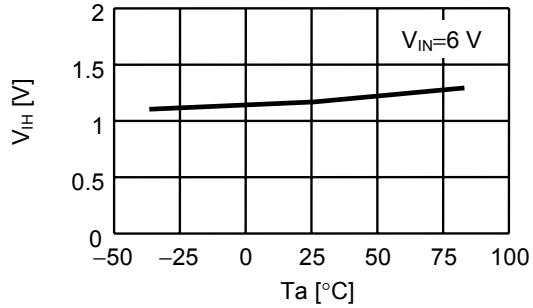

(b) Low level input voltage (V_{IL}) - Temperature (T_a) characteristics

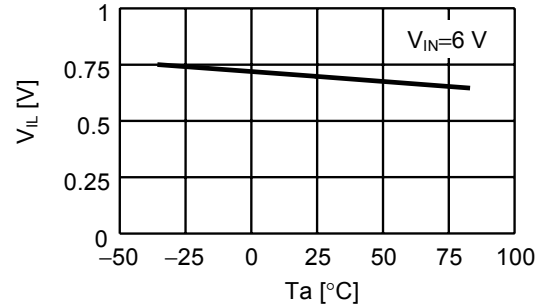

(c) V_{IH} , V_{IL} - Power supply voltage dependency characteristics

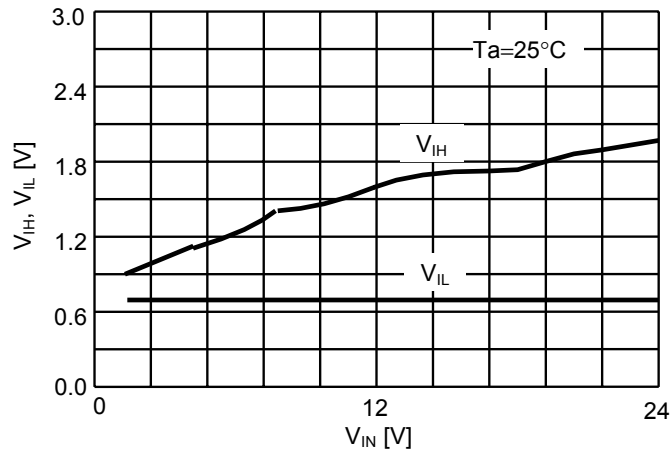

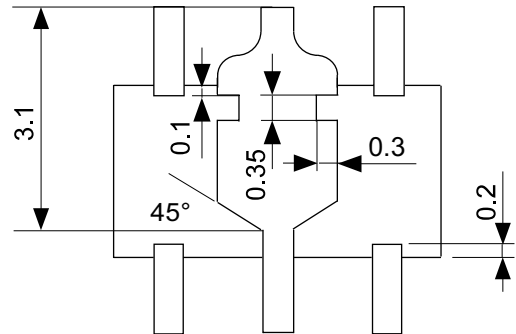
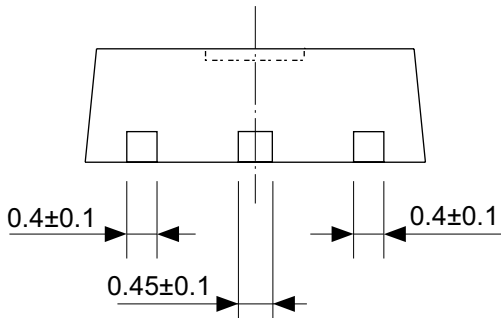
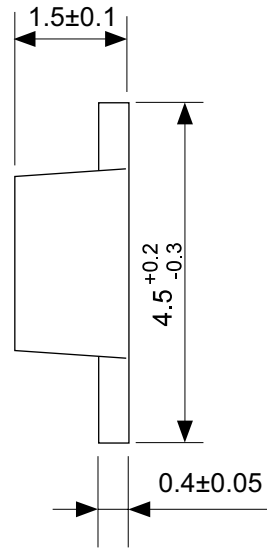
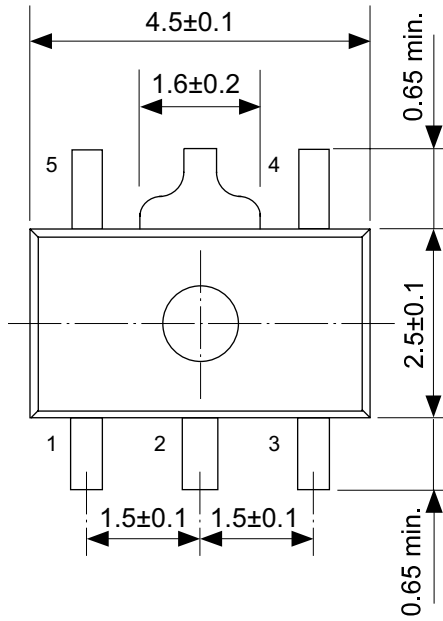

No. UP005-A-P-SD-1.1

TITLE	SOT895-A-PKG Dimensions
No.	UP005-A-P-SD-1.1
SCALE	
UNIT	mm
Seiko Instruments Inc.	

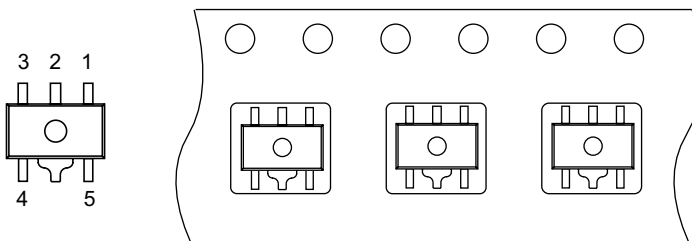
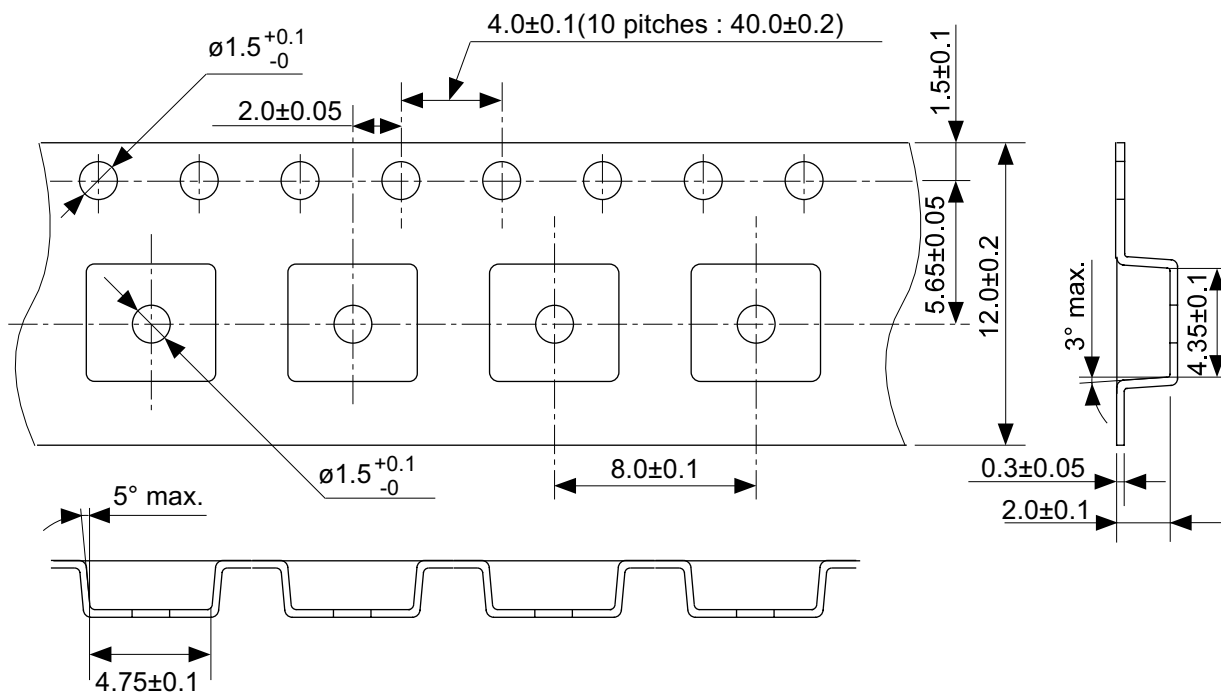

No. UP005-A-C-SD-1.1

TITLE	SOT895-A-Carrier Tape
No.	UP005-A-C-SD-1.1
SCALE	
UNIT	mm
Seiko Instruments Inc.	

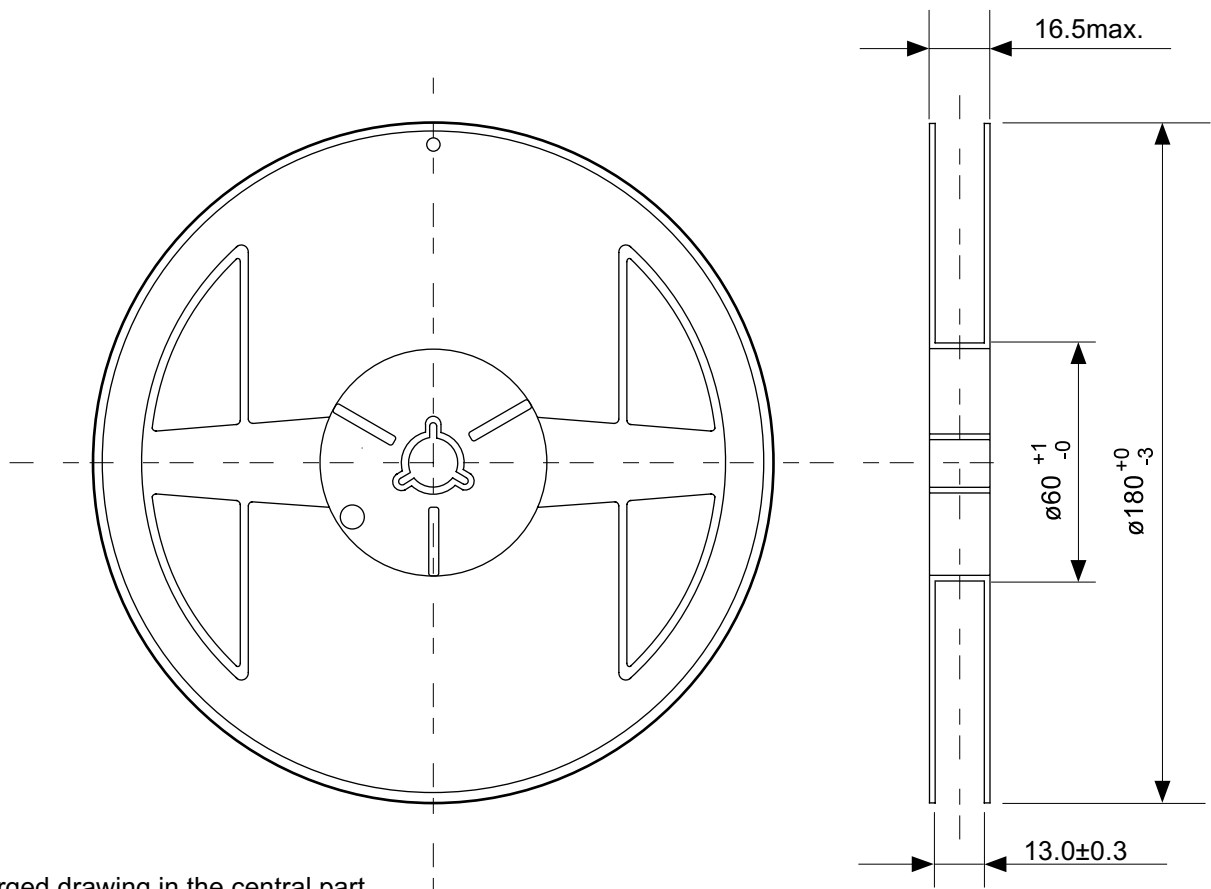

Enlarged drawing in the central part

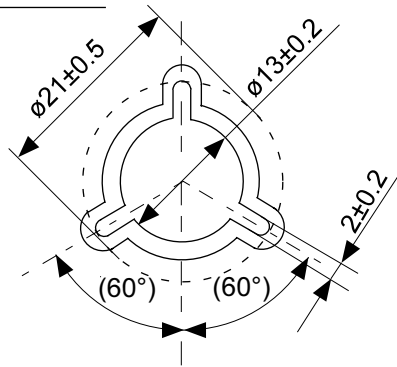

No. UP005-A-R-SD-1.1

TITLE	SOT895-A-Reel		
No.	UP005-A-R-SD-1.1		
SCALE		QTY.	1,000
UNIT	mm		
Seiko Instruments Inc.			

- The information described herein is subject to change without notice.
- Seiko Instruments Inc. is not responsible for any problems caused by circuits or diagrams described herein whose related industrial properties, patents, or other rights belong to third parties. The application circuit examples explain typical applications of the products, and do not guarantee the success of any specific mass-production design.
- When the products described herein are regulated products subject to the Wassenaar Arrangement or other agreements, they may not be exported without authorization from the appropriate governmental authority.
- Use of the information described herein for other purposes and/or reproduction or copying without the express permission of Seiko Instruments Inc. is strictly prohibited.
- The products described herein cannot be used as part of any device or equipment affecting the human body, such as exercise equipment, medical equipment, security systems, gas equipment, or any apparatus installed in airplanes and other vehicles, without prior written permission of Seiko Instruments Inc.
- Although Seiko Instruments Inc. exerts the greatest possible effort to ensure high quality and reliability, the failure or malfunction of semiconductor products may occur. The user of these products should therefore give thorough consideration to safety design, including redundancy, fire-prevention measures, and malfunction prevention, to prevent any accidents, fires, or community damage that may ensue.