

DATE OF ISSUE : 2005. 07. 21

SPECIFICATION

MODEL : SLSNNWH822TS

WHITE FLASH LED

CUSTOMER : _____

SAMSUNG ELECTRO-MECHANICS CO, .LTD.

314. MAETAN3-DONG, YEONGTONG-KU,
SUWON-SI, KYUNGKI-DO, KOREA, 442-743

Contents

1. Product outline-----	3
2. Absolute Maximum Rating-----	3
3. Characteristics -----	3
4. Chromaticity Diagram -----	4
5. Typical Characteristic Graph -----	5
6. Outline Drawing and Dimension -----	6
7. Package Structure -----	6
8. Reliability Test Items and Conditions --	7
9. Solder Conditions -----	8
10. Taping Dimension -----	9
11. Reel Packing Structure -----	10
12. Label Structure -----	11
13. Precaution for Use -----	12
14. Hazard Substance Analysis-----	13~14
15 Revision History -----	15

■ Product Outline

1) Feature

1. Mini-Mold type (3.2 * 2.8 * t 1.9mm),
2. Beam Angle ($\Delta\theta$: 120 °)
3. GaN/Al₂O₃ Chip & Long Time Reliability

2) Applications

- Mobile Camera Phone, Flashlight for Camera.....

■ Absolute Maximum Rating

- Operation Forward Current Per Chip..... 30 mA
- Peak Pulsed Forward Current Per Chip..... 100 mA
(Duty 1/10 Pulse Width 10msec)
- Reverse Voltage 5V
- Operating Temperature Range (T_{opr}) -35°C ~ 85°C
- Storage Temperature Range (T_{stg}) -40°C ~ 100°C

■ Characteristics

(Ta : 25°C)

	Rank	Symbol	Min.	Typ.	Max.	Unit	Conditions
Forward Voltage	S	V _F	2.9	3.4	3.8	V	I _F = 60mA 30mA/die
Reverse Current	-	I _r	-	-	100	μA	V _r = 5V

Chromaticity Coordinate

Rank	x				y				Condition
E	0.287	0.281	0.330	0.330	0.295	0.308	0.365	0.339	I _F = 60mA 30mA/die
F	0.287	0.296	0.330	0.330	0.295	0.276	0.318	0.339	

Luminous Intensity

Rank	Symbol	Min.	Typ.	Max.	Unit	Conditions
S	IV	2.0	3.0	4.0	cd	I _F = 60mA 30mA/die
-	IV	-	6.5	8.0	cd	I _F =150mA, 75mA/die (2sec-On/2sec-OFF)

- * Tolerance : V_F:±0.1, IV:±10%, x,y:±0.02
- * Luminous intensity measuring equipment : CAS140 B

■ Chromaticity Diagram

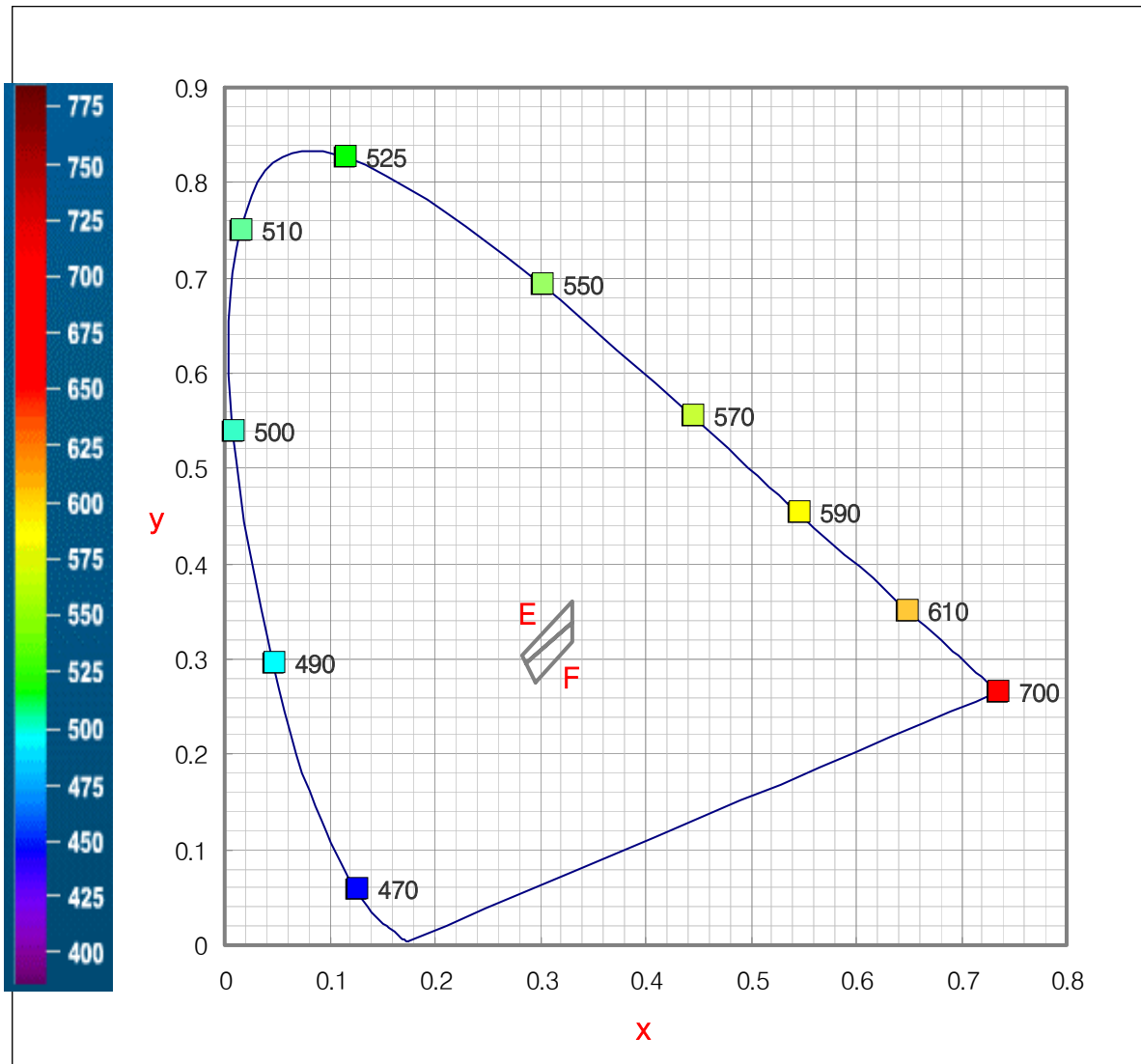

Typical Characteristics Graph

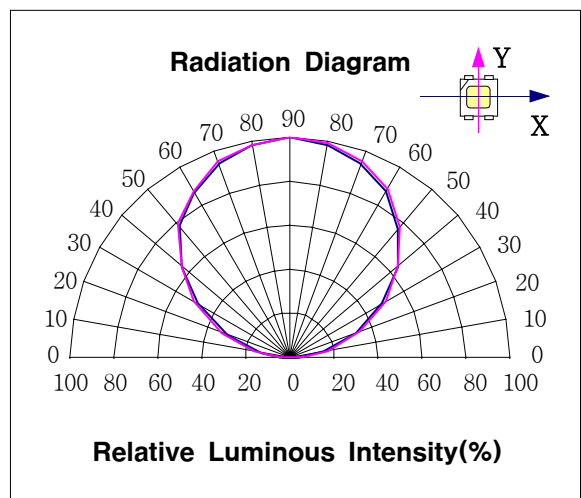
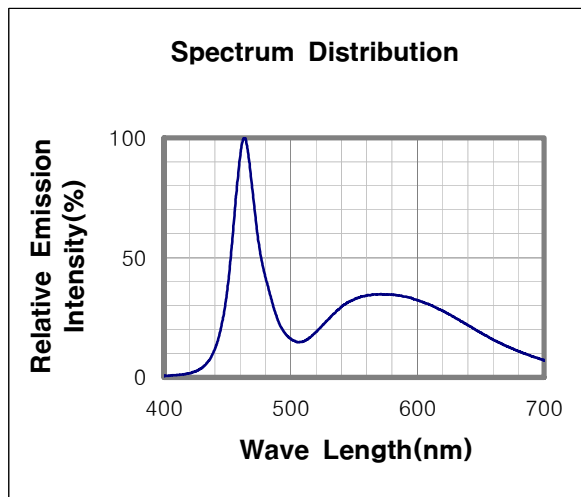
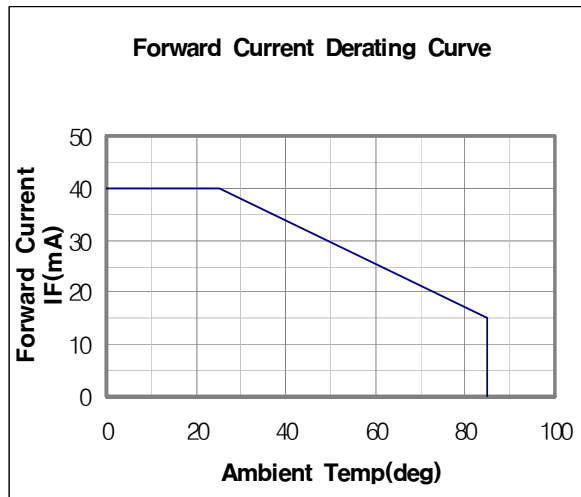
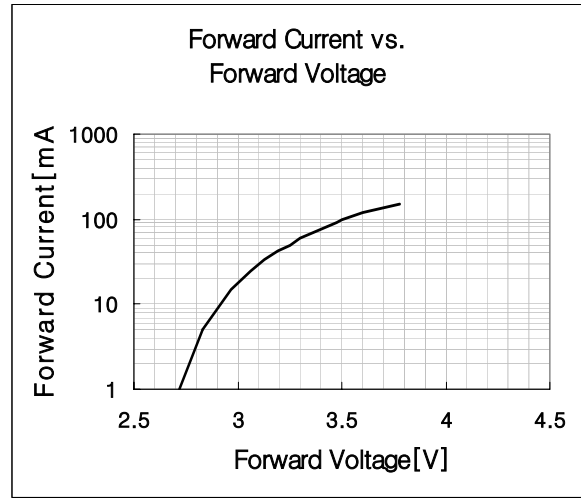
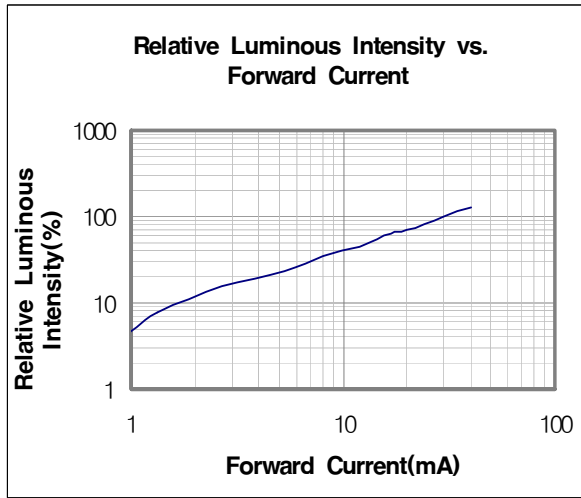

■ Outline Drawing and Dimension

unit:mm
Tolerance: ±0.1

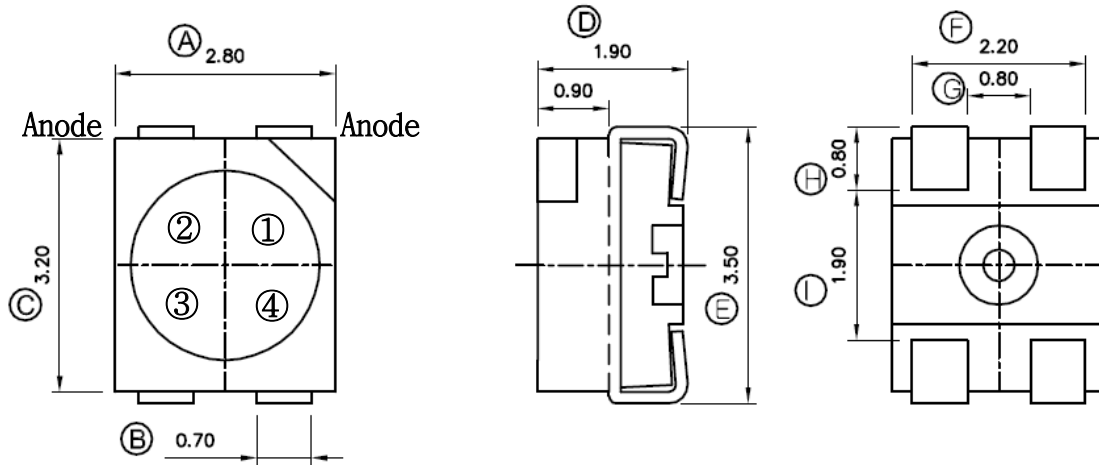

Circuit

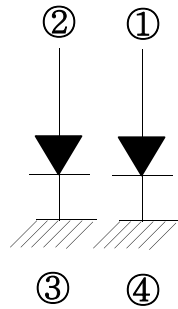

Land Layout

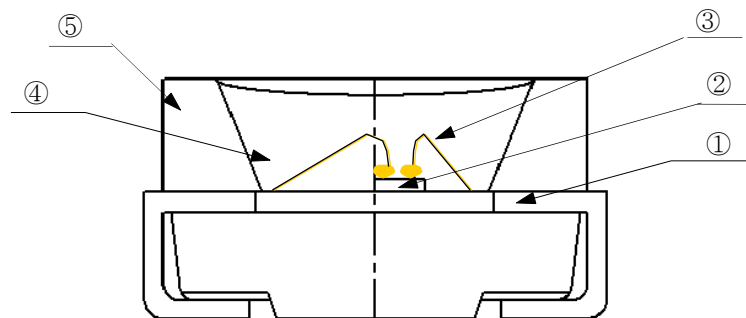
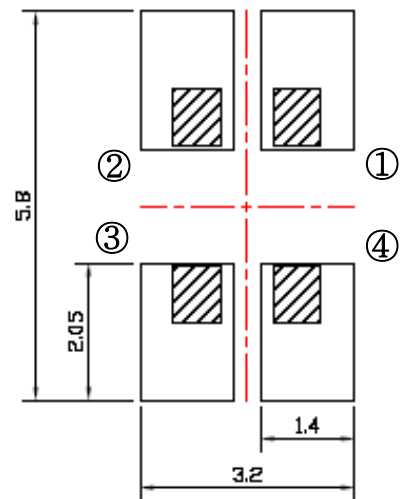

NUMBER	ITEM	MATERIAL
①	FRAME	Copper Frame(Silver Plated)
②	LED CHIP	GaN/Al ₂ O ₃
③	WIRE	Gold Wire
④	RESIN	Resin + Phosphor
⑤	PACKAGE	Heat-resistant Polymer

■ Reliability Test Items and Conditions

1) Test Items and Results

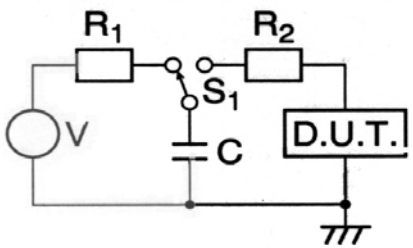
Test Item	Test Conditions	Test Hours/Cycles	Sample No
Room Temperature life test	25°C±3°C, DC60 mA	500 h	0/50
High Temperature humidity life test	60°C±3°C, 95%±2%RH, DC27.5 mA	500 h	0/50
High Temperature life test	85°C±3°C, DC12.5mA	500 h	0/50
Low Temperature life test	-30°C±3°C, DC60 mA	500 h	0/50
High Temperature Storage	Ta=100°C±3°C	500 h	0/50
Low Temperature Storage	Ta=-40°C±3°C	500 h	0/50
High Temperature humidity Storage	60°C±3°C, 95%±2%RH	500 h	0/50
Thermal Shock	-40°C ~ 100°C 0.5 h 0.5 h	100 cycles	0/50
Temperature humidity Cycle	25°C ~ 65°C ~ -10°C 24hrs/1cycle, 95%RH	10 cycles	0/22
Reflow (Pb-Free)	Peak 260±5°C for 10sec	3 times	0/22
ESD(HBM)	 <p>-R1:10MΩ , R2:1.5KΩ , C:100pF</p>	5 times	0/5
On/Off test	50°C±3°C, 95%±2%RH, DC60 mA, On/2sec, Off/2sec	108000 cycles	0/50

2) Criteria for Judging the Damage

Item	Symbol	Test Condition	Limit	
			Min	Max
Forward Voltage	V_F	$I_F=60\text{mA}$, 30mA/die	-	U.S.L.*1.2
Luminous Intensity	IV	$I_F=60\text{mA}$, 30mA/die	L.S.L.*0.5	-
Reverse Current	I_R	$V_R=5\text{V}$	-	U.S.L.*2.0

* USL : Upper Standard Level LSL : Lower Standard Level

■ Solder Conditions

1) Reflow Conditions (Pb Free)

Reflow Frequency : 2 times max.

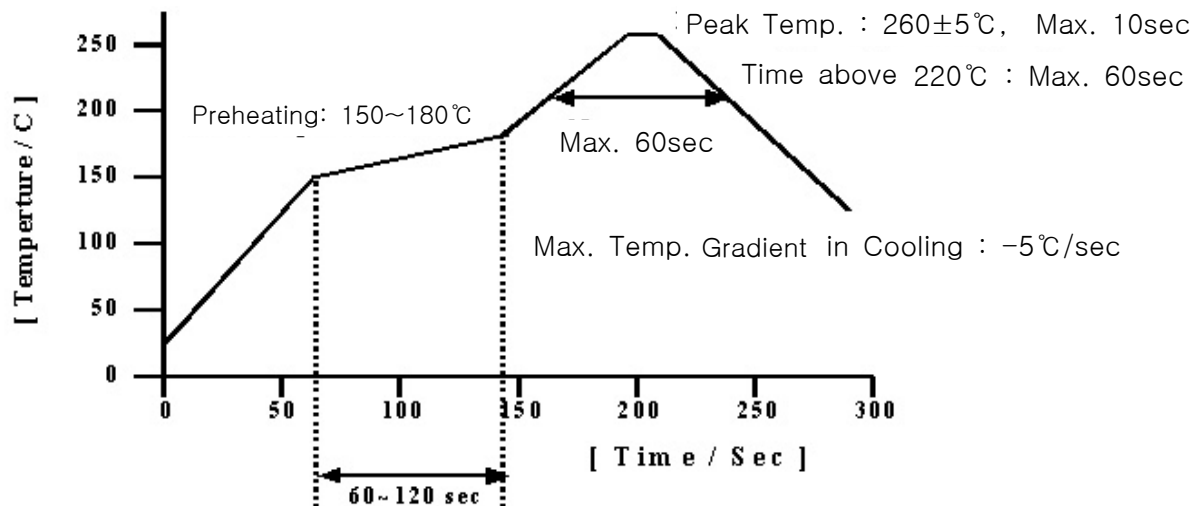

2) For Manual Soldering

Not more than 5 seconds @MAX 300°C , under soldering iron.

■ Taping Dimension

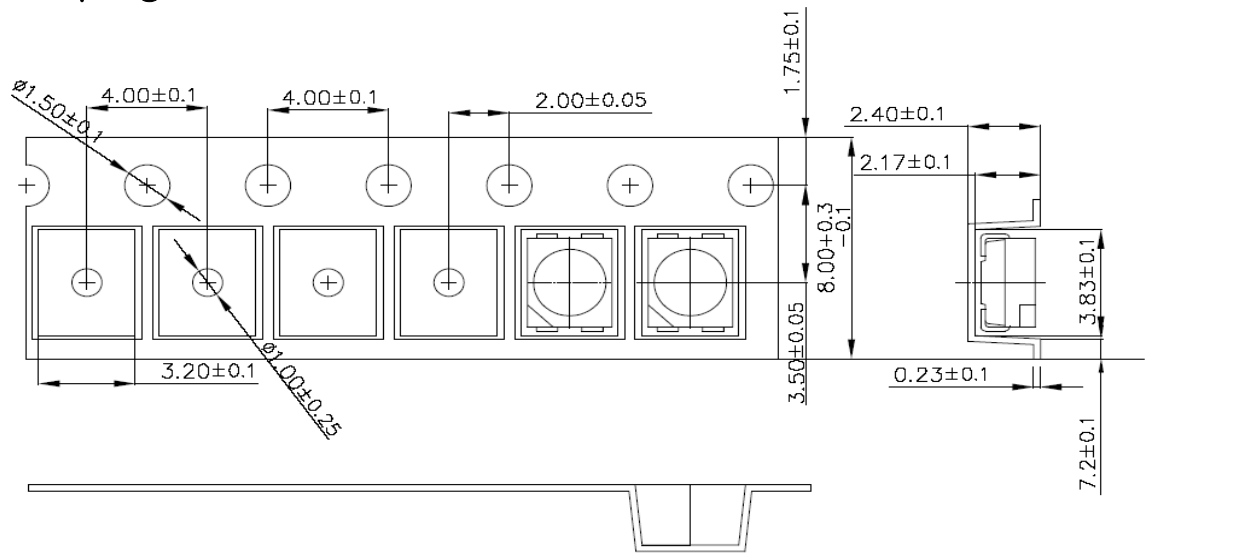

End

Start

More than 40 mm
Unloaded tape

Mounted with
Flash LED

More than (100~200)mm
Unloaded tape

Leading part more than
(200~400)mm

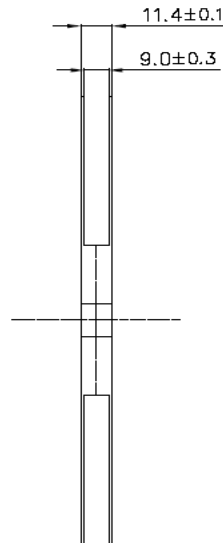
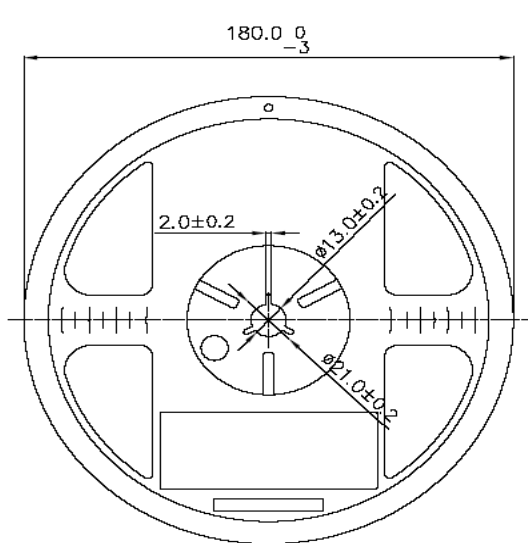

Tolerance ± 0.2 , Unit:mm

- (1) Quantity : The quantity/Reel to be 2000pcs.
- (2) Cumulative Tolerance : Cumulative tolerance/10 pitches to be ± 0.2 mm
- (3) Adhesion Strength of Cover Tape : Adhesion strength to be 0.1–0.7N when the cover tape is turned off from the carrier tape at 10°C angle to be the carrier tape.
- (4) Packaging : P/N, Manufacturing data code no. and quantity to be indicated on a damp proof Package.

■ Label Structure

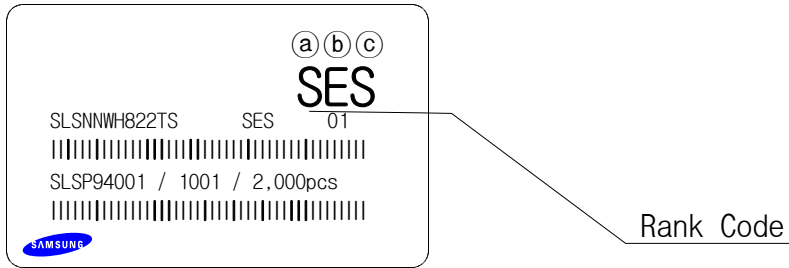

- Ⓐ : VF Rank
- Ⓑ : Chromaticity Coordinate Rank
- Ⓒ : IV Rank

■ Precaution for use

1. This device should not be used in any type of fluid such as water, oil, organic solvent, etc.
When washing is required, IPA should be used.
2. When the LEDs are illuminating, operating current should be decided after considering the ambient maximum temperature.
3. LEDs must be stored to maintain a clean atmosphere.
If the LEDs are stored for 3 months or more after being shipped from Samsung Electro-Mechanics, a sealed container with a nitrogen atmosphere should be used for storage.
4. The LEDs must be used within seven days after opening the moisture proof packing. Repack unused Products with anti-moisture packing, fold to close any opening and then store in a dry place.
5. The appearance and specifications of the product may be modified for improvement without notice.
6. This LEDs is sensitive to the static electricity and surge. It is recommended to use a wrist band or anti-electrostatic glove when handling the LEDs.

If over voltage which exceeds the absolute maximum rating is applied to LEDs, it will cause damage LEDs and result in destruction.

Damaged LEDs will show some unusual characteristics such as leak current remarkably increase, turn-on voltage becomes lower and the LEDs get unlighted at low current.

■ Hazard Substance Analysis



Test Report No. F690501/LF-CTSGP05-2792

Date: November 24, 2005

Page 1 of 2

To: SAMSUNG ELECTRO-MECHANICS CO., LTD.
314, Maetan3-dong
Yeongtong-gu
Suwon-city
KYUNGGI-DO 442-373
Korea

The following merchandise was submitted and identified by the client as :

Commodity : FLASH LED (3228-1.9T)
SGS File No. : GP05-2792
Received Date : November 17, 2005
Test Performing Date : November 18, 2005
Test Performed : SGS Testing Korea tested the sample(s) selected by applicant with following results
Test Results : For further details, please refer to following page(s)

Jeff Jang/Technical Mgr

SGS Testing Korea Co. Ltd.



Jason Han/Lab Director

This Test Report is issued by the Company subject to its General Conditions of Service printed overleaf. Attention is drawn to the limitations of liability, indemnification and jurisdictional issues defined therein. The results shown in this test report refer only to the sample(s) tested unless otherwise stated. This Test Report cannot be reproduced, except in full, without prior written permission of the Company.



Test Report No. F690501/LF-CTSGP05-2792

Date: November 24, 2005

Page 2 of 2

Sample No. : GP05-2792.001
Sample Description : FLASH LED (3228-1.9T)
Style/Item No. : N/A

Heavy Metals

Test Items	Unit	Test Method	MDL	Results
Cadmium(Cd)	mg/kg	USEPA 3050B, ICP-AES	0.5	N.D.
Lead (Pb)	mg/kg	USEPA 3050B, ICP-AES	5	N.D.
Mercury (Hg)	mg/kg	USEPA 3052, ICP-AES	2	N.D.
Hexavalent Chromium (Cr VI)	mg/kg	USEPA 3060A, UV-vis	1	N.D.

Flame Retardants-PBBs/PBDEs

Test Items	Unit	Test Method	MDL	Results
Monobromobiphenyl	mg/kg	USEPA 3540C, GC/MS	5	N.D.
Dibromobiphenyl	mg/kg	USEPA 3540C, GC/MS	5	N.D.
Tri bromobiphenyl	mg/kg	USEPA 3540C, GC/MS	5	N.D.
Tetrabromobiphenyl	mg/kg	USEPA 3540C, GC/MS	5	N.D.
Heptabromobiphenyl	mg/kg	USEPA 3540C, GC/MS	5	N.D.
Hexabromobiphenyl	mg/kg	USEPA 3540C, GC/MS	5	N.D.
Pentabromobiphenyl	mg/kg	USEPA 3540C, GC/MS	5	N.D.
Octabromobiphenyl	mg/kg	USEPA 3540C, GC/MS	5	N.D.
Nonabromobiphenyl	mg/kg	USEPA 3540C, GC/MS	5	N.D.
Decabromobiphenyl	mg/kg	USEPA 3540C, GC/MS	5	N.D.
Monobromobiphenyl ether	mg/kg	USEPA 3540C, GC/MS	5	N.D.
Dibromobiphenyl ether	mg/kg	USEPA 3540C, GC/MS	5	N.D.
Tri bromobiphenyl ether	mg/kg	USEPA 3540C, GC/MS	5	N.D.
Tetrabromobiphenyl ether	mg/kg	USEPA 3540C, GC/MS	5	N.D.
Heptabromobiphenyl ether	mg/kg	USEPA 3540C, GC/MS	5	N.D.
Hexabromobiphenyl ether	mg/kg	USEPA 3540C, GC/MS	5	N.D.
Pentabromobiphenyl ether	mg/kg	USEPA 3540C, GC/MS	5	N.D.
Octabromobiphenyl ether	mg/kg	USEPA 3540C, GC/MS	5	N.D.
Nonabromobiphenyl ether	mg/kg	USEPA 3540C, GC/MS	5	N.D.
Decabromobiphenyl ether	mg/kg	USEPA 3540C, GC/MS	5	N.D.

*** End ***

NOTE: N.D. = Not detected.(<MDL)
ppm = mg/kg
MDL = Method Detection Limit
"- " = No Regulation
" " = Qualitative analysis (No Unit)
Negative = Undetectable / Positive = Detectable

This Test Report is issued by the Company subject to its General Conditions of Service printed overleaf. Attention is drawn to the limitations of liability, indemnification and jurisdictional issues defined therein. The results shown in this test report refer only to the sample(s) tested unless otherwise stated. This Test Report cannot be reproduced, except in full, without prior written permission of the Company.

