



Product Specification			
	Model: GVIW50SNAL3E0	Rev. No.	Issued Date.
		A	2022/04/06
			Page.
			1 / 26

Thin-Film-Transistor LCD Module  
Model: GVIW50SNAL3E0

Acceptance

**Solomon Goldentek Display Corp.**  
**168,Fu Xiang Blvd,Di Yong Industrial Zone,**  
**Gao Bu,Dong Guan,Guang Dong 523273,China**  
**FAX: +86-769-8873-7947**

Approved and Checked by

Approved by	Checked by		Made by
			



Product Specification			
	Model: GVIW50SNAL3E0	Rev. No.	Issued Date.
		A	2022/04/06
		Page.	3 / 26

## Contents

<b>1</b>	<b>General Description and Features</b> .....	<b>4</b>
1.1	Features	4
1.2	LCD Module	4
<b>2</b>	<b>Mechanical Information</b> .....	<b>5</b>
<b>3</b>	<b>Electrical Specifications</b> .....	<b>6</b>
3.1	Absolute Max. Ratings	6
3.2	Electrical Absolute Rating	6
<b>4</b>	<b>Electrical Characteristics</b> .....	<b>7</b>
4.1	DC Characteristics	7
4.2	Backlight Unit	7
<b>5</b>	<b>Block Diagram</b> .....	<b>8</b>
<b>6</b>	<b>Input Terminal Pin Assignment</b> .....	<b>9</b>
<b>7</b>	<b>Optical Characteristics</b> .....	<b>11</b>
<b>8</b>	<b>Basic Display Color and Gray Scale</b> .....	<b>14</b>
<b>9</b>	<b>RGB Interface</b> .....	<b>15</b>
9.1	SYNC MODE	15
9.2	SYNC-DE Mode	16
9.3	DE Mode	17
9.4	Parallel 24-bit RGB Input Timing Table	18
<b>10</b>	<b>Timing table</b> .....	<b>19</b>
<b>11</b>	<b>Reliability Condition</b> .....	<b>21</b>
<b>12</b>	<b>Dimensional outlines</b> .....	<b>22</b>
<b>13</b>	<b>Incoming Inspection Standards</b> .....	<b>23</b>

## Product Specification

	Model: GVIW50SNAL3E0	Rev. No.	Issued Date.	Page.
		A	2022/04/06	4 / 26

### 1 General Description and Features

GVIW50SNAL3E0 is a color active matrix TFT (Thin Film Transistor) liquid crystal display (LCD) that uses amorphous silicon TFT as a switching device. This model is composed of a TFT-LCD module, a driver circuit and a back-light unit. The model has a 5.0 (5:3) inch diagonally measured active display area with 800X480 (800 horizontal by 480 vertical pixel) resolution. The following table described the features of GVIW50SNAL3E0.

#### 1.1 Features

- The back-light with 14 LEDs are available.
- IPS mode.
- Digital RGB (8 bits/color) data transfer.
- ROHS Compliance

#### 1.2 LCD Module

Item	Specification	Unit
Screen Size	5.0 inches	Diagonal
Display Resolution	800(H) x 480(V)	Pixel
Active Area	108 (H) x 64.8 (V)	mm
Outline Dimension	118.5(H) x77.55 (V) x 3.4 (T)	mm
Display Mode	Normally Black	--
Pixel Arrangement	RGB Vertical-Stripe	--
Pixel size	0.135 (H) x 0.135 (V)	mm
Surface Treatment	Anti-glare (AG)	--
Display Color	16.7M	--
Viewing Direction	ALL	--
Input Interface	Digital RGB (8 bits/color) Data Transfer	--

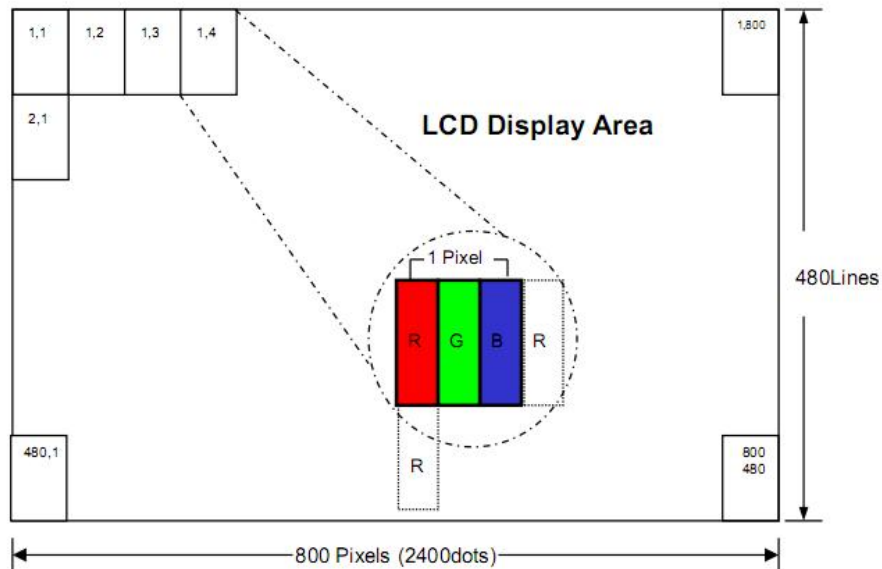

## Product Specification

	Model: GVIW50SNAL3E0	Rev. No.	Issued Date.	Page.
		A	2022/04/06	5 / 26

### 2 Mechanical Information

Item		Min.	Typ.	Max.	Unit	Note
Module Size	Horizontal (H)	118.35	118.5	118.65	mm	--
	Vertical (V)	77.40	77.55	77.70	mm	(1)
	Thickness (T)	3.2	3.4	3.6	mm	(1)
Weight		--	TBD	--	g	--

Note (1) Not include FPC.

Refer to the Outline Dimension Drawing as attached.

## Product Specification

	Model: GVIW50SNAL3E0	Rev. No.	Issued Date.	Page.
		A	2022/04/06	6 / 26

### 3 Electrical Specifications

#### 3.1 Absolute Max. Ratings

##### 3.1.1 Absolute Ratings of Environment

If the operating condition exceeds the following absolute maximum ratings, the TFT LCD module may be damaged permanently.

(Ta=25±2°C, V<sub>SS</sub>=GND=0)

Item	Symbol	Min.	Max.	Unit	Note
Storage temperature	T <sub>STG</sub>	-30	80	°C	(1)
Operating temperature	T <sub>OPR</sub>	-20	70	°C	(1,2,3)

Note (1) 95 % RH Max. ( 40 °C ≥ Ta ). Maximum wet-bulb temperature at 39 °C or less. (Ta > 40 °C) No condensation.

Note (2) In case of below 0°, the response time of liquid crystal (LC) becomes slower and the color of panel becomes darker than normal one. Level of retardation depends on temperature, because of LC's character

Note (3) Only operation is guaranteed at operating temperature. Contrast, response time, another display quality are evaluated at +25°C.

#### 3.2 Electrical Absolute Rating

##### 3.2.1 TFT-LCD Module

(Ta=25±2°C, V<sub>SS</sub>=GND=0)

Item	Symbol	Value		Unit	Condition
		Min.	Max.		
Power supply Voltage	V <sub>DD</sub>	-0.3	+4.0	V	--
IO Supply Voltage	V <sub>DDI</sub>	-0.3	+4.0	V	
Charge Pump Supply Voltage	PV <sub>DD</sub>	-0.3	+4.0	V	
Enhance Charge Pump Supply Voltage	PV <sub>DD1</sub>	-0.3	+4.0	V	
Logic input voltage Range	V <sub>IN</sub>	-0.3	V <sub>DDI</sub> +0.3	V	--
Logic output voltage Range	V <sub>OUT</sub>	-0.3	V <sub>DDI</sub> +0.3	V	

##### 3.2.2 Back-Light Unit

(Ta=25±2°C)

Item	Symbol	Min.	Max.	Unit	Note
Current of One LED	I <sub>B</sub>	--	(25)	mA	(1)

Note (1) Permanent damage to the device may occur if maximum values are exceeded or reverse voltage is loaded. Functional operation should be restricted to the conditions described under normal operating conditions.

## Product Specification

	Model: GVIW50SNAL3E0	Rev. No.	Issued Date.	Page.
		A	2022/04/06	7 / 26

### 4 Electrical Characteristics

#### 4.1 DC Characteristics

Recommended Operating Range

DC Electrical Characteristics (PVDD=PVDD1=VDD=VDDI= 3.3V, AGND= 0V, TA=25°C, Bare Chip)

Item	Symbol	Value			Unit	Note
		Min.	Typ.	Max.		
Supply Voltage	VDD	3.1	3.3	3.6	V	
IO Supply Voltage	VDDI	3.1	3.3	3.6	V	
Charge Pump Supply Voltage	PVDD	3.1	3.3	3.6	V	
Enhance Charge Pump Supply Voltage	PVDD1	3.1	3.3	3.6	V	

DC Characteristics for Digital Circuit

DC Electrical Characteristics (PVDD=PVDD1=VDD=VDDI= 3.3V, AGND= 0V, TA=25°C, Bare Chip)

Item	Symbol	Value			Unit	Note
		Min.	Typ.	Max.		
Logic-High Input Voltage	VIH	0.7VDDI	-	VDDI	V	
Logic-Low Input Voltage	VIL	DGND	-	0.3 VDDI	V	
Logic-High Output Voltage	Voh	VDDI-0.4	-	VDDI	V	
Logic-Low Output Voltage	Vol	DGND	-	DGND+0.4	v	

#### 4.2 Backlight Unit

The back-light system is an edge-lighting type with white LED (Light Emitting Diode)s.

(Ta=25±2°C)

Item	Symbol	Value			Unit	Condition
		Min.	Typ.	Max.		
LED Voltage	VL	21.0	22.4	23.8	V	
LED Current	If	-	40		mA	
Power Consumption	P <sub>LED</sub>	-	896		mW	
LED Life Time (25°C)	-	35000	50000	-	hr	

Note (1)14 LEDs serial type.

(2) Where  $I_f = 40\text{mA}$ ,  $V_L = 22.4\text{V}$ ,  $P_{LED} = V_L \times I_f$

(3)The environmental conducted under ambient air flow, at Ta=25±2°C,60%RH±5%



## Product Specification



Model: GVIW50SNAL3E0

Rev. No.

Issued Date.

Page.

A

2022/04/06

8 / 26

### 5 Block Diagram

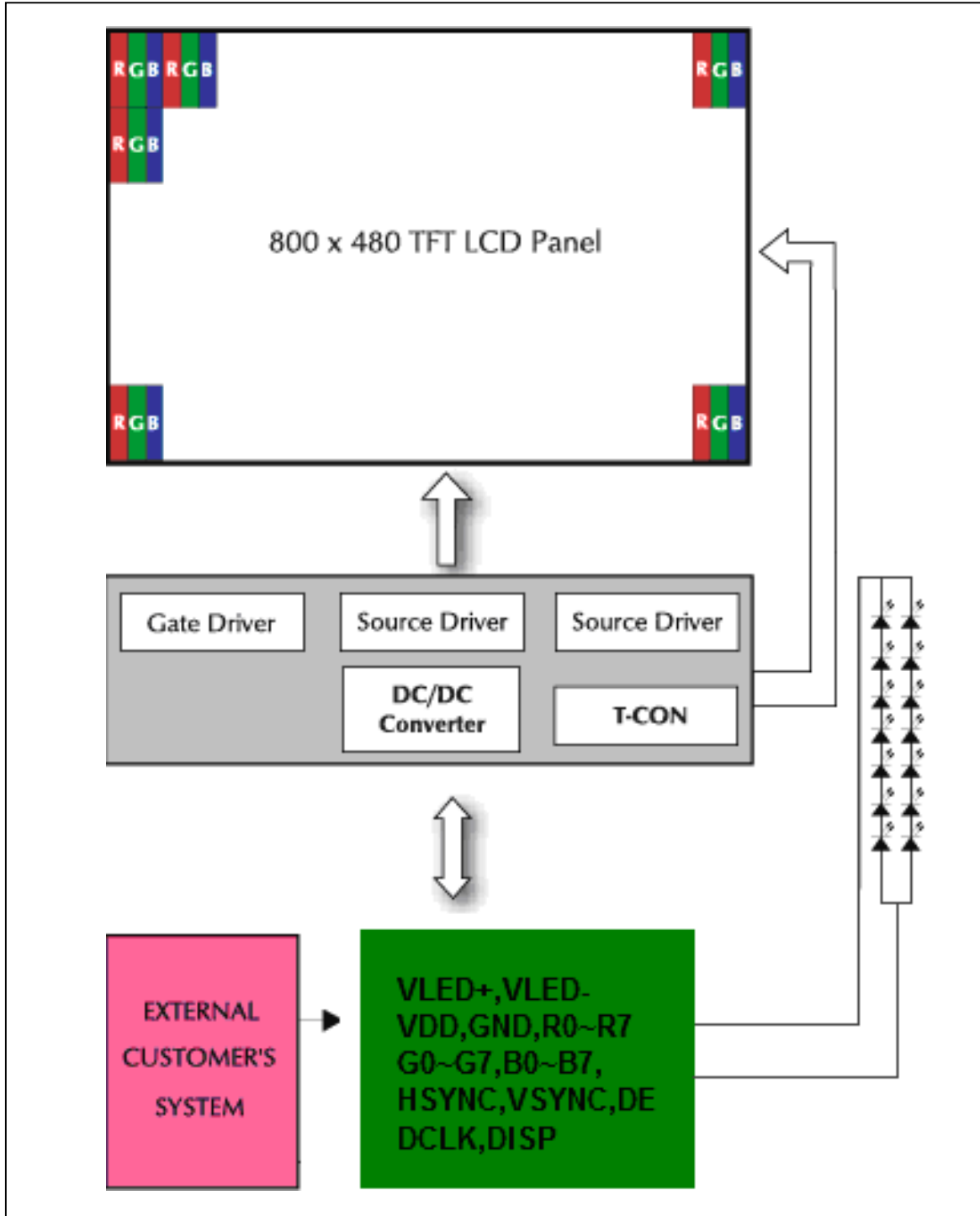

## Product Specification

	Model: GVIW50SNAL3E0	Rev. No.	Issued Date.	Page.
		A	2022/04/06	9 / 26

### 6 Input Terminal Pin Assignment

#### 6.1 CN1 Pin Assignment

Pin No.	Symbol	I/O	Function	Remark
1	VLED-	P	Power for LED backlight cathode	
2	VLED+	P	Power for LED backlight anode	
3	GND	P	Power Ground	
4	VDD	P	Power Supply	
5	R0	I	Red data signal (LSB)	
6	R1	I	Red data signal	
7	R2	I	Red data signal	
8	R3	I	Red data signal	
9	R4	I	Red data signal	
10	R5	I	Red data signal	
11	R6	I	Red data signal	
12	R7	I	Red data signal (MSB)	
13	G0	I	Green data signal (LSB)	
14	G1	I	Green data signal	
15	G2	I	Green data signal	
16	G3	I	Green data signal	
17	G4	I	Green data signal	
18	G5	I	Green data signal	
19	G6	I	Green data signal	
20	G7	I	Green data signal (MSB)	
21	B0	I	Blue data signal (LSB)	
22	B1	I	Blue data signal	
23	B2	I	Blue data signal	
24	B3	I	Blue data signal	
25	B4	I	Blue data signal	
26	B5	I	Blue data signal	
27	B6	I	Blue data signal	
28	B7	I	Blue data signal (MSB)	
29	DGND	P	Digital ground	
30	DCLK	I	Pixel clock	
31	DISP	I	Display on/ off	
32	HSYNC	I	Horizontal sync signal	
33	VSYNC	I	Vertical sync signal	

## Product Specification



Model: GVIW50SNAL3E0

Rev. No.

Issued Date.

Page.

A

2022/04/06

10 / 26

34	DE	I	Data Enable signal	
35	NC	I	No Connect	
36	GND	P	Power Ground	
37	NC	-	No Connect	
38	NC	-	No Connect	
39	NC	-	No Connect	
40	NC	-	No Connect	

I: Input, O: Output, P: Power

Notes:

- 1) NC Pin must be retained; this pin can't contact GND or other signal.
- 2) GND Pin must ground contact, can not be floating.
- 3) Connector Part No: FH12A-40S-0.5SH(55) or equivalent.

## Product Specification

	Model: GVIW50SNAL3E0	Rev. No.	Issued Date.	Page.
		A	2022/04/06	11 / 26

### 7 Optical Characteristics

The following items are measured under stable conditions. The optical characteristics should be measured in a dark room

Measuring equipment: BM-7A

(Ta=25±2°C , VDD =3.3V, I<sub>f</sub>=40mA)

Item		Symbol	Condition	Min	Type	Max	Unit	Note
Brightness		--	--	700	800	--	cd/m <sup>2</sup>	--
Response time		T <sub>on+</sub> T <sub>off</sub>	θ=0°	--	30	40	ms	--
Contrast ratio		CR	At optimized viewing angle	800	1000	--	--	--
Color Chromaticity	Red	R <sub>x</sub>	θ=0° Normal Viewing Angle	(0.538)	(0.588)	(0.638)	--	--
		R <sub>y</sub>		(0.276)	(0.326)	(0.376)		
	Green	G <sub>x</sub>		(0.315)	(0.365)	(0.415)	--	
		G <sub>y</sub>		(0.536)	(0.586)	(0.636)		
	Blue	B <sub>x</sub>		(0.086)	(0.136)	(0.186)	--	
		B <sub>y</sub>		(0.060)	(0.110)	(0.160)		
	White	W <sub>x</sub>		(0.250)	(0.300)	(0.350)	--	
		W <sub>y</sub>		(0.270)	(0.320)	(0.370)		
Viewing Angle (6H)	Hor.	θ <sub>R</sub>	CR≥10	70	80	Degree	--	
		θ <sub>L</sub>		70	80			
	Ver.	θ <sub>U</sub>		70	80			
		θ <sub>D</sub>		70	80			

## Product Specification

	Model: GVIW50SNAL3E0	Rev. No.	Issued Date.	Page.
		A	2022/04/06	12 / 26

a. Test equipment setup

After stabilizing and leaving the panel alone shall be warmed up for the stable operation of LCM, the measurement should be executed. Measurement should be executed in a stable, windless, and dark room. Optical specifications are measured by Topcon BM-5A/BM-7(fast) with a viewing angle of 2° at a distance of 50cm and normal direction.

b. Definition of response time: Tr and Tf

The response time is defined as the following figure and shall be measured by switching the input signal for "black" and "white".

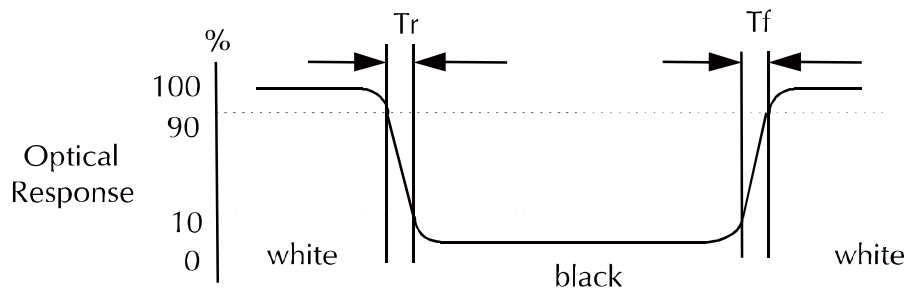

c. Definition of contrast ratio:

$$\text{Contrast Ratio (CR)} = \frac{\text{Brightness measured when LCD is at "white state"}}{\text{Brightness measured when LCD is at "black state"}}$$

d. Measured at the center area of the panel when all the input terminals of LCD panel are electrically opened.

## Product Specification

	Model: GVIW50SNAL3E0	Rev. No.	Issued Date.	Page.
		A	2022/04/06	13 / 26

e. View Angle

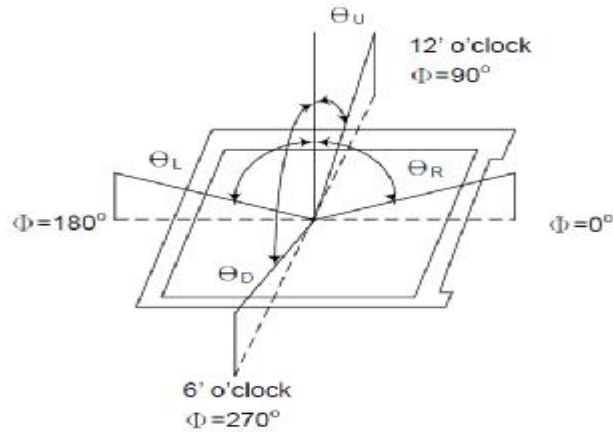

f. Definition of Luminance of White: Luminance of white at the center points

Light Source of Back-Light Unit	LED Type
---------------------------------	----------

g. Definition of White Uniformity

$$\text{White Uniformity} = \frac{\text{Min. luminance of white among 9-points}}{\text{Max. luminance of white among 9-points}} \times 100\%$$

h. The definition of Color Gamut -Color Chromaticity CIE 1931

Color coordinate of white & red, green, blue at center point.

$$\text{Color Gamut : NTSC(\%)} = (\text{RGB Triangle Area} / \text{NTSC Triangle Area}) \times 100$$

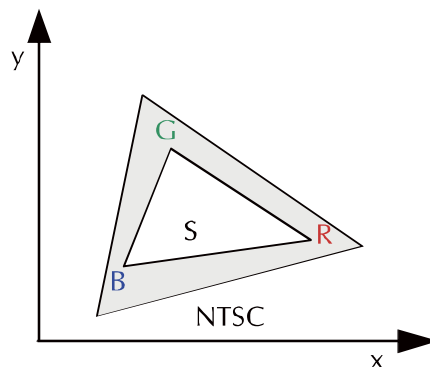

## Product Specification

	Model: GVIW50SNAL3E0	Rev. No.	Issued Date.	Page.
		A	2022/04/06	14 / 26

### 8 Basic Display Color and Gray Scale

	Color & Gray Scale	Data Signal																							
		R7	R6	R5	R4	R3	R2	R1	R0	G7	G6	G5	G4	G3	G2	G1	G0	B7	B6	B5	B4	B3	B2	B1	B0
Basic Color	Black	0	0	0	0	0	0	0	0	0	0	0	0	0	0	0	0	0	0	0	0	0	0	0	0
	Red(0)	1	1	1	1	1	1	1	1	0	0	0	0	0	0	0	0	0	0	0	0	0	0	0	0
	Green(0)	0	0	0	0	0	0	0	0	1	1	1	1	1	1	1	1	0	0	0	0	0	0	0	0
	Blue(0)	0	0	0	0	0	0	0	0	0	0	0	0	0	0	0	0	1	1	1	1	1	1	1	1
	Cyan	0	0	0	0	0	0	0	0	1	1	1	1	1	1	1	1	1	1	1	1	1	1	1	1
	Magenta	1	1	1	1	1	1	1	1	0	0	0	0	0	0	0	0	1	1	1	1	1	1	1	1
	Yellow	1	1	1	1	1	1	1	1	1	1	1	1	1	1	1	1	0	0	0	0	0	0	0	0
	White	1	1	1	1	1	1	1	1	1	1	1	1	1	1	1	1	1	1	1	1	1	1	1	1
Red	Black	0	0	0	0	0	0	0	0	0	0	0	0	0	0	0	0	0	0	0	0	0	0	0	
	Red(1)	0	0	0	0	0	0	0	1	0	0	0	0	0	0	0	0	0	0	0	0	0	0	0	
	Red(2)	0	0	0	0	0	0	1	0	0	0	0	0	0	0	0	0	0	0	0	0	0	0	0	
	:	:	:	:	:	:	:	:	:	:	:	:	:	:	:	:	:	:	:	:	:	:	:	:	
	Red(127)	0	1	1	1	1	1	1	1	0	0	0	0	0	0	0	0	0	0	0	0	0	0	0	
	:	:	:	:	:	:	:	:	:	:	:	:	:	:	:	:	:	:	:	:	:	:	:	:	
	Red(254)	1	1	1	1	1	1	1	0	0	0	0	0	0	0	0	0	0	0	0	0	0	0	0	
	Red(255)	1	1	1	1	1	1	1	1	0	0	0	0	0	0	0	0	0	0	0	0	0	0	0	
Green	Black	0	0	0	0	0	0	0	0	0	0	0	0	0	0	0	0	0	0	0	0	0	0	0	
	Green(1)	0	0	0	0	0	0	0	0	0	0	0	0	0	0	1	0	0	0	0	0	0	0	0	
	Green(2)	0	0	0	0	0	0	0	0	0	0	0	0	0	1	0	0	0	0	0	0	0	0	0	
	:	:	:	:	:	:	:	:	:	:	:	:	:	:	:	:	:	:	:	:	:	:	:	:	
	Green(127)	0	0	0	0	0	0	0	0	0	1	1	1	1	1	1	1	0	0	0	0	0	0	0	
	:	:	:	:	:	:	:	:	:	:	:	:	:	:	:	:	:	:	:	:	:	:	:	:	
	Green(254)	0	0	0	0	0	0	0	0	1	1	1	1	1	1	1	0	0	0	0	0	0	0	0	
	Green(255)	0	0	0	0	0	0	0	0	1	1	1	1	1	1	1	1	0	0	0	0	0	0	0	
Blue	Black	0	0	0	0	0	0	0	0	0	0	0	0	0	0	0	0	0	0	0	0	0	0	0	
	Blue(1)	0	0	0	0	0	0	0	0	0	0	0	0	0	0	0	0	0	0	0	0	0	0	1	
	Blue(2)	0	0	0	0	0	0	0	0	0	0	0	0	0	0	0	0	0	0	0	0	0	1	0	
	:	:	:	:	:	:	:	:	:	:	:	:	:	:	:	:	:	:	:	:	:	:	:	:	
	Blue(127)	0	0	0	0	0	0	0	0	0	0	0	0	0	0	0	0	0	1	1	1	1	1	1	
	:	:	:	:	:	:	:	:	:	:	:	:	:	:	:	:	:	:	:	:	:	:	:	:	
	Blue(254)	0	0	0	0	0	0	0	0	0	0	0	0	0	0	0	0	1	1	1	1	1	1	0	
	Blue(255)	0	0	0	0	0	0	0	0	0	0	0	0	0	0	0	0	1	1	1	1	1	1	1	

0 : Low level voltage, 1 : High level voltage

Each basic color can be displayed in 256 gray scales from 8 bit data signals. With the combination of total 24 bit data signals, the 16,7M-color display can be achieved on the screen.

# Product Specification



Model: GVIW50SNAL3E0

Rev. No.

Issued Date.

Page.

A

2022/04/06

15 / 26

## 9 RGB Interface

RGB Mode Selection Table	DCLK	HSYNC	VSYNC	DE
SYNC - DE Mode	Input	Input	Input	Input
SYNC Mode	Input	Input	Input	GND
DE Mode	Input	GND	GND	Input

### 9.1 SYNC MODE

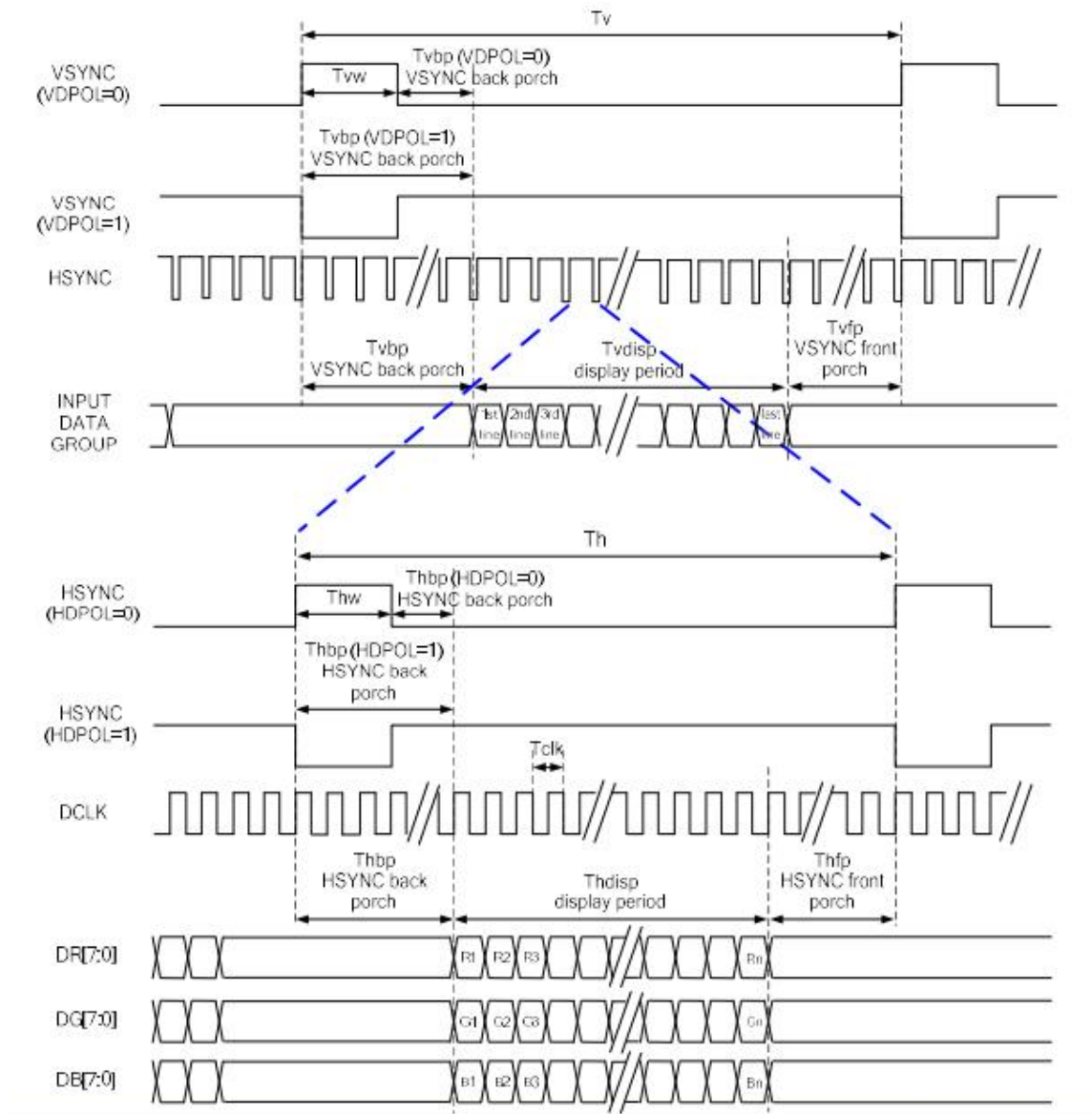

# Product Specification

	Model: GVIW50SNAL3E0	Rev. No.	Issued Date.	Page.
		A	2022/04/06	16 / 26

## 9.2 SYNC-DE Mode

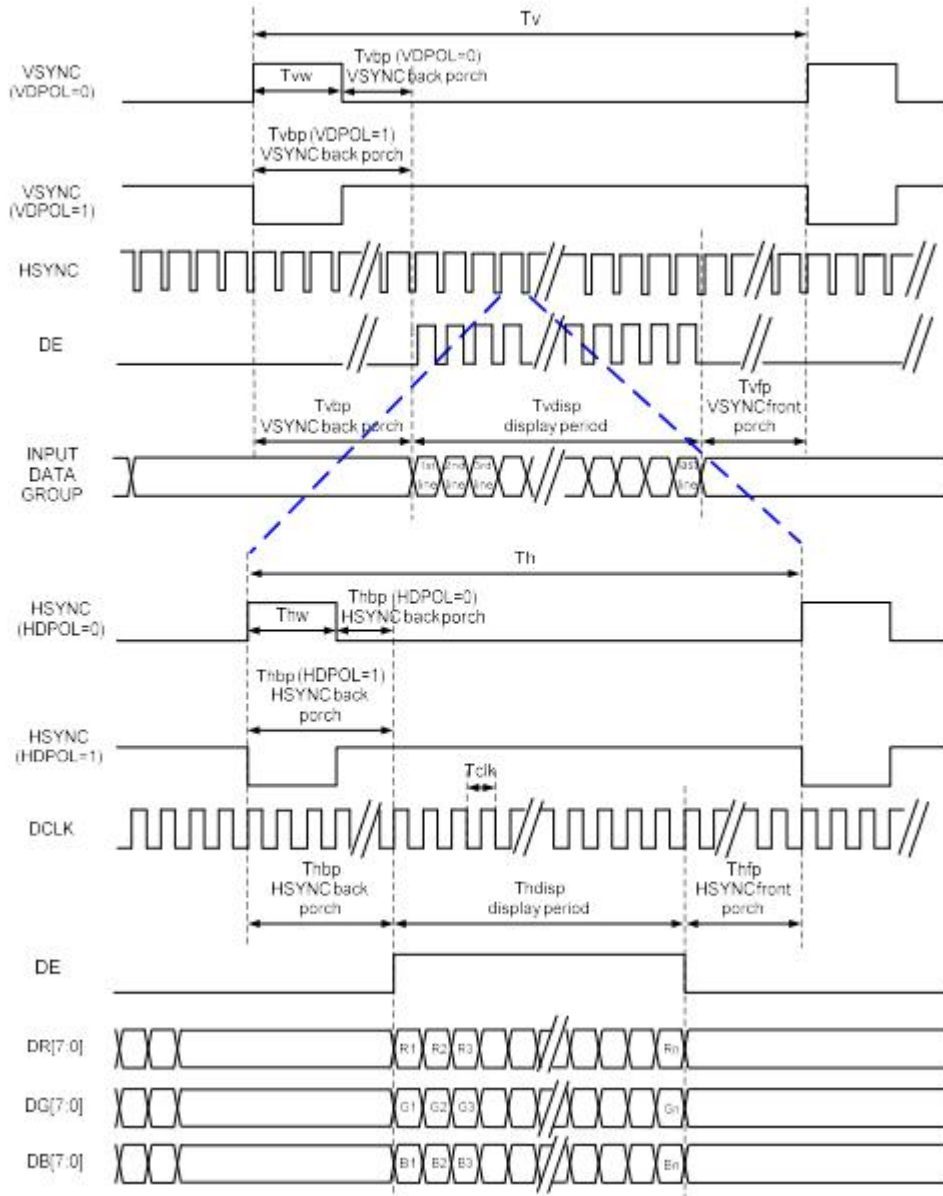

# Product Specification

	Model: GVIW50SNAL3E0	Rev. No.	Issued Date.	Page.
		A	2022/04/06	17 / 26

## 9.3 DE Mode

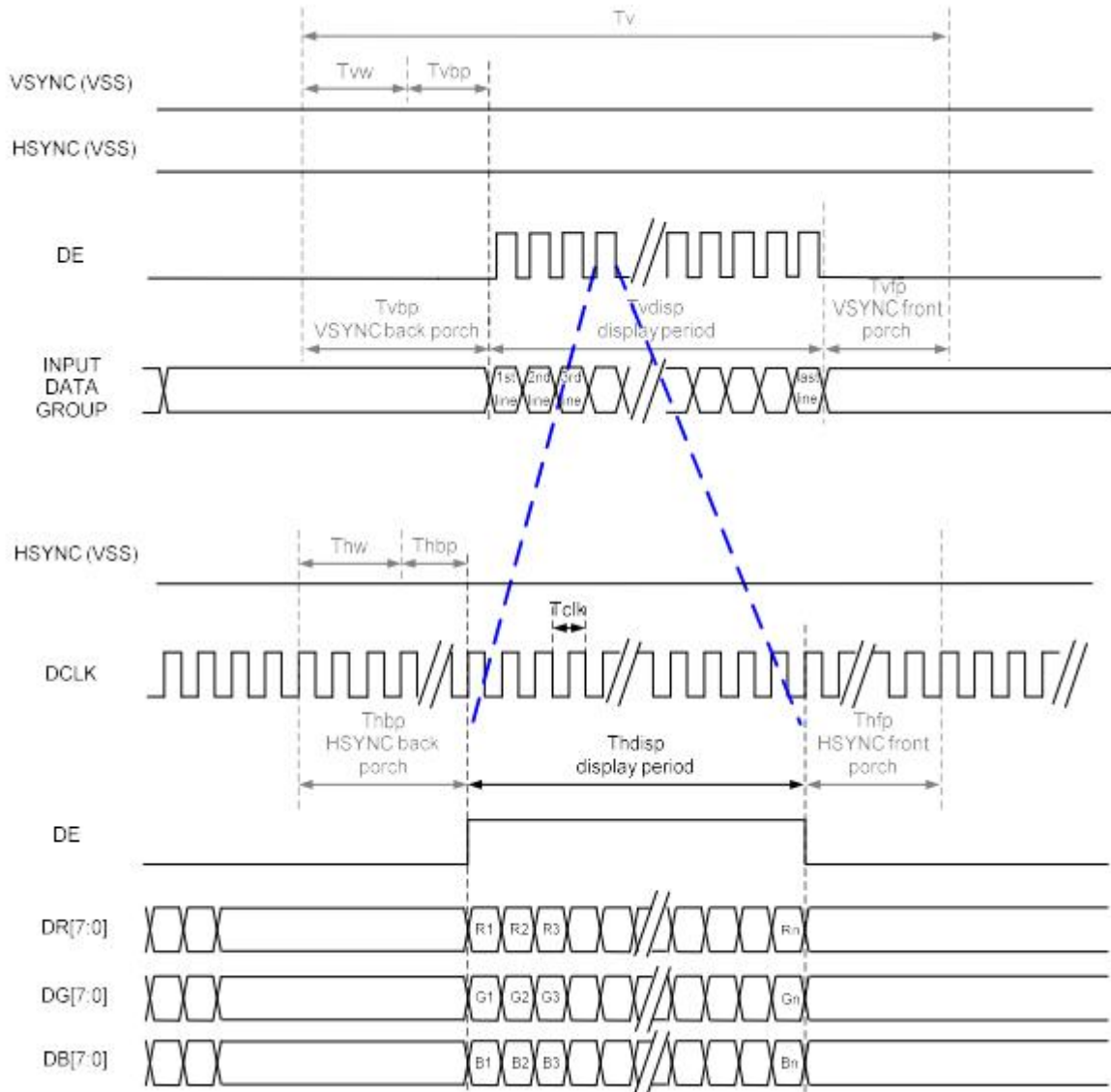

## Product Specification

	Model: GVIW50SNAL3E0	Rev. No.	Issued Date.	Page.
		A	2022/04/06	18 / 26

### 9.4 Parallel 24-bit RGB Input Timing Table

Parallel 24-bit RGB Input Timing (PVDD=PVDD1=VDD=VDDI= 3.3V, AGND= 0V, TA=25°C)

Parallel 24-bit RGB Interface Timing Table							
Item	Symbol	Min.	Typ.	Max.	Unit	Remark	
DCLK Frequency		Fclk	23	25	27	MHz	
HSYNC	Period Time	Th	808	816	896	DCLK	
	Display Period	Thdisp	800			DCLK	
	Back Porch	Thbp	4	8	48	DCLK	
	Front Porch	Thfp	4	8	48	DCLK	
	Pulse Width	Thw	2	4	8	DCLK	
VSYNC	Period Time	Tv	492	496	504	HSYNC	
	Display Period	Tvdisp	480			HSYNC	
	Back Porch	Tvbp	6	8	12	HSYNC	
	Front Porch	Tvfp	6	8	12	HSYNC	
	Pulse Width	Tvw	2	4	8	HSYNC	

- Note: 1. The minimum blanking time depends on the GIP timing of the panel specification  
 2. To ensure the compatibility of different panels, it is recommended to use the typical setting.

# Product Specification



Model: GVIW50SNAL3E0

Rev. No.

Issued Date.

Page.

A

2022/04/06

19 / 26

## 10 Timing table

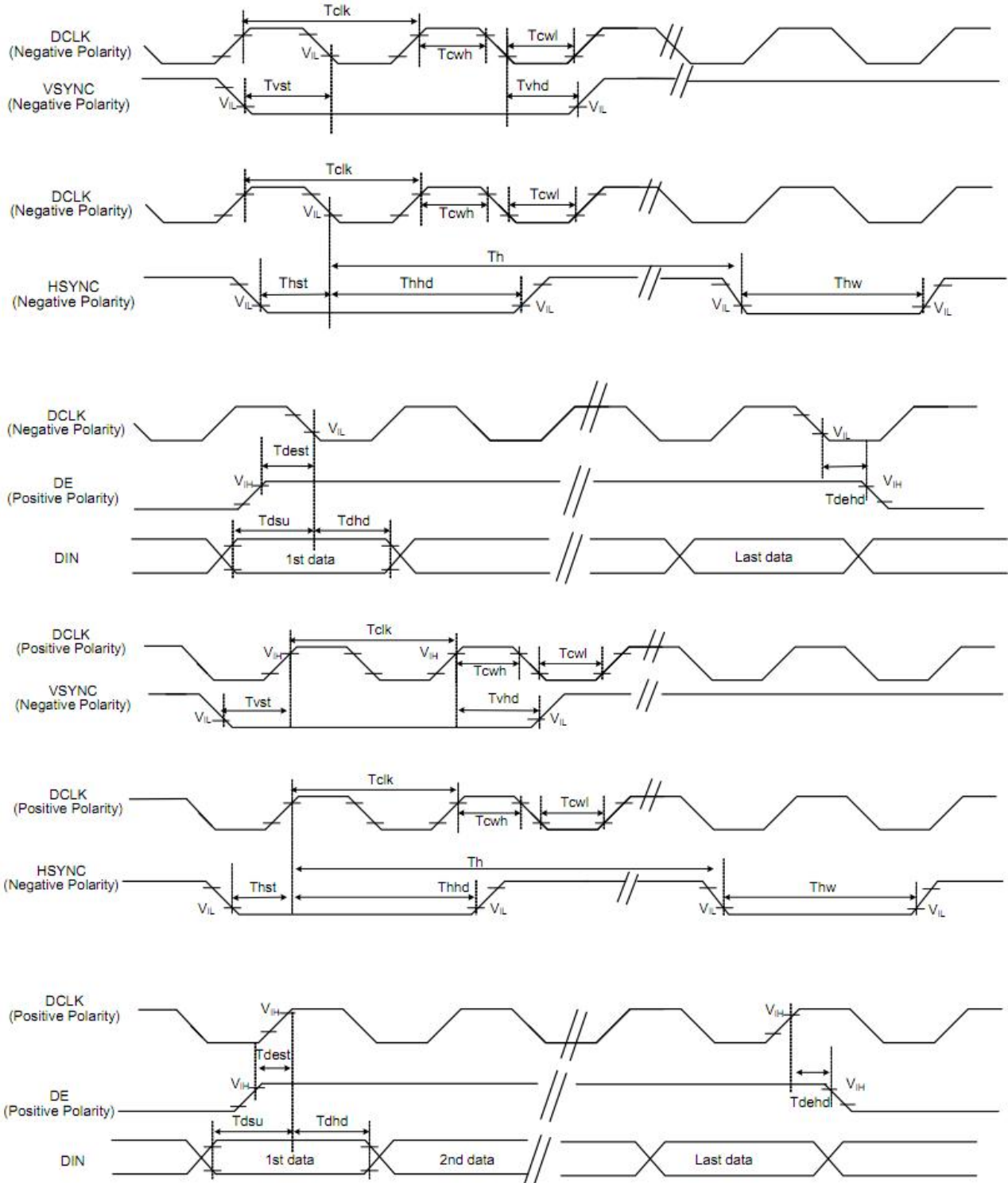

## Product Specification



Model: GVIW50SNAL3E0

Rev. No.

Issued Date.

Page.

A

2022/04/06

20 / 26

Item	Symbol	Min.	Typ.	Max.	Unit	Conditions
CLK Pulse Duty	Tclk	40	50	60	%	
VSYNC Setup Time	Tvst	10	-	-	ns	
VSYNC Hold Time	Tvhd	10	-	-	ns	
HSYNC Setup Time	Thst	10	-	-	ns	
HSYNC Hold Time	Thhd	10	-	-	ns	
Data Setup Time	Tdsu	10	-	-	ns	
Data Hold Time	Tdhd	10	-	-	ns	
DE Setup Time	Tdest	10	-	-	ns	
DE Hold Time	Tdehd	10	-	-	ns	

## Product Specification

	Model: GVIW50SNAL3E0	Rev. No.	Issued Date.	Page.
		A	2022/04/06	21 / 26

### 11 Reliability Condition

No change on display and in operation under the following test condition.

Condition: Unless otherwise specified, tests will be conducted under the following condition.

Temperature: 20±5°C.

Humidity: 65±5%RH.

Tests will be not conducted under functioning state.

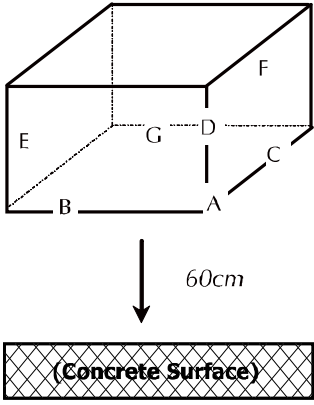
No.	Parameter	Condition	Notes
1	High Temperature Operating	70°C±2°C, 240hrs (Operation state).	
2	Low Temperature Operating	-20°C±2°C, 240hrs (Operation state).	1
3	High Temperature Storage	80°C±2°C, 240hrs.	2
4	Low Temperature Storage	-30°C±2°C, 240hrs.	1,2
5	High Temperature and High Humidity Operation Test	60°C±2°C, 90%, 240hrs	1,2
6	Vibration Test	Total fixed amplitude: 1.5mm. Vibration Frequency: 10~55Hz. One cycle 60 seconds to 3 direction of X, Y, Z each 15 minutes.	3
7.	Drop Test	To be measured after dropping from 60cm high on the concrete surface in packing state.   <div style="margin-left: 20px;"> <p><i>Dropping method corner dropping:</i></p> <p><i>A corner: Once edge dropping.</i></p> <p><i>B, C, D edge: Once face dropping.</i></p> <p><i>E, F, G face: Once.</i></p> </div>	

# Product Specification



Model: GVIW50SNAL3E0

Rev. No.

Issued Date.

Page.

A

2022/04/06

22 / 26

## 12 Dimensional outlines

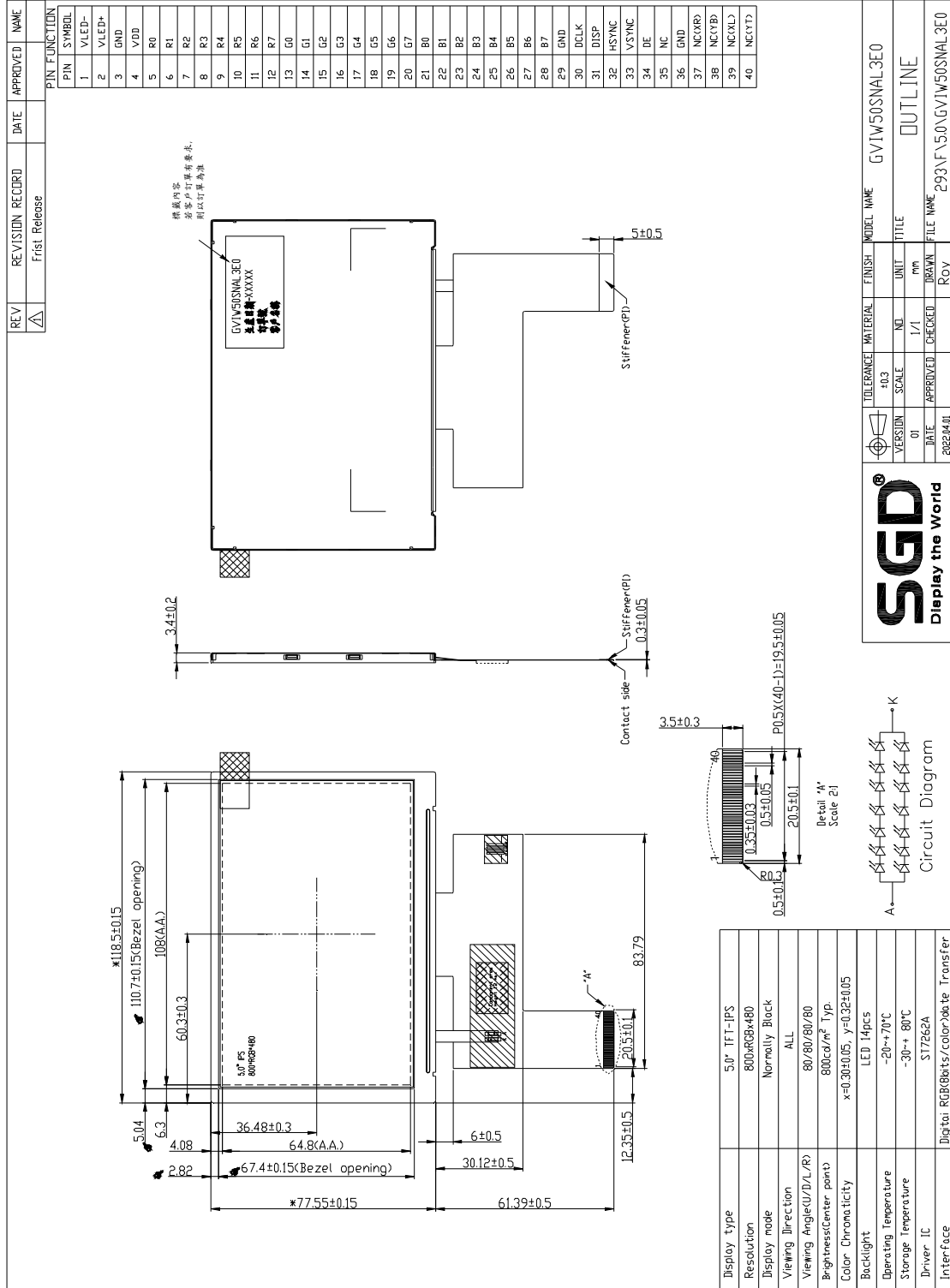

## Product Specification

	Model: GVIW50SNAL3E0	Rev. No.	Issued Date.	Page.
		A	2022/04/06	23 / 26

### 13 Incoming Inspection Standards

#### 13.1 Inspection and Environment Conditions

##### 13.1.1 Inspection Conditions:

- (1) Inspection Distance: 35 cm $\pm$ 5cm
- (2) View Angle : Light-on Inspection Angle :  $\pm 5^\circ$

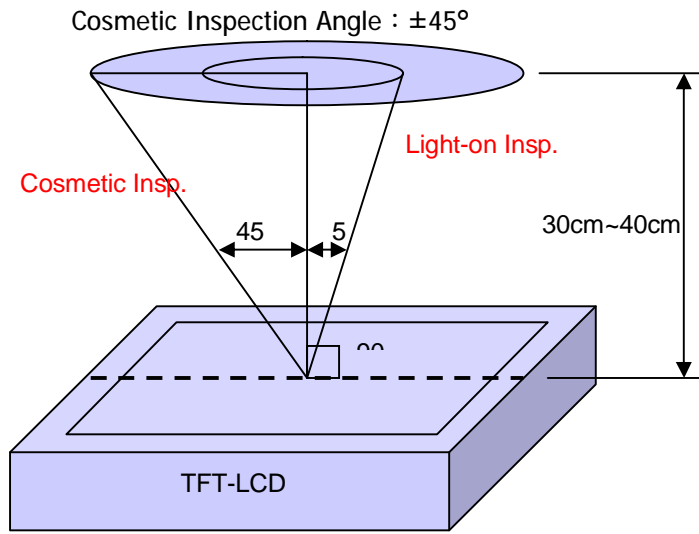

( perpendicular to LCD panel surface)

##### 13.1.2 Environment Conditions:

Ambient Temperature		23°C $\pm$ 5°C
Ambient Humidity		55 $\pm$ 10%RH
Ambient Illumination	Cosmetic Inspection	more than 600 Lux
	Functional Inspection	300~500 Lux

##### 13.1.3 Sampling Conditions:

- (1) Lot Size: Quantity of shipment lot per model
- (2) Sampling Method:

Sampling Plan		MIL-STD-105E
		Normal Inspection, Single Sampling
		Level II
AQL	Major Defect	1.0%
	Minor Defect	1.5%

- (3) The classification of Major(MA) and Minor(MI) defects is shown as 3. Inspection Criteria.

## Product Specification

	Model: GVIW50SNAL3E0	Rev. No.	Issued Date.	Page.
		A	2022/04/06	24 / 26

### 13.1.4 Inspection Criteria

#### 13.1.4.1 Cosmetic Inspection(Panel):

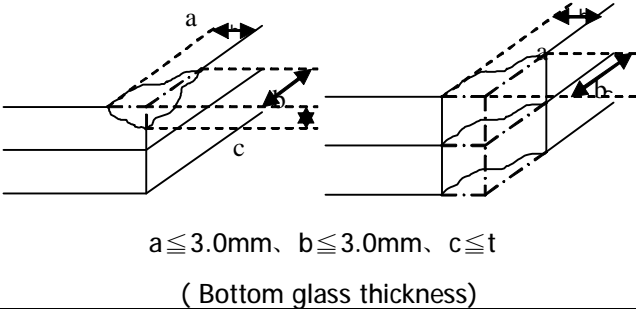
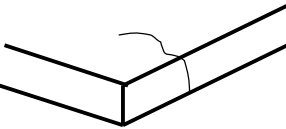
Item	Judgment Criteria	Classification
Chipping on Panel	 <p style="text-align: center;"> <math>a \leq 3.0\text{mm}</math>、<math>b \leq 3.0\text{mm}</math>、<math>c \leq t</math>                      ( Bottom glass thickness)                 </p>	MA
Scratch on Panel *Note-2	$W \leq 0.05\text{mm}$ or $L < 5\text{mm}$ : Ignored $0.05\text{mm} < W \leq 0.1\text{mm}$ and $L \leq 5\text{mm}$ : $N \leq 5$ $W > 0.1\text{mm}$ or $L > 5\text{mm}$ : Not allowed	MI
Bubble or Dent on Panel *Note-3	$D \leq 0.2\text{mm}$ : Ignored $0.2\text{mm} < D \leq 0.3\text{mm}$ : $N \leq 5$ $D > 0.3\text{mm}$ : Not allowed	MI
Panel Crack	 <p style="text-align: center;">Not Allowed crack</p>	MA
Bezel Deformation	Obvious deformation is not allowed.	MI
Bezel Oxidation	Not allowed if it rusts continuously over 1 cm (It is out of warranty with rusted tin plate)	MI
Bezel Scratch	$L \leq 20\text{mm}$ , $W \leq 0.2$ , $N \leq 3$	MI
Metal Squash Dent /Flange(Front Side)	$D(W) \leq 1, L \leq 3, N \leq 3$ ;	MI
B/L High Voltage Wire Denudation	Not allowed	MA
Polarizer flaw or leak out resin	Defect is defined as the active area.	MI

## Product Specification

	Model: GVIW50SNAL3E0	Rev. No.	Issued Date.	Page.
		A	2022/04/06	25 / 26

Outline Dimension	Must in Spec, refer to related product spec.	MI
-------------------	--	----

### 13.1.4.2 Functional Inspection:

Item	Judgment Criteria			Classification
	Area(Note1)	I	O	
Point Defect	Bright dot	Random	2	
		2 dots adjacent	0	0
		3 dots adjacent or more	0	0
	Dark dot	Random	3	
		2 dots adjacent	0	
		3 dots adjacent or more	0	0
	Total Dot Defect		5	
	Distance	Distance between Bright and Bright dot	$L \geq 5\text{mm}$	
		Distance between Bright and Dark dot	$L \geq 5\text{mm}$	
		Distance between Dark dot	$L \geq 5\text{mm}$	
(1) It is defined as Point Defect if defect area $> 0.5\text{dot}$ (2) It is ignored if defect area $\leq 0.5\text{dot}$ (3) Weak point defect will be defined as Bright Dot if it can be observed through ND filter 5%( Full Screen Black Inspection)				
Line Defect	Obvious vertical or horizontal line defect is not allowed.			MA
Mura	Not allowed if it can be observed through ND Filter 5 %			MI
Foreign Material in spot shape *Note-3	$D \leq 0.2\text{mm}$ : Ignored $0.2\text{mm} < D \leq 0.5\text{mm}$ : $N \leq 8$ $D > 0.5\text{mm}$ : Not allowed			MI
Foreign Material in line or spiral shape *Note-4	$W \leq 0.05\text{mm}$ or $L \leq 5\text{mm}$ : Ignored $0.05\text{mm} < W \leq 0.2\text{mm}$ and $L 1.0\text{mm} \leq 5\text{mm}$ : $N \leq 8$ $W > 0.2\text{mm}$ or $L > 5\text{mm}$ : Not allowed			MI
Display Function Abnormal	No Malfunction can be allowed			MA

# Product Specification

	Model: GVIW50SNAL3E0	Rev. No.	Issued Date.	Page.
		A	2022/04/06	26 / 26

Note-1 : I/O Area Definition

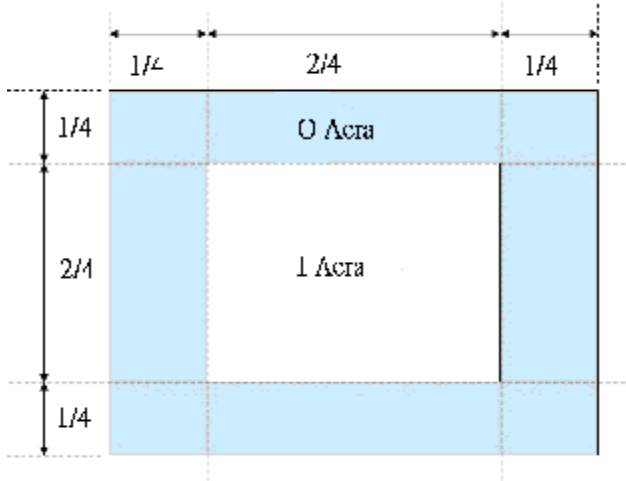

Note-2 : Polarizer Scratch

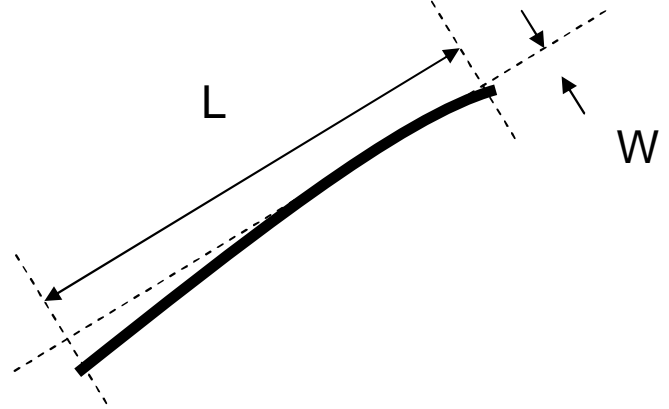

Note-3 : Spot Foreign Material  
( $W \geq L / 4$ )

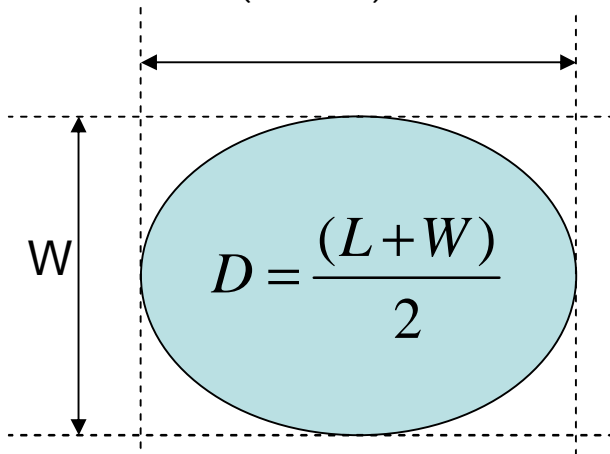

Note-4 : Line or Spiral Foreign Material  
( $W < L / 4$ )

