

CONTENTS

1. SUMMARY	1
1.1 General Description.....	1
1.2 Features.....	1
2. GENERAL SPECIFICATIONS	1
3. INPUT / OUTPUT TERMINALS	2
3.1 CN Pin assignment (LCD Interface).....	2
4. ABSOLUTE MAXIMUM RATINGS	3
5. ELECTRICAL CHARACTERISTICS	4
5.1 DC Characteristics for Panel Driving.....	4
5.2 DC Characteristics for Backlight Driving.....	4
5.3 Recommended Power ON/OFF Sequence.....	5
5.4 LCD Module Block Diagram.....	6
6. TIMING CHARACTERISTICS	7
6.1 LVDS AC characteristics	7
6.2 LVDS DC characteristics.....	8
6.3 LVDS signal timing characteristics.....	9
6.4 Input Clock and Data timing Diagram.....	10
6.5 LVDS data input forma.....	10
7. OPTICAL CHARACTERISTICS	12
8. RELIABILITY TEST	15
9. MECHANICAL DRAWING	16
10. PACKING INSTRUCTION	17
11. PRECAUTIONS FOR USE OF LCD MODULES	20
11.1 Handling Precautions.....	20
11.2 Storage precautions	20
11.3 Transportation Precautions	20
11.4 Screen saver Precautions.....	20
11.5 Safety Precautions	20

1. Summary

1.1 General Description

This is a 12.1 inch a-Si TFT-LCD module with Normal- Black technology. It is composed of a TFT-LCD panel, a driver circuit, PCB, LED backlight, unit.

1.2 Features

- Ultra-wide viewing angle
- Interface: LVDS
- Acquisition product for UL62368-1/CSA C22.2 No.62368-1-03
- Compliant with the European RoHS Directive (2011/65/EU) and Delegated Directive (2015/863/EU, Amending Annex II of 2011/65/EU)

2. General Specifications

	Feature	Spec	Unit
Display Spec	Size	12.1 inch	
	Resolution	1280(RGB) x 800	
	Pixel Pitch	0.204x0.204	mm
	TFT Active Area	261.1x163.2	mm
	Technology Type	a-Si	
	Pixel Configuration	R.G.B Vertical Stripe	
	Display Mode	SFT	
	Surface Treatment	Anti-Glare	
	Viewing Direction	All direction	
	Gray Scale Inversion Direction	NA	
Mechanical Characteristics	LCM (W x H x D)	278.0x184.0x9.9	mm
	Weight	445	g
Optical Characteristics	Luminance	450	cd/m ²
	Contrast Ratio	1000:1	
	NTSC	72	%
	Viewing Angle	88/88/88/88	degree
Electrical Characteristics	Interface	1port LVDS, 6/8bit selectable	
	Color Depth	16.7M/262k	color
	Power Consumption	LCD:660 Backlight:9444	mW

Table 2.1 General TFT Specifications

3. Input / Output Terminals

3.1 CN Pin assignment (LCD Interface)

Connector Information	
LCD Module connector	MSAKT2407P30HB(STM) or equivalent
Matching connector	JAE FI-X30CL

Table 3.1.1 Connector information

No	Symbol	I/O	Description	Comment
1	VLED	P	Backlight power supply +12V	
2	VLED	P	Backlight power supply +12V	
3	VLED	P	Backlight power supply +12V	
4	VLED	P	Backlight power supply +12V	
5	VLED_EN	I	Backlight on/off control (1: ON, 0:OFF)	
6	VLED_PWM	I	Backlight dimming control	
7	GND	P	Power ground	
8	GND	P	Power ground	
9	VDD	P	Power Supply +3.3V	
10	VDD	P	Power Supply +3.3V	
11	GND	P	Power ground	
12	GND	P	Power ground	
13	Rxin0-	I	-LVDS differential data input(R0~R5,G0)	
14	Rxin0+	I	+LVDS differential data input(R0~R5,G0)	
15	GND	P	Power ground	
16	Rxin1-	I	-LVDS differential data input(G1~G5,B0~B1)	
17	Rxin1+	I	+LVDS differential data input(G1~G5,B0~B1)	
18	GND	P	Power ground	
19	Rxin2-	I	-LVDS differential data input(B2~B5,HS,VS,DE)	
20	Rxin2+	I	+LVDS differential data input(B2~B5,HS,VS,DE)	
21	GND	P	Power ground	
22	RxCLK-	I	-LVDS differential data input	
23	RxCLK+	I	+LVDS differential data input	
24	GND	P	Power ground	
25	Rxin3-	I	-LVDS differential data input(R6~R7,G6~G7,B6~B7)	
26	Rxin3+	I	+LVDS differential data input(R6~R7,G6~G7,B6~B7)	
27	GND	P	Power ground	
28	SEL6/8	I	Low-->6 bit input mode High or NC-->8 bit input mode	
29	GND	P	Power ground	
30	GND	P	Power ground	

Table 3.1.2 Pin Assignment for LCD Interface

Note1: I/O definition: I---Input, O---Output, P---Power/Ground, N---No connection

Note2: All of the GND pins should be connected to the system ground.

Note3: Display direction (PCB at down side)

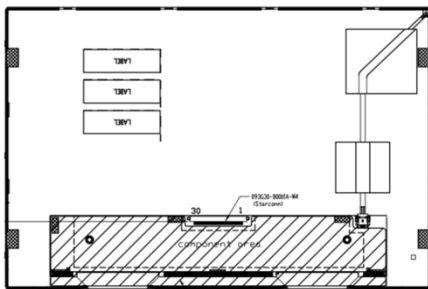

4. Absolute Maximum Ratings

Item	Symbol	MIN	MAX	Unit	Remark
Power Voltage	VDD	-0.5	4.0	V	Note1
LED power	VLED	-0.50	33V	V	
LED control	VLED_EN、 VLED_PWM	-0.50	5.5V	V	
Operating Temperature	Top	-20	70	°C	
Storage Temperature	Tst	-30	80	°C	
Relative Humidity Note2	RH	--	≤95	%	Ta≤40°C
		--	≤85	%	40°C < Ta≤50°C
		--	≤55	%	50°C < Ta≤60°C
		--	≤36	%	60°C < Ta≤70°C
		--	≤24	%	70°C < Ta≤80°C
Absolute Humidity	AH	--	≤70	g/m ³	Ta>70°C

Table 4.1 Absolute Maximum Ratings

Note1: Input voltage include all in put data.

Note2: Ta means the ambient temperature. It is necessary to limit the relative humidity to the specified temperature range. Condensation on the module is not allowed.

5. Electrical Characteristics

5.1 DC Characteristics for Panel Driving

Item	Symbol	MIN	TYP	MAX	Unit	Remark	
Supply Voltage	VDD	3.0	3.3	3.6	V	Include ripple	
Power supply ripple	Vp-p	-	-	100	mV		
Power supply current	IDD	-	200	-	mA		
Power consumption	P	-	660	-	mW	Note1	
Differential input voltage	Vid	200	-	600	mV		
Differential input common voltage	V _{CM}	1	1.2	1.4	V		
Output Signal Voltage	Low level	V _T L	-100	-	-	mV	
	High level	V _T H	-	-	100	mV	
Inrush current	I _{rush}	-	-	1.5	A	Note2	

Table 5.1.1 Operating Voltages

Note1: : To test the current dissipation, using the “white pattern” shown .

VDD rising time is 470μs

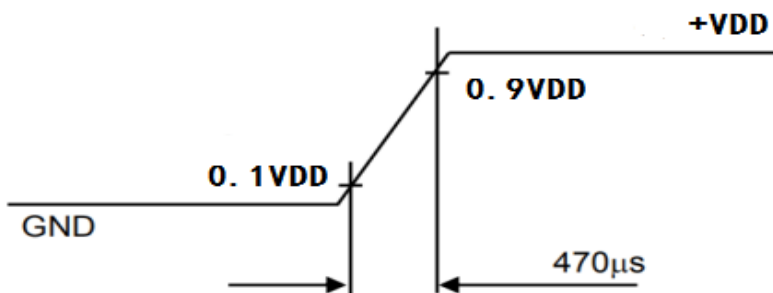

Note2: Inrush current definition

5.2 DC Characteristics for Backlight Driving

Item	Symbol	MIN	TYP	MAX	Unit	Remark	
Backlight power supply voltage	VLED	11	12	13	V	24 LEDs (3 LED Parallel, 8LED Serial)	
Backlight power supply current	I_LED	-	787	-	mA		
Backlight power consumption	P_LED	-	9444	-	mW		
LED life time	--						
Input voltage for VLED_PWM signal	High level	-	1.2	-	5.0	V	
	Low level	-	0	-	0.35	V	
Input voltage for VLED_EN	High level	-	1.5	-	5.0	V	
	Low level	-	0	-	0.8	V	
VLED_PWM frequency	F _{pwm}	200	-	10K	HZ		
VLED_PWM duty	D	3	-	100	%	Note1	
Operating Life Time	--		50000-	--	hrs	Note2	
Inrush current	I _R	-	-	1.5	A	Rising time:470us	

Table 5.2.1 LED Backlight Characteristics

Note1: I_F is defined for each channel.

Note2: Optical performance should be evaluated at $T_a=25^\circ\text{C}$ only.

Note3: If LED is driven by high current, high ambient temperature & humidity condition, The life time of LED will be reduced.

Note4: Operating life means brightness goes down to 50% of initial brightness. Typical operating life time is estimated data.

5.3 Recommended Power ON/OFF Sequence

Item	Symbol	Min	Typ	Max	Unit	Remark
VDD on to VDD stable	Tp1	0.5	-	-	ms	
VDD stable to signal on	Tp2	50	-	-	ms	
Signal on to VLED_EN on	Tp3	200	-	-	ms	
PWM on to VLED_EN on	Tp4	0	-	-	ms	
VLED to PWM on	Tp5	10	-	-	ms	
VLED on to VLED stable	Tp6	0.5	-	10	ms	
VDD off time	Tp7	-	-	10	ms	
VDD off to next VDD on	Tp8	500	-	-	ms	
Signal off before VDD off	Tp9	0	-	50	ms	
VLED_EN off before signal off	Tp10	200	-	-	ms	
VLED_EN off before PWM off	Tp11	0	-	-	ms	
PWM off before VLED off	Tp12	10	-	-	ms	

Table 5.4.1 Power on/off sequence

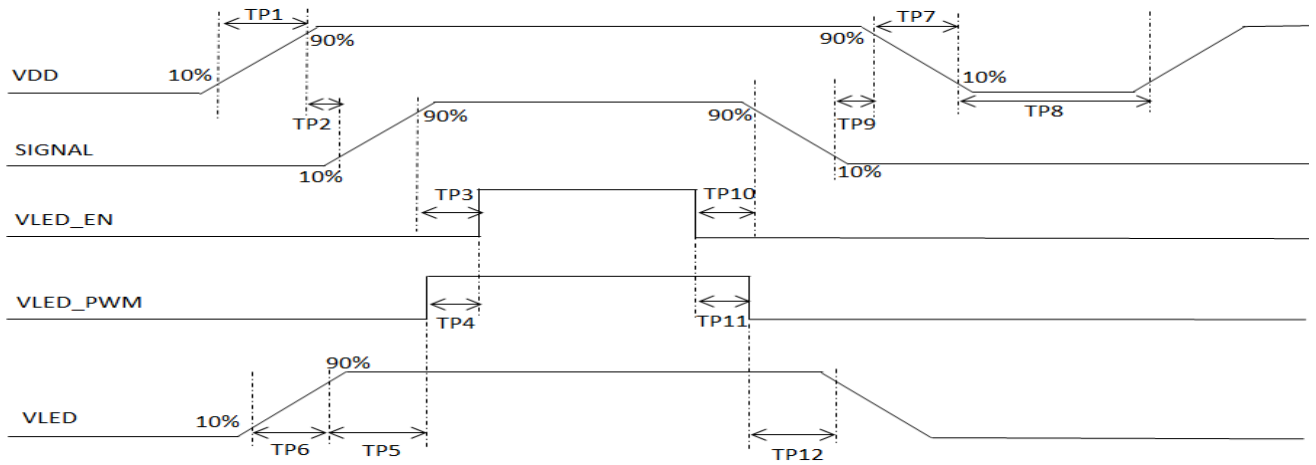
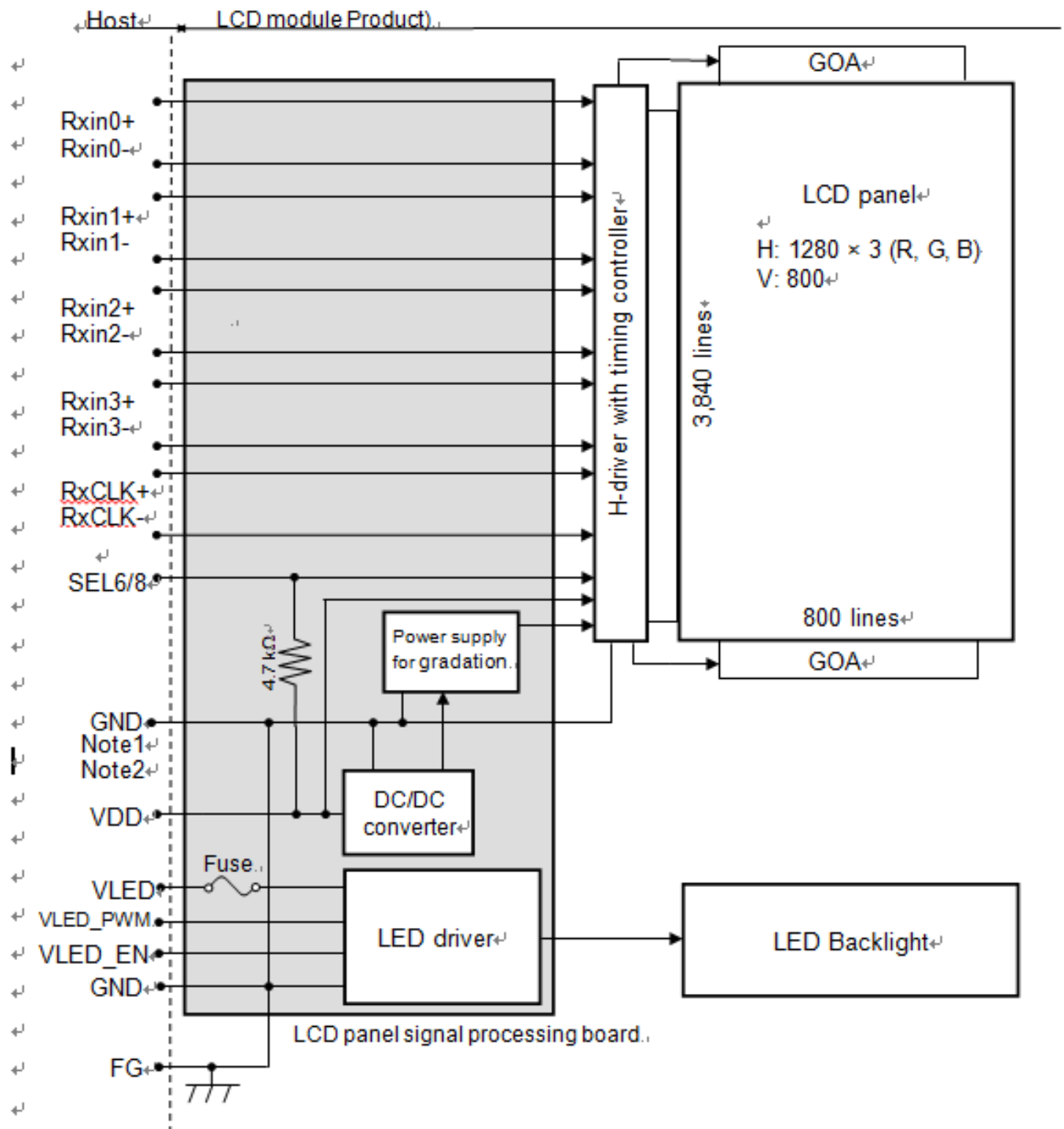

Figure 5.4.1 Power on/off sequence

Note: It is advised that backlight turned on later than display stabled.

Note2: The low level of these signals and analog powers are GND level.

5.4 LCD Module Block Diagram



Note1: Relations between GND (Signal ground and LED driver ground) and FG (Frame ground) in the LCD module are as follows:

GND - FG	Connected
----------	-----------

Note2: GND and FG must be connected to customer equipment's ground, and it is recommended that these grounds be connected together in customer equipment.

Figure 5.4.1 LCD Module Block Diagram

6. Timing Characteristics

6.1 LVDS AC characteristics

Parameter	Symbol	Spec.			Unit	Condition
		Min.	Typ.	Max.		
Clock frequency	$R_{x\text{FCLK}}$	30	-	TBD	MHz	Refer to input timing table for each display resolution
Input data skew margin	T_{RSKM}	500	-	-	ps	$ V_{\text{ID}} = 200\text{mV}$ $R_{\text{xVCM}} = 1.2\text{V}$ $R_{\text{xFCLK}} = 81\text{MHz}$
Clock high time	T_{LVCH}	-	$4/(7 * R_{\text{xFCLK}})$	-	ns	
Clock low time	T_{LVCL}	-	$3/(7 * R_{\text{xFCLK}})$	-	ns	
PLL wake-up time	T_{enPLL}	-	-	150	us	

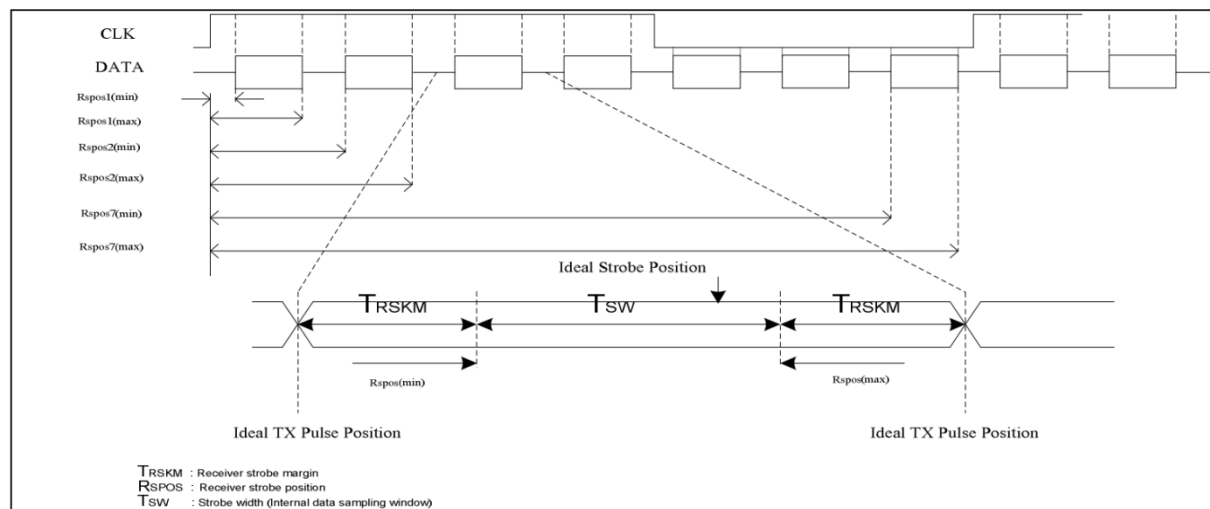
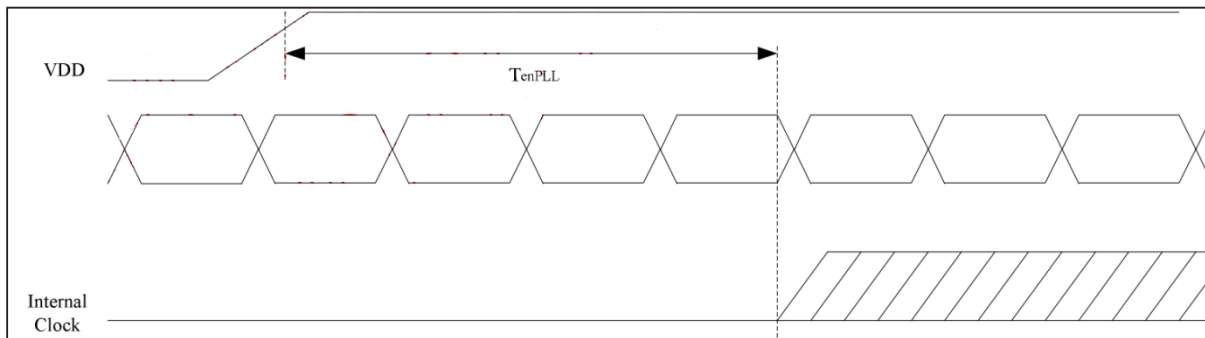
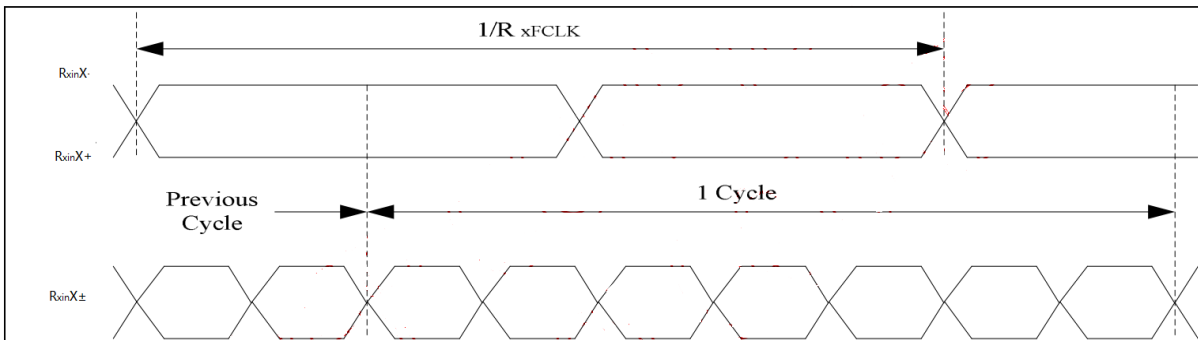

Figure 6.1.1 LVDS AC electrical characteristics

Note: The min value of clock frequency(30MHz) is based on IC SPEC, user should set on suggested value

6.2 LVDS DC characteristics

Parameter	Symbol	Min.	Typ.	Max.	Unit	Condition
Differential input high threshold voltage	R _{XVTH}	-	-	+0.1	V	R _{XVCM} =1.2V
Differential input low threshold voltage	R _{XVTL}	-0.1	-	-	V	
Input voltage range (singled-end)	R _{XVIN}	0.7	-	1.7	V	
Differential input common mode voltage	R _{XVCM}	1	1.2	1.4	V	V _{ID} =0.2
Differential input impedance	Z _{ID}	80	100	125	ohm	
Differential input voltage	V _{ID}	0.2	-	0.6	V	
Differential input leakage current	I _{LCLVDS}	-10	-	+10	uA	
LVDS Digital Operating Current	I _{VDD}	-	15	20	mA	F _{DCLK} =80MHz, V _{DD} =3.3V, Input pattern: 55h->Aah->55h->Aah
LVDS Digital Stand-by Current	I _{ST}	-	-	250	uA	Clock & all Functions are stopped

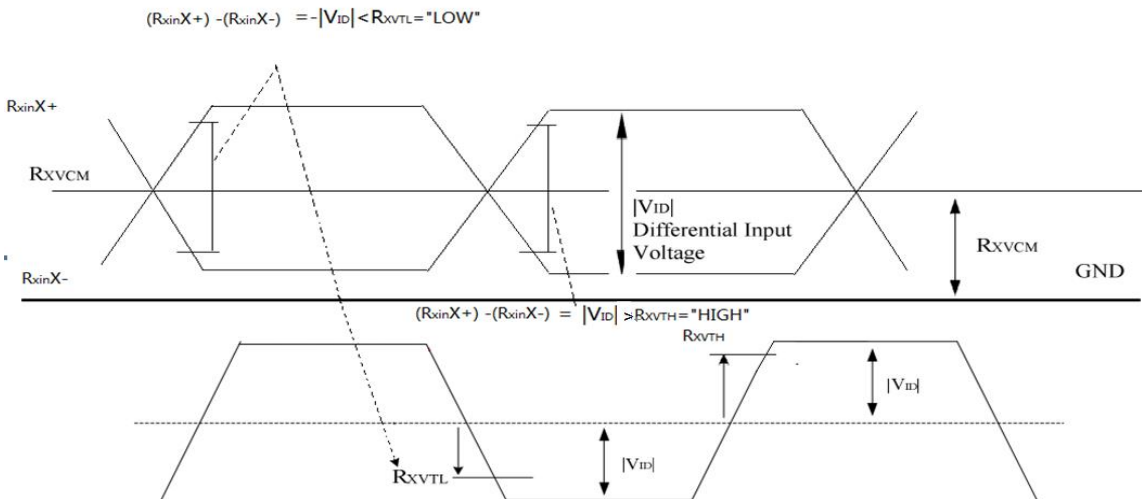

Figure 6.2.1 LVDS DC characteristics

Parameter	Symbol	Min.	Typ.	Max.	Unit
Clock frequency	F _{LVCYC}	68	73	78	MHz
Clock period	T _{LVCYC}			-	ps
1 data bit time	UI	-	1/7	-	T _{LVCYC}
Clock high time	T _{LVCH}	3.9	4	4.1	UI
Clock low time	T _{LVCL}	2.9	3	3.1	UI
Position 1	T _{POS1}	-0.2	0	0.2	UI
Position 0	T _{POS0}	0.8	1	1.2	UI
Position 6	T _{POS6}	1.8	2	2.2	UI
Position 5	T _{POS5}	2.8	3	3.2	UI
Position 4	T _{POS4}	3.8	4	4.2	UI
Position 3	T _{POS3}	4.8	5	5.2	UI
Position 2	T _{POS2}	5.8	6	6.2	UI
Input eye width	T _{EYEW}	0.6	-	-	UI
Input eye border	T _{EX}	-	-	0.2	UI
LVDS wake up time	T _{ENLVDS}	-	-	150	us

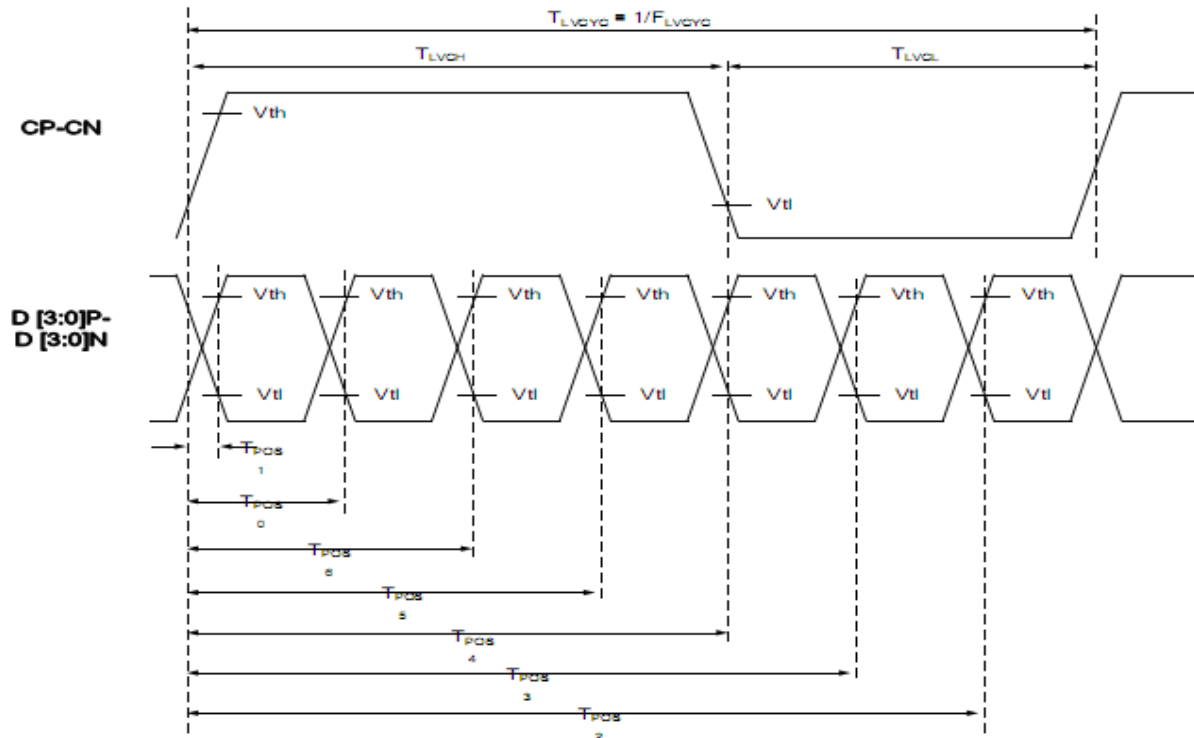

Figure 6.2.1 LVDS signal characteristics

6.3 LVDS signal timing characteristics

VCC=3.3V, GND=0V, Ta=25°C

Parameter	Symbol	Value			Unit	Note
		min	typ	max		
CLK frequency	t _{clk}	68	73	78	Mhz	
Horizontal blanking time	t _{HBT}	102	162	222	t _{clk}	t _{HBP} + t _{HFP} + t _{HPW}
Horizontal back porch	t _{HBP}	88			t _{clk}	
Horizontal display area	t _{HD}	1280			t _{clk}	
Horizontal front porch	t _{HFP}	-	72	-	t _{clk}	
Horizontal period	t _H	1382	1442	-	t _{clk}	
Horizontal pulse width	t _{HPW}	-	2	-	t _{clk}	
Vertical blanking time	t _{vBT}	26	40	74	t _H	t _{vBP} + t _{vFP} + t _{vPW}
Vertical back porch	t _{vBP}	23			t _H	
Vertical display area	t _{vD}	800			t _H	
Vertical front porch	t _{vFP}	-	15	-	t _H	
Vertical period	t _v	826	840	874	t _H	
Vertical pulse width	t _{vPW}	2			t _H	

Table 6.2.1 Timing Parameters

Note: Blanking setting must be even numbers.

6.4 Input Clock and Data timing Diagram

Vertical timing

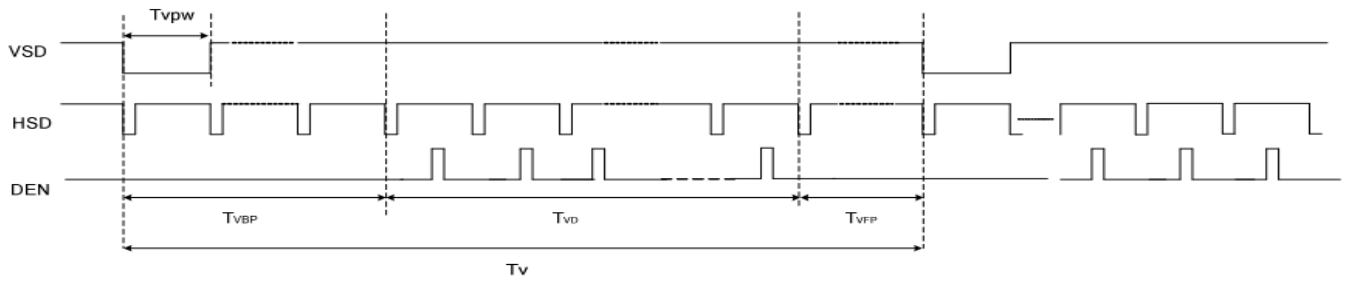

Horizontal timing

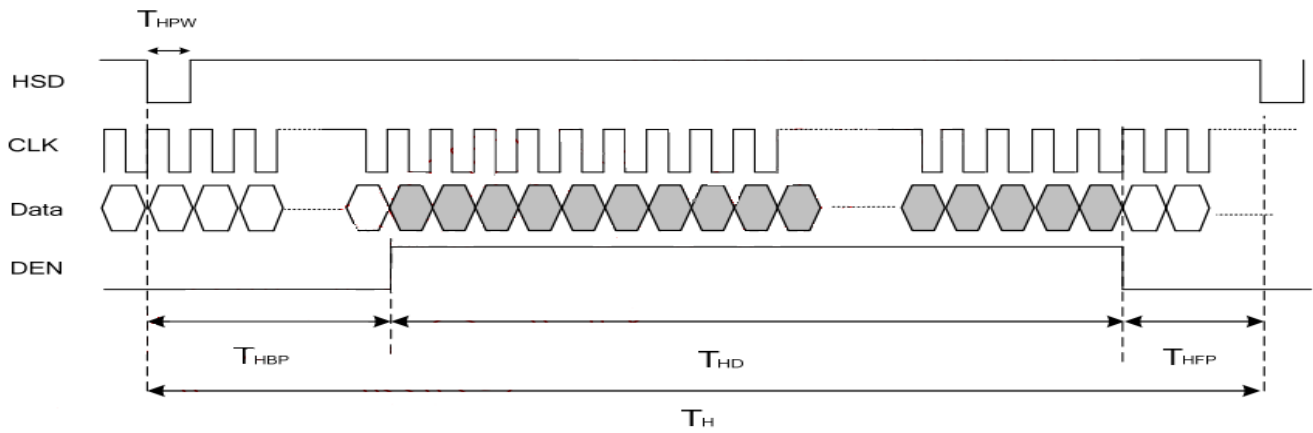
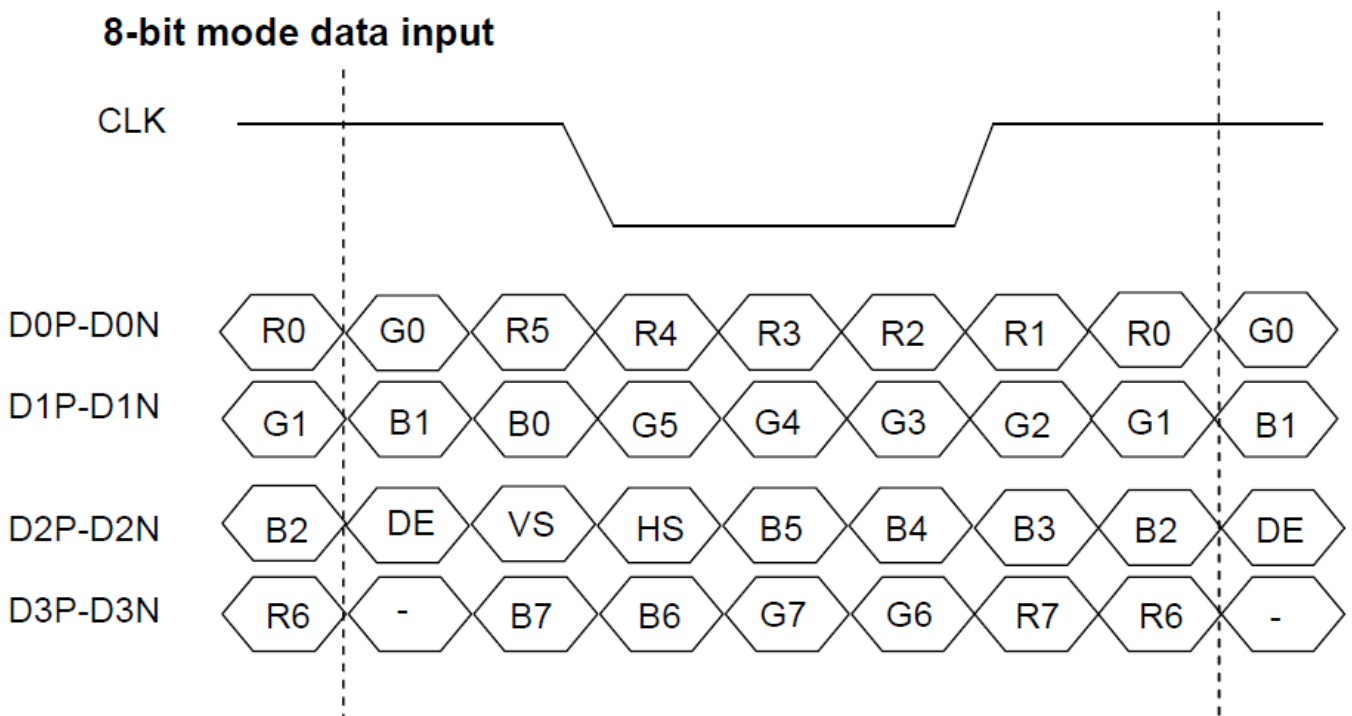

Figure 6.3.1 Input signal data timing

6.5 LVDS data input forma

8-bit mode data input



6-bit mode data input

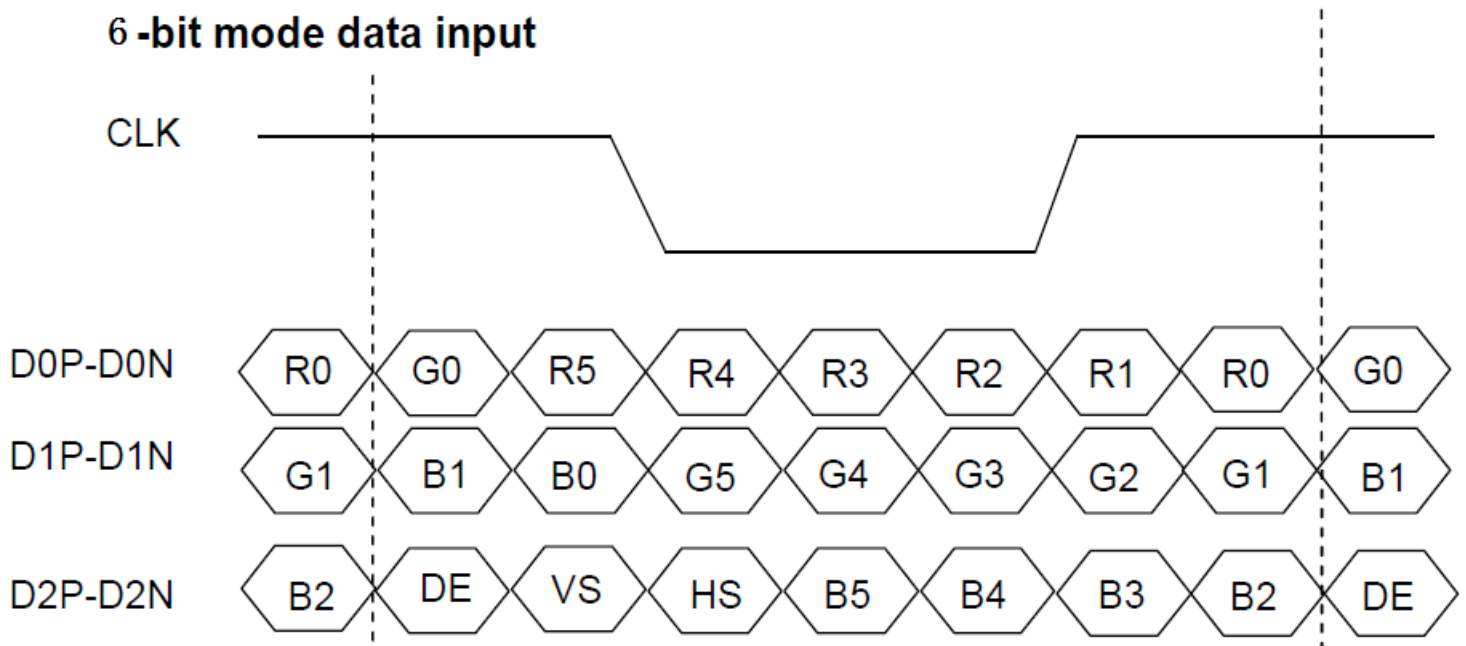

Figure 6.4.1 LVDS data input format (VESA standard)

Note: This LCD module supports HV mode only, so HSYNC&VSYNC signal is necessary

7. Optical Characteristics

Item	Symbol	Condition	Min	Typ	Max	Unit	Remark
View Angles	θT	$CR \geq 10$	75	88	-	degree	Note2,3
	θB		75	88	-		
	θL		75	88	-		
	θR		75	88	-		
Contrast Ratio	CR	$\theta=0^\circ$	800	1000	-		Note 3
Response Time	T_{ON}	25°C	-	25	40	ms	Note 4
	T_{OFF}						
Chromaticity	White	Backlight is on	x	0.259	0.309	0.359	.Note 1,5
			y	0.290	0.340	0.390	
	Red		x	0.591	0.641	0.691	
			y	0.389	0.339	0.389	
	Green		x	0.257	0.307	0.357	
			y	0.581	0.631	0.681	
	Blue		x	0.101	0.151	0.201	
			y	0.043	0.093	0.143	
Uniformity	U		70	75		%	Note 6
NTSC	-		67	72		%	Note 5
Luminance	L		360	450		cd/m ²	Note 7

Table 7.1 Optical Parameters

Test Conditions:

1. The ambient temperature is 25°C.
2. The test systems refer to Note1 and Note2.

Note1: Definition of optical measurement system.

The optical characteristics should be measured in dark room. The optical characteristics are measured at the center point of the LCD screen.

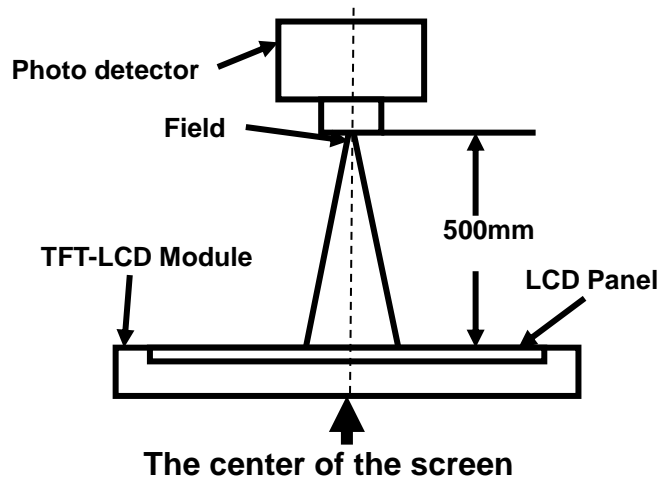

Fig1. Measurement Set Up

Note2: Definition of viewing angle range and measurement system. Viewing angle is measured at the center point of the LCD .

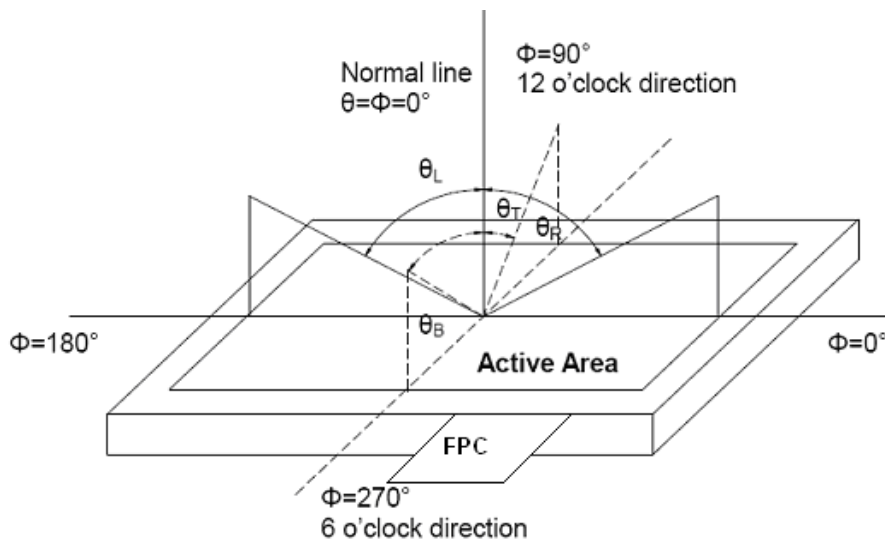

Fig2. Measurement viewing angle

Note3: Definition of contrast ratio

$$\text{Contrast ratio (CR)} = \frac{\text{Luminance measured when LCD is on the "White" state}}{\text{Luminance measured when LCD is on the "Black" state}}$$

Note4: Definition of Response time

For SFT LCM, the response time is defined as the LCD optical switching time interval between “White” state and “Black” state. Rise time (T_r) is the time between photo detector output intensity changed from 10% to 90%. And fall time (T_f) is the time between photo detector output intensity changed from 90% to 10%.

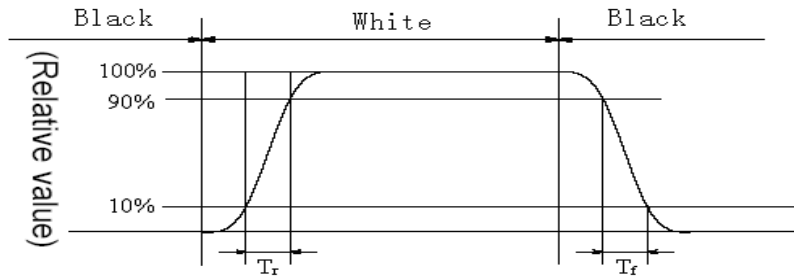

Fig3. Response Time Testing(SFT)

Note5: Definition of color chromaticity (CIE1931)

Color coordinates measured at center point of LCD.

Note6: Definition of Luminance Uniformity

Active area is divided into 9 measuring areas (Refer Fig.5). Every measuring point is placed at the center of each measuring area.

Luminance Uniformity (U) = L_{min} / L_{max}

L_{max} : The measured Maximum luminance of all measurement position.

L_{min} : The measured Minimum luminance of all measurement position.

L-----Active area length; W----- Active area width

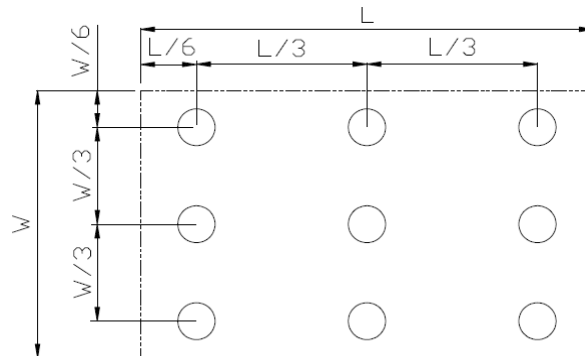

Fig5. Luminance Uniformity Measurement Locations(9 points)

Note7: Definition of Luminance:

Measure the luminance of white state at center point.

8. Reliability Test

No	Test Item	Condition	Remarks
1	High Temperature Operation	+70℃ , 240H	IEC60068-2-2:2007 GB2423.2-2008
2	Low Temperature Operation	-20℃ , 240H	IEC60068-2-1:2007 GB2423.1-2008
3	High Temperature Storage	+80℃ , 240H	IEC60068-2-2:2007 GB2423.2-2008
4	Low Temperature Storage	-30℃ , 240H	IEC60068-2-1:2007 GB2423.1-2008
5	Storage at High Temperature and Humidity(Operation)	+60℃ , 90%RH , 240H	IEC60068-2-78 :2012 GB/T2423.3—2006
6	Thermal Shock (non-operation)	-30℃ , 30min~80℃ , 30min , change time : 5min , 100cycle	Start with cold temperature, End with high temperature, IEC60068-2-14:2009,GB2423.22-2012
7	ESD	C=150pF , R=330Ω , 5point/panel Air : ±15kv , 5times ; Contact : ±8kv , 5times ; (Environment : 15℃~35℃ , 30%~60% , 86Kpa~106Kpa)	IEC61000-4-2:2008 GB/T17626.2-2018
8	Package Vibration	5-20-200HZ , PSD : 0.01-0.01-0.001 Total:0.781g2/HZ,x/y/z 30min)	GB/T 4857.23-2012
9	Package Drop Test	Height: X cm,1 corner, 3edges, 6 surfaces Note : X > 10Kg:60cm ; ≤10Kg:80cm	GB/T 4857.5-1992
10	Vibration (non-operation)	5~100HZ,19.60m/s ² ,1min/cycle 120times Per X\Y\Z	GB/T2423.10—2019
11	Shock (non-operation)	60G 6ms, ±X,±Y,±Z 3 times for each direction	GB/T2423.5—2019

Table 8.1 RA test condition

Note1: Temperature is the ambient temperature of sample

Note2: Before cosmetic and function test, the product must have enough recovery time, at least 24 hours at room temperature.

Note3: In the standard condition, there shall be no practical problem that may affect the display function. After the reliability test, the product's function only be guaranteed, but not for all of the cosmetic specification.

9. Mechanical Drawing

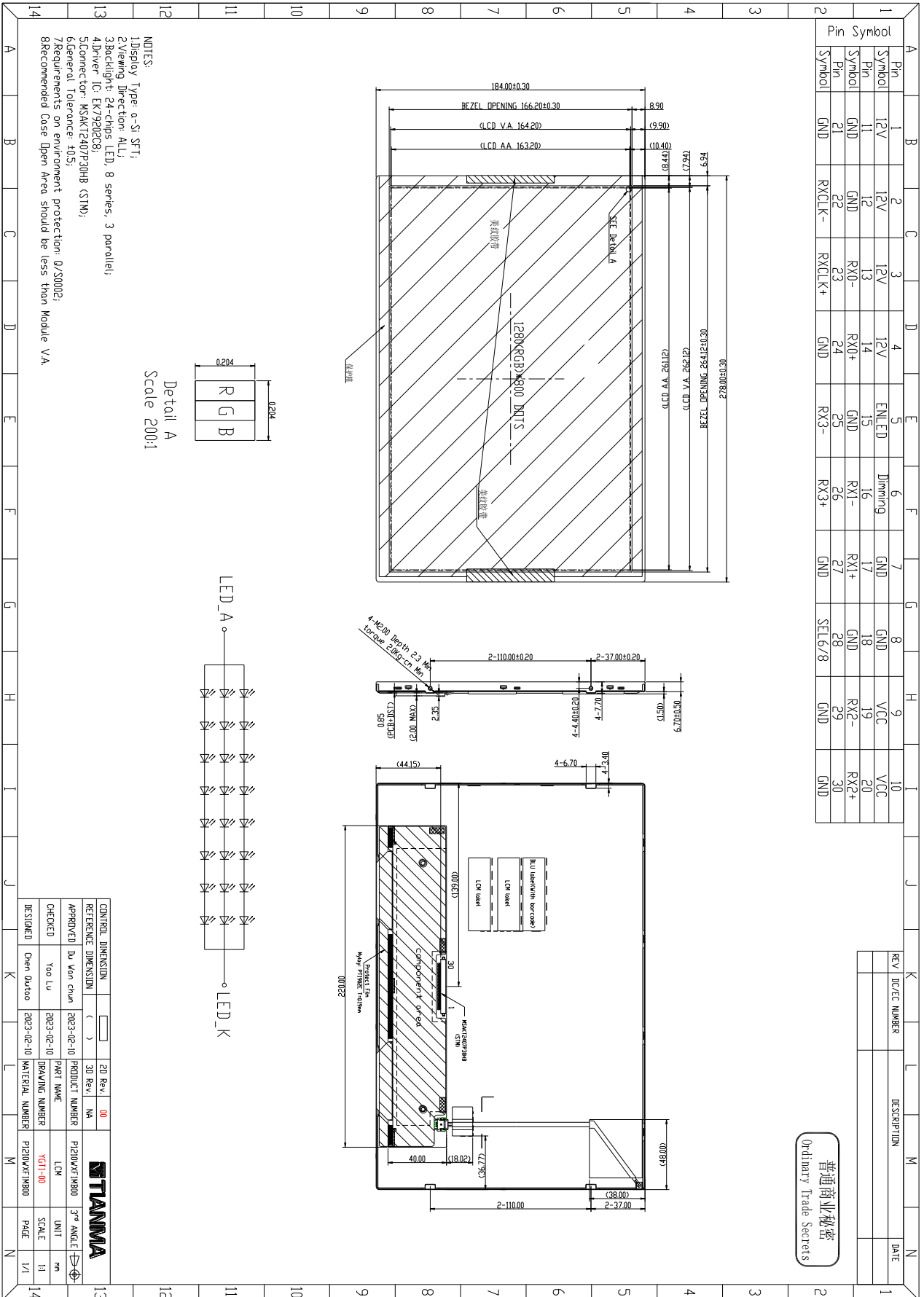

10. Packing Instruction

No	Item	Model (Materiel)	Dimensions(mm)	Unit Weight(Kg)	Quantity	Remark
1	LCM module	P1210WXF1MB00	278.0×184.0×9.90	0.445	15	
2	Carton	CORRUGATED PAPER	530×430×274	1.2	1	
3	Dust-proof Bag	PE	700×530×0.08	0.06	1	
4	Label	Label	100×52	0.000345	1	
5	EPE	EPE	395.0×249.0×5.0	0.0115	1	
6	Corrugated Bar	Corrugated paper	379.0×300.0	0.1	1	
7	Partition_1	CORRUGATED PAPER	513.0×295.0×240	1.77	1	
8	Partition_2	CORRUGATED PAPER	513.0×413.0×7	0.142	1	
9	Anti-static Bag	PE	300.0×250	0.0106	15	
10	Total weight	10.118kg±10%				

1. Single-piece module packaging, according to the figure below, wrap a single-piece module in a bubble bag.

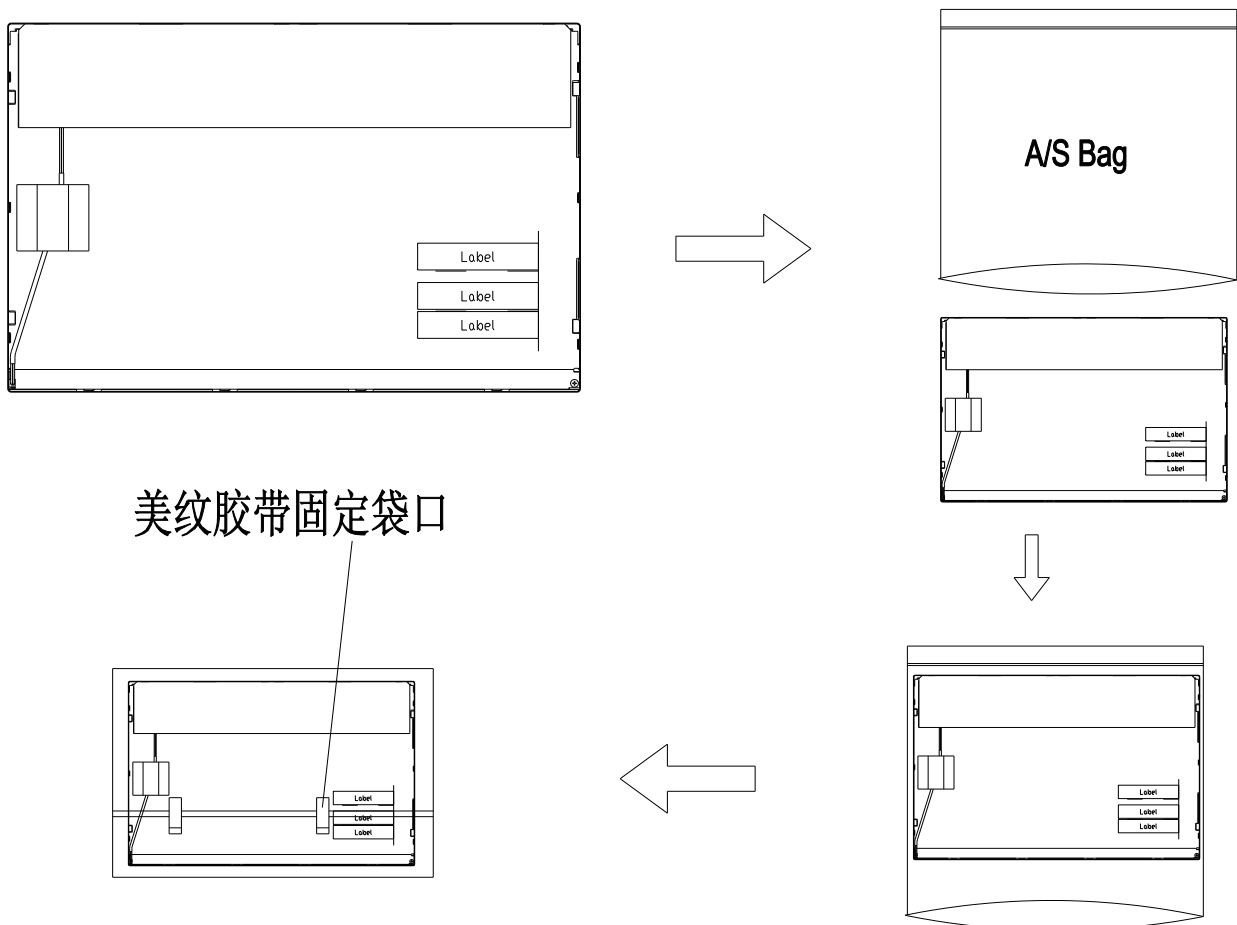

2. Dummy Packing assembly

A. Put the EPE into the crimp_1 as shown below:

Open the side bezel of crimp_1

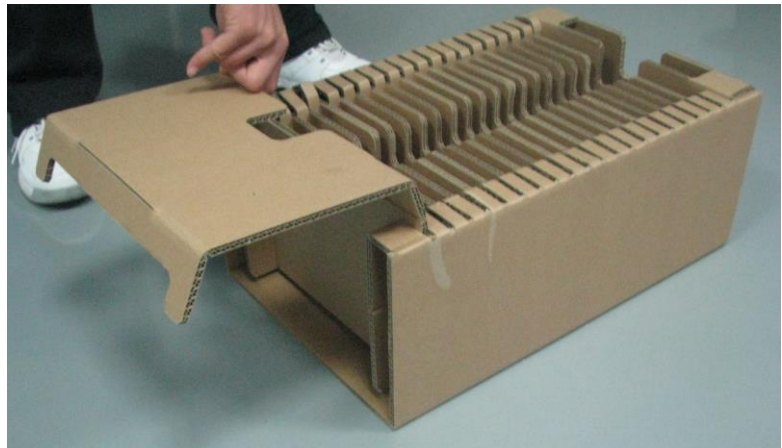
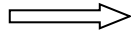

Place the EPE at the bottom of the crimp_1

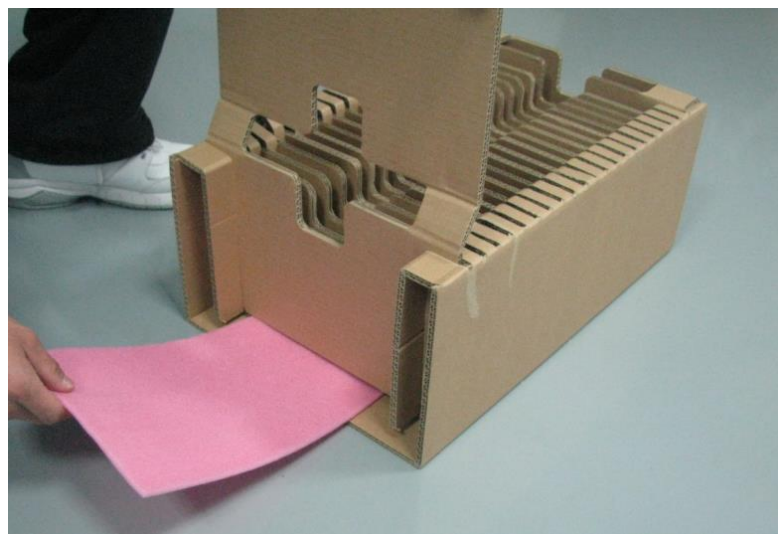
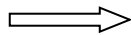

When finished, it is shown in the picture on the right

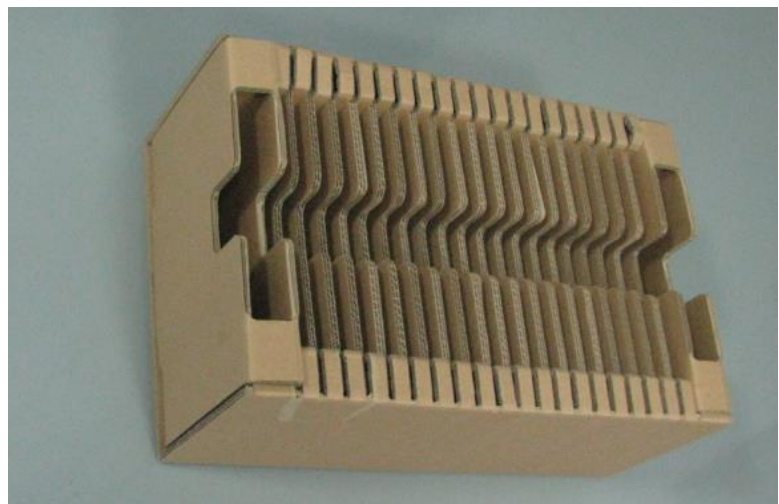
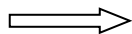

Note:

Verify that the EPE filler is placed on the bottom of the crimp_1 and not between the dust bag and crimp_1.

B. Put the crimping card_1 into the dust bag, and then put it together in the carton. The module light bar side is facing up, the PCB board side is facing down, and the module is put into the carton in turn (the outermost module LCD side is facing inward), as shown in the following figure:

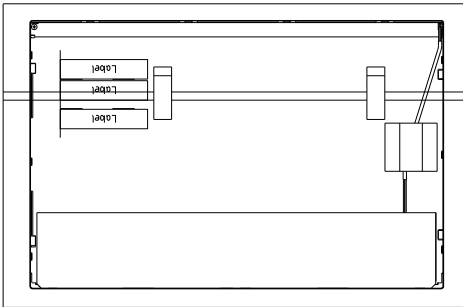

Note:

1. Please refer to BOM for the specifications of the outer carton label.
2. The content of the outer box label printing content, when the customer has the requirements, follow the customer's requirements, if there is no requirement, it will be according to the factory specifications.

C. Place the wave grid into the crimping card_1, cover the crimping card_2, and seal the dust bag:



D. Seal the carton:



11. Precautions for Use of LCD Modules

11.1 Handling Precautions

- (1) The display panel is made of glass. Do not subject it to mechanical shock by dropping it, etc.
- (2) If the display panel is damaged and the liquid crystal fluid inside it leaks out be sure not to get any in your mouth. If the fluid comes into contact with your skin or clothes promptly wash it off using soap and water.
- (3) Do not apply excessive force to the display surface or the bezel since this may cause the color tone to vary.
- (4) The polarizer covering the display surface of the LCD module is soft and easily scratched. Handle the polarizer carefully.
- (5) If the display surface is contaminated, breathe on the surface and gently wipe it with a soft dry cloth. If it is still not completely clear use a moist cloth with one of the following solvents:
 - Isopropyl alcohol
 - Ethyl alcoholSolvents other than those mentioned above may damage the polarizer. Specifically, do not use the following:
 - Water
 - Ketone
 - Aromatic solvents
- (6) Do not disassemble the LCD Module.
- (7) If powered off, do not apply the input signals.
- (8) To prevent destruction of the module by static electricity, be careful to maintain an optimum work environment.
- (9) Be sure to ground your body when handling the LCD Modules.
- (10) Tools used for assembly, must be properly grounded.
- (11) To reduce the amount of static electricity generated, do not conduct assembly or other work under very low humidity conditions.
- (12) The LCD Module is covered with a film to protect the display surface, remove film slowly under the ionizer.

11.2 Storage precautions

- (1) When storing the LCD modules avoid exposure to direct sunlight or to the light of fluorescent lamps.
- (2) The LCD modules should be stored within the rated storage temperature range. The recommend condition is: Temperature: 0 ~ 35 °C at normal humidity.
- (3) The LCD modules should be stored in a room without acid, alkali or other harmful gas.

11.3 Transportation Precautions

The LCD modules should not be dropped or subject to violent mechanical shock during transportation. Also they should avoid excessive pressure, water, high humidity and direct sunlight.

11.4 Screen saver Precautions

Not display the fixed pattern for a long time. Use a screen saver, if the fixed pattern is displayed on the screen

11.5 Safety Precautions

- (1) When you waste damaged or unnecessary LCDs, it is recommended to crush LCDs into pieces and wash them off with solvents such as acetone and ethanol, which should later be burned
- (2) Be sure to turn off the power supply when inserting or disconnecting the LED backlight cable.
- (3) LED driver should be designed to limit or stop its function when over current is detected on the LED.