



Product Selection Guide

www.sg-micro.de

SG Micro Corp

No. 87 North Xisanhuan Road, IFEC, Suite C-1301,
Haidian District, Beijing, China, 100089
Tel: 86-10-8882 5716/17
Fax: 86-10-8882 5736

SG Micro Corp



SGMICRO OVERVIEW

SG Micro Corp (SGMICRO) specializes in high performance, high quality analog IC design, marketing and sales, and offers innovative solutions for a broad range of applications in wireless communication, consumer, medical, automotive and industrial markets.

SGMICRO's technology expertise in analog IC and close partnership with customers are the driving forces for continuous improvements and innovations. Benefited from years of heavy investments in R&D and advanced technologies, SGMICRO has introduced more than 1500 analog IC products with excellent reliability and consistency, including precision signal conditioning products such as amplifiers, buffers, comparators, switches and interface products, as well as the energy efficient power management ICs.

Our innovative analog IC solutions with an extensive portfolio allow our customers to target such diverse and fast growing markets as smart devices, mobile electronics and green energy technologies, and have resulted in improved performance such as longer battery life, less peripheral components, smaller PCB space and lower cost.

Quality and reliability are on top of the priority list at SGMICRO at all times. SGMICRO strives to become one of the world's leading analog IC solution providers by offering our customers with best-quality products and services. It is therefore the policy of SGMICRO to continually improve our technologies and systems in an ongoing effort to meet and exceed our customers' expectations. Through the strictest QA system, SGMICRO assures each chip it produced of excellent quality and reliability.

We pursue the leading position in analog IC industry with advanced design, superior performance and excellent quality. We are committed to improve our lives and environment in every possible way through advancements in technology and technical innovations. SGMICRO strives to help our customers develop differentiated products and take the lead in their chosen markets.

CONTENTS

Operational Amplifier

Nano Power Operational Amplifiers.....	1
Micro Power Operational Amplifiers.....	1~2
High Speed Operational Amplifiers.....	3
High Precision Operational Amplifiers.....	3~5
Low Noise Operational Amplifiers.....	6~7
Special Function Operational Amplifiers.....	8
High Output Current Operational Amplifiers.....	9
Tiny Package Operational Amplifiers.....	10

Comparator

Nano Power Comparators.....	11
High Speed Comparators.....	11~12
High Voltage Comparators.....	12

Data Converter

Digital-to-Analog Converters.....	13
Oversampling Analog-to-Digital Converters.....	13

Voltage Reference

Shunt Voltage References.....	14
-------------------------------	----

Audio/Video Driver

High Performance Video Buffers.....	15
Headphone Drivers.....	16
High Performance Audio Line Drivers.....	16

Analog Switch

Analog Switches.....	17~18
Application-Specific Switches.....	19

Logic IC

Level Translators.....	20
Level Shifters and Drivers.....	20

Temperature Sensor

Temperature Sensors.....	21
--------------------------	----

Power Management IC

Supervisory Circuits.....	22
Over-Voltage Protection ICs.....	22~23
Li-Ion Battery Chargers and Protection ICs.....	23
DC/DC Converters.....	24~25
Charge Pump DC/DC Converters.....	25
High Reliability LDOs.....	25
High Accuracy, Low Noise, Low Power LDOs.....	26
Load Switches.....	26~27
Flash LED Driver.....	27
White LED Drivers.....	28
Isolated Power.....	28

Motor/Gate Driver

Motor Drivers.....	29
Gate Drivers.....	29



Nano Power Operational Amplifiers

The Nano Power Operational Amplifier family is designed to support rail-to-rail input and output operation and has as low as 350nA quiescent current. These specifications make these operational amplifiers extremely appropriate for low frequency low power applications, such as battery current monitoring and sensor conditioning.

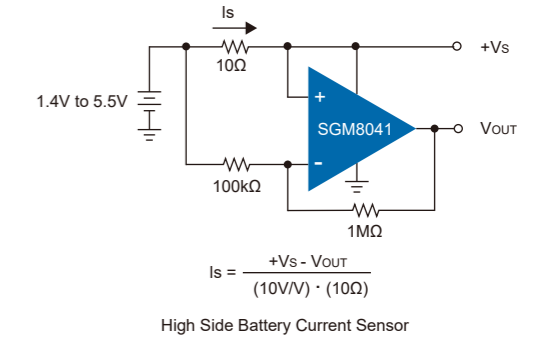

Amplifiers per Package	Part Number	1*		Shut-down	V _{CC} (V)	GBP Typ (kHz)	Slew Rate Typ (V/ms)	E _{NOISE} 0.1Hz ~ 10Hz (μV _{PP})	E _{NOISE} Typ @1kHz (nV/√Hz)	V _{OS} Max @25°C (mV)	TC of V _{OS} Typ (μV/°C)	I _B Typ (pA)	A _{VO} Typ (dB)	CMRR Typ (dB)	Rail-to-Rail Input	Rail-to-Rail Output	Package	Features
		I _Q /Amp Typ (μA)	I _Q /Amp Typ (μA)															
2	SGM8142	0.35		No	1.4 ~ 5.5	5	1.6	4	130	2.5	2	1	93	83	Yes	Yes	SOIC-8,MSOP-8	Ultra Low Quiescent Current, Rail-to-Rail Input and Output
1	SGM8141	0.38		No	1.4 ~ 5.5	5	1.5	4.9	125	2.5	2	1	90	80	Yes	Yes	SOT-23-5,SOIC-8,MSOP-8	Ultra Low Quiescent Current, Rail-to-Rail Input and Output
1	SGM8040-1	0.55		No	1.4 ~ 5.5	11	4	5	180	0.23	1	10	120	92	Yes	Yes	SOT-23-5,SC70-5,SOIC-8	Very Low Quiescent Current, Rail-to-Rail Input and Output
2	SGM8040-2	0.55		No	1.4 ~ 5.5	11	4	5	180	0.23	1	10	120	92	Yes	Yes	TDFN-2x2-8L,SOIC-8	Very Low Quiescent Current, Rail-to-Rail Input and Output
2	SGM8042	0.67		No	1.4 ~ 5.5	14.5	4.2	3.2	180	2.5	2.5	1	93	84	Yes	Yes	SOIC-8,MSOP-8	Very Low Quiescent Current, Rail-to-Rail Input and Output
4	SGM8044	0.67		No	1.4 ~ 5.5	15	3.4	3.2	190	2.5	2.5	1	93	83	Yes	Yes	SOIC-14,TSSOP-14,TQFN-3x3-16L	Very Low Quiescent Current, Rail-to-Rail Input and Output
2	SGM8046	0.67		No	1.4 ~ 5.5	100	14.5	3	190	2.5	2.5	1	92	82	Yes	Yes	SOIC-8,MSOP-8	Stable for Gain of 10, 100kHz, Very Low I _Q , RRIO
4	SGM8048	0.69		No	1.4 ~ 5.5	100	14.5	3.5	205	2.5	2.5	1	92	83	Yes	Yes	SOIC-14,TSSOP-14	Stable for Gain of 10, 100kHz, Very Low I _Q , RRIO
1	SGM8041	0.71		No	1.4 ~ 5.5	14.5	3.3	3.4	135	2.5	2.5	1	93	84	Yes	Yes	SOT-23-5,SOIC-8,MSOP-8	Very Low Quiescent Current, RRIO
1	SGM8045	0.71		No	1.4 ~ 5.5	100	16	3.2	160	2.5	2.5	1	93	84	Yes	Yes	SOT-23-5,SOIC-8,MSOP-8	Stable for Gain of 10, 100kHz, Very Low I _Q , RRIO
2	SGM8039-2	1.5		No	1.4 ~ 5.5	12	4	5	190	0.08†		5	120	96	Yes	Yes	MSOP-10	Very Low Quiescent Current, Integrated Special Switch, RRIO

Note: † Typical Values @ 25°C

Micro Power Operational Amplifiers

The Micro Power Operational Amplifier family is designed to support rail-to-rail input and output operation and has as low as 2.5μA quiescent current. These specifications make these operational amplifiers extremely appropriate for low frequency low power applications, such as battery current monitoring and sensor conditioning.

Amplifiers per Package	Part Number	1*		Shut-down	V _{CC} (V)	GBP Typ (MHz)	Slew Rate Typ (V/ms)	E _{NOISE} 0.1Hz ~ 10Hz (μV _{PP})	E _{NOISE} Typ @1kHz (nV/√Hz)	V _{OS} Max @25°C (mV)	TC of V _{OS} Typ (μV/°C)	I _B Typ (pA)	A _{VO} Typ (dB)	CMRR Typ (dB)	Rail-to-Rail Input	Rail-to-Rail Output	Package	Features
		I _Q /Amp Typ (μA)	I _Q /Amp Typ (μA)															
1	SGM8049-1	2.5		No	1.8 ~ 5.5	0.12	80	3.5	75	0.85	0.6	1	118	100	Yes	Yes	SOT-23-5,SC70-5,TDFN-2x2-6L	Pico Amp Input Current, Micro Power, Rail-to-Rail Input and Output
2	SGM8049-2	2.5		No	1.8 ~ 5.5	0.12	80	3.5	75	0.85	0.6	1	118	100	Yes	Yes	SOT-23-8,SOIC-8	Pico Amp Input Current, Micro Power, Rail-to-Rail Input and Output
4	SGM8049-4	2.5		No	1.8 ~ 5.5	0.12	80	3.5	75	0.85	0.6	1	118	100	Yes	Yes	TSSOP-14	Pico Amp Input Current, Micro Power, Rail-to-Rail Input and Output
1	SGM8240-1	2.8		No	2.7 ~ 24	0.1	50	3	100	1	3	5	120	110	Yes	Yes	SC70-5,SOT-23-5	High Voltage, Micro Power, Precision
2	SGM8240-2	2.8		No	2.7 ~ 24	0.1	50	3	100	1	3	5	120	110	Yes	Yes	TDFN-2x3-8L,SOIC-8,MSOP-8	High Voltage, Micro Power, Precision
4	SGM8240-4	2.8		No	2.7 ~ 24	0.1	50	3	100	1	3	5	120	110	Yes	Yes	SOIC-14	High Voltage, Micro Power, Precision
1	SGM8521	5.5		No	2.1 ~ 5.5	0.15	50		85	3.5	2	3	110	87	Yes	Yes	SOT-23-5,SOIC-8	Low Bias Current, Micro Power, Rail-to-Rail Input and Output
2	SGM8522	5.5		No	2.1 ~ 5.5	0.15	50		85	3.5	2	3	110	87	Yes	Yes	SOIC-8,MSOP-8	Low Bias Current, Micro Power, Rail-to-Rail Input and Output
4	SGM8524	5.5		No	2.1 ~ 5.5	0.15	50		85	3.5	2	3	110	87	Yes	Yes	SOIC-14,TSSOP-14	Low Bias Current, Micro Power, Rail-to-Rail Input and Output
1	SGM8954-1	9		No	1.8 ~ 5.5	0.11	40	1	65	0.035	0.055	60	125	108	Yes	Yes	SOT-23-5,SOIC-8,UTDFN-1.6x1.6-6L	Micro Power, CMOS, Zero-Drift, Rail-to-Rail Input and Output
2	SGM8954-2	9		No	1.8 ~ 5.5	0.11	40	1	65	0.035	0.055	60	125	108	Yes	Yes	SOIC-8,MSOP-8,TDFN-2x2-8L	Micro Power, CMOS, Zero-Drift, Rail-to-Rail Input and Output
1	SGM8953-1	17		No	1.8 ~ 5.5	0.2	50	1	50	0.05	0.06	80	118	106	Yes	Yes	SOT-23-5,SOIC-8,UTDFN-1.6x1.6-6L	Micro Power, CMOS, Zero-Drift, Rail-to-Rail Input and Output
2	SGM8953-2	17		No	1.8 ~ 5.5	0.2	50	1	50	0.05	0.06	80	118	106	Yes	Yes	SOIC-8,MSOP-8,TDFN-2x2-8L	Micro Power, CMOS, Zero-Drift, Rail-to-Rail Input and Output
1	SGM8531	18		No	2.1 ~ 5.5	0.5	200		33	3.5	1.7	0.5	104	75	Yes	Yes	SOT-23-5,SOIC-8	Low Bias Current, Micro Power, Rail-to-Rail Input and Output

Micro Power Operational Amplifiers

Amplifiers per Package	Part Number	1*		Shut-down	V _{CC} (V)	GBP Typ (MHz)	Slew Rate Typ (V/ms)	E _{NOISE} 0.1Hz ~ 10Hz (μV _{PP})	E _{NOISE} Typ @1kHz (nV/√Hz)	V _{OS} Max @25°C (mV)	TC of V _{OS} Typ (μV/°C)	I _B Typ (pA)	A _{VO} Typ (dB)	CMRR Typ (dB)	Rail-to-Rail Input	Rail-to-Rail Output	Package	Features
		I _Q /Amp Typ (μA)	Typ															
2	SGM8532	18	No	2.1 ~ 5.5	0.5	200	33	3.5	1.7	0.5	104	75	Yes	Yes	SOIC-8,MSOP-8	Low Bias Current, Micro Power, Rail-to-Rail Input and Output		
4	SGM8534	18	No	2.1 ~ 5.5	0.5	200	33	3.5	1.7	0.5	104	75	Yes	Yes	SOIC-14,TSSOP-14	Low Bias Current, Micro Power, Rail-to-Rail Input and Output		
1	SGM8541	46	No	2.1 ~ 5.5	1.1	520	27	3.5	2.7	0.5	105	80	Yes	Yes	SOT-23-5,SOIC-8,SC70-5	Pico Amp Input Current, Micro Power, Rail-to-Rail Input and Output		
2	SGM8542	46	No	2.1 ~ 5.5	1.1	520	27	3.5	2.7	0.5	105	80	Yes	Yes	SOIC-8,MSOP-8,TSSOP-8	Pico Amp Input Current, Micro Power, Rail-to-Rail Input and Output		
4	SGM8544	46	No	2.1 ~ 5.5	1.1	520	27	3.5	2.7	0.5	105	80	Yes	Yes	SOIC-14,TSSOP-14	Pico Amp Input Current, Micro Power, Rail-to-Rail Input and Output		
1	SGM8543	48	Yes	2.1 ~ 5.5	1.1	520	27	3.5	2.7	0.5	105	76	Yes	Yes	SOT-23-6,SOIC-8	Pico Amp Input Current, Micro Power, Rail-to-Rail Input and Output		
1	SGM8545	48	No	2.1 ~ 5.5	1.1	520	27	3.5	2.7	0.5	105	76	Yes	Yes	SOT-23-5	Pico Amp Input Current, Micro Power, Rail-to-Rail Input and Output		
1	SGM8210-1	50	No	3.3 ~ 24	1	300	3	25	1	1	5	120	115	Yes	Yes	SOT-23-5,SC70-5	High Voltage, Micro Power, Precision	
2	SGM8210-2	50	No	3.3 ~ 24	1	300	3	25	1	1	5	120	115	Yes	Yes	SOIC-8,MSOP-8,TDFN-2x3-8L	High Voltage, Micro Power, Precision	
4	SGM8210-4	50	No	3.3 ~ 24	1	300	3	25	1	1	5	120	115	Yes	Yes	SOIC-14	High Voltage, Micro Power, Precision	
1	SGM8535	80	No	1.8 ~ 5.5	1.5	800	30	3.4	1.5	3	103	85	No	Yes	SOT-23-5,SC70-5,SOIC-8,MSOP-8	1.5MHz, 1.8V, Unity-Gain Stable, Rail-to-Rail Output		
2	SGM8536	80	No	1.8 ~ 5.5	1.5	800	30	3.4	1.5	3	103	85	No	Yes	SOIC-8,MSOP-8	1.5MHz, 1.8V, Unity-Gain Stable, Rail-to-Rail Output		
1	SGM8537	80	Yes	1.8 ~ 5.5	1.5	800	30	3.4	1.5	3	103	85	No	Yes	SOT-23-6,SOIC-8,MSOP-8	1.5MHz, 1.8V, Unity-Gain Stable, Rail-to-Rail Output		
4	SGM8538	80	No	1.8 ~ 5.5	1.5	800	30	3.4	1.5	3	103	85	No	Yes	SOIC-14,TSSOP-14	1.5MHz, 1.8V, Unity-Gain Stable, Rail-to-Rail Output		
1	SGM8271	150	No	4.5 ~ 36	1.4	7000	43	3	3	20	100	95	No	Yes	SOT-23-5,SOIC-8,MSOP-8	1.4MHz, 7V/μs, Low Power, Rail-to-Rail Output		
2	SGM8272	150	No	4.5 ~ 36	1.4	7000	43	3	3	20	100	95	No	Yes	SOIC-8,MSOP-8	1.4MHz, 7V/μs, Low Power, Rail-to-Rail Output		
4	SGM8274	150	No	4.5 ~ 36	1.4	7000	43	3	3	20	100	95	No	Yes	SOIC-14,TSSOP-14	1.4MHz, 7V/μs, Low Power, Rail-to-Rail Output		
2	LM2904	220	No	3 ~ 32	1.1	350	8.7	36	5.8	10	111	118	No	Yes	SOIC-8,MSOP-8,TSSOP-8	High Voltage, Precision		
2	SGM8270-2	500	No	3.3 ~ 36	2.5	8000	3	15	2.8	0.8	10	120	85	Yes	Yes	SOIC-8,MSOP-8	High Voltage, Precision, Rail-to-Rail Input and Output	
4	SGM8270-4	500	No	3.3 ~ 36	2.2	8000	3.5	15	1.2	0.8	5	120	88	Yes	Yes	SOIC-14,TSSOP-14	High Voltage, Precision, Rail-to-Rail Input and Output	
1	SGM8273-1	600	No	3.3 ~ 36	4	6000	1.5	9	1	2	10	90	86	Yes	Yes	SOT-23-5,SOIC-8,MSOP-8	High Voltage, Precision, Rail-to-Rail Input and Output	
2	SGM8273-2	600	No	3.3 ~ 36	4	6000	1.5	9	1	2	10	90	86	Yes	Yes	SOIC-8	High Voltage, Precision, Rail-to-Rail Input and Output	
4	SGM8273-4	600	No	3.3 ~ 36	4	6000	1.5	9	1	2	10	90	86	Yes	Yes	SOIC-14	High Voltage, Precision, Rail-to-Rail Input and Output	
1	SGM8276-1	1400	No	3.3 ~ 36	10	8000	3	10	1.5	1	50	120	80	Yes	Yes	SOT-23-5	High Voltage, Low Noise, Precision, Rail-to-Rail Input and Output	
2	SGM8276-2	1400	No	3.3 ~ 36	10	8000	3	10	1.5	1	50	120	80	Yes	Yes	SOIC-8	High Voltage, Low Noise, Precision, Rail-to-Rail Input and Output	
4	SGM8276-4	1400	No	3.3 ~ 36	10	8000	3	10	1.5	1	50	120	80	Yes	Yes	SOIC-14	High Voltage, Low Noise, Precision, Rail-to-Rail Input and Output	

High Speed Operational Amplifiers

Amplifiers per Package	Part Number	1*	Bandwidth @-3dB (MHz)	Shut-down	V _{CC} (V)	Slew Rate Typ (V/μs)	E _{NOISE} Typ @1MHz (nV/√Hz)	V _{OS} Max @25°C (mV)	TC of V _{OS} Typ (μV/°C)	I _B Typ (pA)	I _O /Amp Typ (mA)	A _{VO} Typ (dB)	CMRR Typ (dB)	Rail-to-Rail Input	Rail-to-Rail Output	Package	Features
		GBP Typ (MHz)															
1	SGM8968-1	10		No	1.8 ~ 5.5	20	8 ^{††}	0.24	1	6	1.6	128	95	Yes	Yes	SOT-23-5,SOIC-8	10MHz High Precision Rail-to-Rail Input and Output Amp
2	SGM8968-2	10		No	1.8 ~ 5.5	20	8 ^{††}	0.24	1	6	1.6	128	95	Yes	Yes	MSOP-8,SOIC-8	10MHz High Precision Rail-to-Rail Input and Output Amp
4	SGM8968-4	10		No	1.8 ~ 5.5	20	8 ^{††}	0.24	1	6	1.6	128	95	Yes	Yes	SOIC-14,TSSOP-14	10MHz High Precision Rail-to-Rail Input and Output Amp
1	SGM8967-1	27		No	2.1 ~ 5.5	30	8 ^{††}	0.24	1	3	2.7	128	105	Yes	Yes	SOT-23-5,SOIC-8	27MHz High Precision Rail-to-Rail Input and Output Amp
2	SGM8967-2	27		No	2.1 ~ 5.5	30	8 ^{††}	0.24	1	3	2.7	128	105	Yes	Yes	MSOP-8,SOIC-8	27MHz High Precision Rail-to-Rail Input and Output Amp
1	SGM8967-3	27		Yes	2.1 ~ 5.5	30	8 ^{††}	0.05 ^{†††}	1	3	2.7	128	105	Yes	Yes	SOT-23-6	27MHz High Precision Rail-to-Rail Input and Output Amp
4	SGM8967-4	27		No	2.1 ~ 5.5	30	8 ^{††}	0.24	1	3	2.7	128	105	Yes	Yes	SOIC-14,TSSOP-14	27MHz High Precision Rail-to-Rail Input and Output Amp
1	SGM8965A-1	50		No	2.2 ~ 5.5	30	5.5 [†]	0.28	1.4	1	5	118	94	Yes	Yes	SOT-23-5,SOIC-8	50MHz High Precision Amp
2	SGM8965A-2	50		No	2.2 ~ 5.5	30	5.5 [†]	0.28	1.4	1	5	118	94	Yes	Yes	MSOP-8,SOIC-8	50MHz High Precision Amp
1	SGM8969-1	50		No	1.8 ~ 5.5	20	8 ^{††}	0.24	1	6	1.1	127	102	Yes	Yes	SOT-23-5	50MHz High Precision Rail-to-Rail Input and Output Amp
2	SGM8969-2	50		No	1.8 ~ 5.5	20	8 ^{††}	0.24	1	6	1.1	127	102	Yes	Yes	SOIC-8,TDFN-3x3-8L	50MHz High Precision Rail-to-Rail Input and Output Amp
1	SGM8301	57	110	No	4.5 ~ 12	140	65 ^{††}	18	12		7.5	105	75	No	Yes	SOT-23-5,SOIC-8,MSOP-8	110MHz High Voltage Rail-to-Rail Output Amp
2	SGM8302	57	110	No	4.5 ~ 12	140	65 ^{††}	18	12		7.5	105	75	No	Yes	SOIC-8,MSOP-8	110MHz High Voltage Rail-to-Rail Output Amp
4	SGM8304	57	110	No	4.5 ~ 12	140	65 ^{††}	18	12		7.5	105	75	No	Yes	SOIC-14,TSSOP-14	110MHz High Voltage Rail-to-Rail Output Amp
1	SGM80581	100	220	No	2.5 ~ 5.5	160	7	3	6.5	2	4.5	109	71	Yes	Yes	SOT-23-5,SOIC-8	220MHz Rail-to-Rail Input and Output Amp
2	SGM80582	100	220	No	2.5 ~ 5.5	160	7	3	6.5	2	4.5	109	71	Yes	Yes	SOIC-8,MSOP-8	220MHz Rail-to-Rail Input and Output Amp
4	SGM80584	100	220	No	2.5 ~ 5.5	160	7	3	6.5	2	4.5	109	71	Yes	Yes	SOIC-14	220MHz Rail-to-Rail Input and Output Amp

Notes: † Typical Values @ 100kHz
 †† Typical Values @ 10kHz
 ††† Typical Values @ 25°C

High Precision Operational Amplifiers

The High Precision Operational Amplifier family provides high precision, low noise, low drift, rail-to-rail input and output, and single/dual/quad channel operational amplifiers. The internal auto-zero circuit cancels the input offset voltage and drift over time and temperature, and eliminates the 1/f noise as well. The combination of these characteristics makes them good choices for temperature, position and pressure sensors, medical equipment, strain gauge amplifiers, or any other industrial applications requiring high precision, low noise and long term stability.

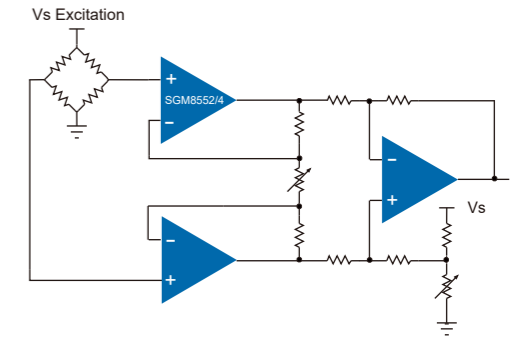

Amplifiers per Package	Part Number	1*	2*	I _B Typ (pA)	Shut-down	V _{CC} (V)	GBP Typ (MHz)	Slew Rate Typ (V/μs)	E _{NOISE} 0.1Hz ~ 10Hz (μV _{PP})	E _{NOISE} Typ @1kHz (nV/√Hz)	I _O /Amp Typ (μA)	A _{VO} Typ (dB)	CMRR Typ (dB)	Rail-to-Rail Input	Rail-to-Rail Output	Package	Features
		V _{OS} Max @25°C (mV)	TC of V _{OS} Typ (μV/°C)														
1	SGM8557-1	0.005	0.027	100	No	2.7 ~ 5.5	15	7	0.5	22	1150	144	120	No	Yes	SOT-23-5,SOIC-8,MSOP-8	High Precision, Low Noise, Zero-Drift
2	SGM8557-2	0.005	0.027	100	No	2.7 ~ 5.5	15	7	0.5	22	1150	144	120	No	Yes	SOIC-8	High Precision, Low Noise, Zero-Drift
1	SGM8557-3	0.005	0.027	100	Yes	2.7 ~ 5.5	15	7	0.5	22	1150	144	120	No	Yes	SOT-23-6,SOIC-8	High Precision, Low Noise, Zero-Drift, Single Amp with Shutdown
2	SGM8557-5	0.005	0.027	100	Yes	2.7 ~ 5.5	15	7	0.5	22	1150	144	120	No	Yes	MSOP-10	High Precision, Low Noise, Zero-Drift, Dual Amps with Shutdown
1	SGM8263-1	0.0085	0.01	60000	No	4 ~ 36	10	10	0.1	4.5	2500	145	135	No	Yes	SOT-23-5,SOIC-8	10MHz, Ultra Low Noise, Ultra Low Offset
2	SGM8263-2	0.0085	0.01	60000	No	4 ~ 36	10	10	0.1	4.5	2500	145	135	No	Yes	SOIC-8	10MHz, Ultra Low Noise, Ultra Low Offset

High Precision Operational Amplifiers

Amplifiers per Package	Part Number	1* V _{OS} Max @25°C (mV)	2* TC of V _{OS} Typ (μ V/°C)	I _B Typ (pA)	Shut-down	V _{CC} (V)	GBP Typ (MHz)	Slew Rate Typ (V/ μ s)	E _{NOISE} 0.1Hz ~ 10Hz (μ V _{PP})	E _{NOISE} Typ @1kHz (nV/ \sqrt Hz)	I _O /Amp Typ (μ A)	A _{VO} Typ (dB)	CMRR Typ (dB)	Rail-to-Rail -Rail Input	Rail-to-Rail -Rail Output	Package	Features
1	SGM8249-1	0.01	0.012	100	No	4.5 ~ 36	8	6	0.2	10	850	150	140	No	Yes	SOT-23-5,SOIC-8	High Voltage, High Precision, Low Noise, Rail-to-Rail Output
2	SGM8249-2	0.01	0.012	100	No	4.5 ~ 36	8	6	0.2	10	850	150	140	No	Yes	SOIC-8	High Voltage, High Precision, Low Noise, Rail-to-Rail Output
1	SGM8958-1	0.01	0.03	500	No	1.8 ~ 5.5	1.8	0.7	0.3	12	165	136	125	Yes	Yes	SOT-23-5,SC70-5,SOIC-8	High Precision, Low Noise, Zero-Drift
2	SGM8958-2	0.01	0.03	500	No	1.8 ~ 5.5	1.8	0.7	0.3	12	165	136	125	Yes	Yes	SOIC-8,TDFN-3x3-8L	High Precision, Low Noise, Zero-Drift
1	SGM8959-1	0.01	0.032	350	No	1.8 ~ 5.5	4	1		8	380	127	123	Yes	Yes	SOT-23-5,SC70-5,SOIC-8	High Precision, Low Noise, Zero-Drift
2	SGM8959-2	0.01	0.032	350	No	1.8 ~ 5.5	4	1		8	380	127	123	Yes	Yes	SOIC-8,TDFN-3x3-8L	High Precision, Low Noise, Zero-Drift
4	SGM8249-4	0.012	0.014	100	No	4.5 ~ 36	8	5	0.2	12	800	150	140	No	Yes	SOIC-14,TSSOP-14	High Voltage, High Precision, Low Noise, Rail-to-Rail Output
1	SGM8558-1	0.015	0.013	600	No	2.8 ~ 5.5	15	8	0.2	8	860	139	126	No	Yes	SOT-23-5,SOIC-8	High Precision, Low Noise, Zero-Drift
2	SGM8558-2	0.015	0.013	600	No	2.8 ~ 5.5	15	8	0.2	8	860	139	126	No	Yes	TDFN-3x3-8L,SOIC-8	High Precision, Low Noise, Zero-Drift
1	SGM8558-3	0.015	0.013	600	Yes	2.8 ~ 5.5	15	8	0.2	8	860	139	126	No	Yes	SOT-23-6	High Precision, Low Noise, Zero-Drift, Single Amp with Shutdown
4	SGM8558-4	0.015	0.013	600	No	2.8 ~ 5.5	15	8	0.2	8	860	139	126	No	Yes	SOIC-14	High Precision, Low Noise, Zero-Drift
1	SGM8251	0.018	0.02	100	No	4.5 ~ 36	2.8	1.3	0.4	20	450	150	135	No	Yes	SOT-23-5,SOIC-8,MSOP-8	High Voltage, High Precision, Low Noise
2	SGM8252A	0.018	0.02	100	No	4.5 ~ 36	2.8	1.3	0.4	20	450	150	135	No	Yes	SOIC-8,MSOP-8	High Voltage, High Precision, Low Noise
1	SGM8551	0.02	0.02	10	No	2.5 ~ 5.5	1.53	0.9	0.8	47.5	930	145	105	Yes	Yes	SOT-23-5,SOIC-8,MSOP-8	High Precision, Low Noise, Zero-Drift
2	SGM8552	0.02	0.02	10	No	2.5 ~ 5.5	1.53	0.9	0.8	47.5	465	145	105	Yes	Yes	SOIC-8,MSOP-8	High Precision, Low Noise, Zero-Drift
4	SGM8554	0.02	0.07	10	No	2.5 ~ 5.5	1.5	1	1.6	63	465	145	105	Yes	Yes	SOIC-14,TSSOP-14	High Precision, Low Noise, Zero-Drift
1	SGM8255A-1	0.025	0.018	100	No	4.5 ~ 36	8.5	5	0.2	12	850	150	135	No	Yes	SOT-23-5,SOIC-8,MSOP-8	High Voltage, High Precision, Low Noise
2	SGM8255A-2	0.025	0.018	100	No	4.5 ~ 36	8.5	5	0.2	12	850	150	135	No	Yes	SOIC-8,MSOP-8	High Voltage, High Precision, Low Noise
1	SGM8957-1	0.025	0.08	130	No	1.8 ~ 5.5	0.35	0.18	2		20	121	100	Yes	Yes	SOT-23-5,SC70-5,SOIC-8	High Precision, Low Noise, Micro Power, RRIO
2	SGM8957-2	0.025	0.08	130	No	1.8 ~ 5.5	0.35	0.18	2		20	121	100	Yes	Yes	SOIC-8,TDFN-3x3-8L,MSOP-8	High Precision, Low Noise, Micro Power, RRIO
1	SGM8954-1	0.035	0.055	60	No	1.8 ~ 5.5	0.11	0.04	1	65	9	125	108	Yes	Yes	SOT-23-5,SOIC-8,UTDFN-1.6x1.6-6L	Ultra Low Power, CMOS, Zero-Drift, RRIO
2	SGM8954-2	0.035	0.055	60	No	1.8 ~ 5.5	0.11	0.04	1	65	9	125	108	Yes	Yes	SOIC-8,MSOP-8,TDFN-2x2-8L	Ultra Low Power, CMOS, Zero-Drift, RRIO
1	SGM8275-1	0.035†	0.3	1000	No	3.6 ~ 36	0.6	3	0.3	8.5	750	130	140	No	Yes	SOT-23-5	High Voltage, Precision, Low Noise
2	SGM8275-2	0.035†	0.3	1000	No	3.6 ~ 36	0.6	3	0.3	8.5	750	130	140	No	Yes	SOIC-8	High Voltage, Precision, Low Noise
1	SGM8953-1	0.05	0.06	80	No	1.8 ~ 5.5	0.2	0.05	1	50	17	118	106	Yes	Yes	SOT-23-5,SOIC-8,UTDFN-1.6x1.6-6L	Ultra Low Power, CMOS, Zero-Drift, RRIO
2	SGM8953-2	0.05	0.06	80	No	1.8 ~ 5.5	0.2	0.05	1	50	17	118	106	Yes	Yes	SOIC-8,MSOP-8,TDFN-2x2-8L	Ultra Low Power, CMOS, Zero-Drift, RRIO
1	SGM8955	0.05	0.08	130	No	1.8 ~ 5.5	0.35	0.18	2		20	121	100	Yes	Yes	SOT-23-5,SC70-5,SOIC-8	High Precision, Low Noise, Micro Power, RRIO
2	SGM8956	0.05	0.08	130	No	1.8 ~ 5.5	0.35	0.18	2		20	121	100	Yes	Yes	SOIC-8,MSOP-8,TDFN-3x3-8L	High Precision, Low Noise, Micro Power, RRIO
1	SGM8250-1	0.05	0.11	80	No	3 ~ 24	0.35	0.09	0.85	40	50	145	130	Yes	Yes	SOT-23-5,SC70-5,SOIC-8	High Voltage, Micro Power, Zero-Drift
2	SGM8250-2	0.05	0.11	80	No	3 ~ 24	0.35	0.09	0.85	40	50	145	130	Yes	Yes	SOIC-8,TDFN-3x3-8L	High Voltage, Micro Power, Zero-Drift
1	SGM8555	0.09	0.05	30	No	2.5 ~ 5.5	3.5	3	0.6	21	950	133	98	Yes	Yes	SOT-23-5,SOIC-8,MSOP-8	3.5MHz, 3V/ μ s, High Precision, Low Noise, RRIO
2	SGM8556	0.09	0.05	30	No	2.5 ~ 5.5	3.5	3	0.6	21	950	133	98	Yes	Yes	SOIC-8,MSOP-8	3.5MHz, 3V/ μ s, High Precision, Low Noise, RRIO
1	SGM8581	0.1	0.1	15	No	2.5 ~ 5.5	1.45	0.75	0.85	47.5	445	145	90	Yes	Yes	SOT-23-5,SOIC-8,MSOP-8	High Precision, Low Noise, Zero-Drift
2	SGM8582	0.1	0.1	15	No	2.5 ~ 5.5	1.5	0.9	0.8	49	430	145	95	Yes	Yes	SOIC-8,MSOP-8	High Precision, Low Noise, Zero-Drift

Note: † Typical Values @ 25°C

High Precision Operational Amplifiers

Amplifiers per Package	Part Number	1*	2*		Shut-down	V _{CC} (V)	GBP Typ (MHz)	Slew Rate Typ (V/μs)	E _{NOISE} 0.1Hz ~ 10Hz (μV _{PP})	E _{NOISE} Typ @1kHz (nV/√Hz)	I _O /Amp Typ (μA)	A _{VO} Typ (dB)	CMRR Typ (dB)	Rail-to-Rail Input	Rail-to-Rail Output	Package	Features
		V _{OS} Max @25°C (mV)	TC of V _{OS} Typ (μV/°C)	I _B Typ (pA)													
4	SGM8584	0.1	0.15	60	No	2.5 ~ 5.5	1.5	0.9	1.4	78	430	135	92	Yes	Yes	SOIC-14,TSSOP-14	High Precision, Low Noise, Zero-Drift
1	SGMOP17C	0.12	0.02	100	No	4.5 ~ 36	2.8	1.3	0.4	20	450	150	135	No	Yes	SOT-23-5	High Voltage, High Precision, Low Noise
2	SGMOP17C-2	0.12	0.02	100	No	4.5 ~ 36	2.8	1.3	0.4	20	450	150	135	No	Yes	SOIC-8	High Voltage, High Precision, Low Noise
1	SGMOP07E	0.15	0.3	1000	No	3.6 ~ 36	0.6	3	0.3	8.5	750	130	140	No	Yes	SOIC-8	High Voltage, High Precision, Low Noise
1	SGM8040-1	0.23	1	10	No	1.4 ~ 5.5	0.011	0.004	5	180	0.55	120	92	Yes	Yes	SOT-23-5,SC70-5,SOIC-8	High Precision, Unity-Gain Stable, RRIO
2	SGM8040-2	0.23	1	10	No	1.4 ~ 5.5	0.011	0.004	5	180	0.55	120	92	Yes	Yes	SOIC-8,TDFN-2×2-8L	High Precision, Unity-Gain Stable, RRIO
1	SGM8967-1	0.24	1	3	No	2.1 ~ 5.5	27	30		18	2700	128	105	Yes	Yes	SOT-23-5,SOIC-8	27MHz High Precision Rail-to-Rail Input and Output Amp
2	SGM8967-2	0.24	1	3	No	2.1 ~ 5.5	27	30		18	2700	128	105	Yes	Yes	SOIC-8,MSOP-8	27MHz High Precision Rail-to-Rail Input and Output Amp
1	SGM8968-1	0.24	1	6	No	1.8 ~ 5.5	10	20		18	1600	128	95	Yes	Yes	SOT-23-5,SOIC-8	10MHz High Precision Rail-to-Rail Input and Output Amp
2	SGM8968-2	0.24	1	6	No	1.8 ~ 5.5	10	20		18	1600	128	95	Yes	Yes	SOIC-8,MSOP-8	10MHz High Precision Rail-to-Rail Input and Output Amp
1	SGM8295-1	0.25	0.4	1000	No	3.6 ~ 36	9	8	0.28	4.5	1500	130	140	No	Yes	SOIC-8,SOT-23-5	High Voltage, High Precision, Low Noise
2	SGM8295-2	0.25	0.4	1000	No	3.6 ~ 36	9	8	0.28	4.5	1500	130	140	No	Yes	SOIC-8,MSOP-8	High Voltage, High Precision, Low Noise
4	SGM8295-4	0.25	0.4	1000	No	3.6 ~ 36	9	8	0.28	4.5	1500	130	140	No	Yes	SOIC-14	High Voltage, High Precision, Low Noise
1	SGM8965-1	0.25	1.2	0.5	No	2.2 ~ 5.5	50	30	5	4.5 ^{††}	5300	115	100	Yes	Yes	SOT-23-5,SOIC-8	50MHz, High Precision Amp
2	SGM8965-2	0.25	1.2	0.5	No	2.2 ~ 5.5	50	30	5	4.5 ^{††}	5300	115	100	Yes	Yes	SOIC-8,MSOP-8	50MHz, High Precision Amp
2	SGM8261-2	0.35	1	40000	No	3.6 ~ 36	16	16	0.1	1.6	3800	140	135	No	Yes	TDFN-3×3-8BL,SOIC-8,MSOP-8	High Voltage, High Precision, Ultra Low Noise, HiFi Audio Amp
2	SGM8262-2	0.5	0.5	40000	No	4.5 ~ 36	50	33		3.5	9000	110	125	No	Yes	SOIC-8,TDFN-3×3-8BL	50MHz, Ultra Low Noise, HiFi High Output Current Audio Amp
1	SGM8925	0.6	2.5	1	No	1.6 ~ 5.5	0.11	0.04		105	6.4	93	85	No	Yes	SOT-23-5,SC70-5,SOIC-8,MSOP-8	High Precision, Very Low Quiescent Current, Low-side Current Sense
1	SGM8927	0.6	2.5	1	Yes	1.6 ~ 5.5	0.11	0.04		105	6.4	93	85	No	Yes	SOT-23-6,SOIC-8,MSOP-8	High Precision, Very Low Quiescent Current, Low-side Current Sense
1	SGM8951	0.8			No	1.8 ~ 5.5	0.11	0.045	3.5	115	26	92	92	Yes	Yes	SOT-23-5,SOIC-8	High Precision, Low Noise, Micro Power, RRIO
2	SGM8952	0.8			No	1.8 ~ 5.5	0.11	0.045	3.5	115	17	92	92	Yes	Yes	SOIC-8,MSOP-8	High Precision, Low Noise, Micro Power, RRIO
1	SGM8931	0.9	1.5	3	No	1.8 ~ 5.5	1.5	0.8		30	80	100	86	No	Yes	SOT-23-5,SC70-5,SOIC-8,MSOP-8	High Precision, Low Power, Low Noise, Rail-to-Rail Output
2	SGM8932	0.9	1.5	3	No	1.8 ~ 5.5	1.5	0.8		30	80	100	86	No	Yes	SOIC-8,MSOP-8	High Precision, Low Power, Low Noise, Rail-to-Rail Output
1	SGM8933	0.9	1.5	3	Yes	1.8 ~ 5.5	1.5	0.8		30	80	100	86	No	Yes	SOT-23-6,SOIC-8,MSOP-8	High Precision, Low Power, Low Noise, Rail-to-Rail Output
4	SGM8934	0.9	1.5	3	No	1.8 ~ 5.5	1.5	0.8		30	80	100	86	No	Yes	SOIC-14,TSSOP-14	High Precision, Low Power, Low Noise, Rail-to-Rail Output
2	SGM8922A	0.9	1.6		No	3.0 ~ 5.5	12.7	6.8		6	3000	104	108	No	Yes	SOIC-8,MSOP-8,TSSOP-8	High Precision, 300mA Output Short Circuit Current, Rail-to-Rail Output
2	SGM8926	0.9	2.5	1	No	1.6 ~ 5.5	0.11	0.04		105	6.4	93	85	No	Yes	SOIC-8,MSOP-8	High Precision, Very Low Quiescent Current, Low-side Current Sense
2	SGM8924A	1	1.5		No	3.0 ~ 5.5	8.9	5.1		6	5500	105	102	No	Yes	MSOP-10	High Precision, 300mA Output Short Circuit Current, Rail-to-Rail Output
1	SGM8273-1	1	2	10	No	3.3 ~ 36	4	6	1.5	9	600	90	86	Yes	Yes	SOT-23-5,SOIC-8,MSOP-8	Low Noise, High Precision, High Voltage RRIO
2	SGM8273-2	1	2	10	No	3.3 ~ 36	4	6	1.5	9	600	90	86	Yes	Yes	SOIC-8	Low Noise, High Precision, High Voltage RRIO
4	SGM8273-4	1	2	10	No	3.3 ~ 36	4	6	1.5	9	600	90	86	Yes	Yes	SOIC-14	Low Noise, High Precision, High Voltage RRIO
1	SGM8240-1	1	3	5	No	2.7 ~ 24	0.1	0.05	3	100	2.8	120	110	Yes	Yes	SOT-23-5,SC70-5	High Voltage, Precision, Micro Power, Low Noise
2	SGM8240-2	1	3	5	No	2.7 ~ 24	0.1	0.05	3	100	2.8	120	110	Yes	Yes	SOIC-8,MSOP-8,TDFN-2×3-8L	High Voltage, Precision, Micro Power, Low Noise

Note: †† Typical Values @ 100kHz

Low Noise Operational Amplifiers

The Low Noise Operational Amplifier family provides rail-to-rail input and output with an excellent speed/power consumption ratio. They are designed to provide optimal performance in low noise systems, providing rail-to-rail output swing into heavy loads. The combination of these characteristics makes them extremely suitable for sensor interfaces, high speed current sensing and active filtering.

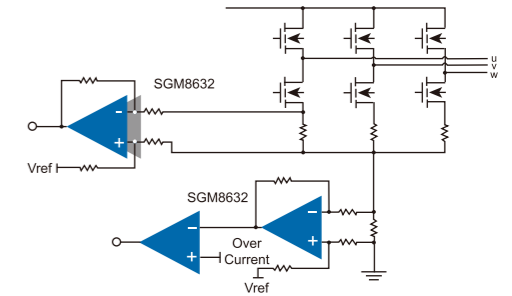

Amplifiers per Package	Part Number	1 ⁺		Slew Rate	I _{OUT}	V _{OS}	TC of V _{OS}	I _B Typ	V _{CC}	I _Q /Amp Typ	A _{VO} Typ	CMRR	Rail-to-Rail I/O	Package	Features	
		E _{NOISE} Typ @1kHz (nV/√Hz)	I _{NOISE} Typ @1kHz (pA/√Hz)													GBP Typ (MHz)
1	SGM8261-1	1.6	6	16	16	65 [†]	0.35	1	40000	3.6 ~ 36	3.8	140	135	Output	SOIC-8	16MHz, Ultra Low Noise, HiFi Audio Amp
2	SGM8261-2	1.6	6	16	16	65 [†]	0.35	1	40000	3.6 ~ 36	3.8	140	135	Output	TDFN-3x3-8BL,SOIC-8,MSOP-8	16MHz, Ultra Low Noise, HiFi Audio Amp
2	SGM8261-5	1.6	6	16	16	110 [†]	0.35	1	40000	3.6 ~ 36	4.1	150	136	Output	TDFN-3x3-10L,MSOP-10	16MHz, Ultra Low Noise, HiFi Audio Amp
2	SGM8264-2	1.6	6	16	16	110 [†]	0.35	1	40000	3.6 ~ 36	4.1	140	120	Output	SOIC-8	16MHz, Ultra Low Noise, HiFi Audio Amp
2	SGM8262-2	3.5 ^{†††}	4 ^{†††}	50	33	200 [†]	0.5	0.5	40000	4.5 ~ 36	9	110	125	Output	SOIC-8,TDFN-3x3-8BL	50MHz, Ultra Low Noise, HiFi High Output Current Audio Amp
1	SGM8263-1	4.5	5	10	10	36	0.0085	0.01	60000	4 ~ 36	2.5	145	135	Output	SOT-23-5,SOIC-8	10MHz, Ultra Low Noise, Ultra Low Offset
1	SGM8295-1	4.5	2	9	8	28	0.25	0.4	1000	3.6 ~ 36	1.5	130	140	Output	SOIC-8,SOT-23-5	9MHz, Low Noise, High Voltage Amp
1	SGM8965-1	4.5 ^{†††}	0.125 ^{††††}	50	30	70 [†]	0.25	1.2	0.5	2.2 ~ 5.5	5.3	115	100	Yes	SOT-23-5,SOIC-8	50MHz, High Precision Amp
2	SGM8263-2	4.5	5	10	10	36	0.0085	0.01	60000	4 ~ 36	2.5	145	135	Output	SOIC-8	10MHz, Ultra Low Noise, Ultra Low Offset
2	SGM8295-2	4.5	2	9	8	28	0.25	0.4	1000	3.6 ~ 36	1.5	130	140	Output	SOIC-8,MSOP-8	9MHz, Low Noise, High Voltage Amp
2	SGM8965-2	4.5 ^{†††}	0.125 ^{††††}	50	30	70 [†]	0.25	1.2	0.5	2.2 ~ 5.5	5.3	115	100	Yes	SOIC-8,MSOP-8	50MHz, High Precision Amp
4	SGM8295-4	4.5	2	9	8	28	0.25	0.4	1000	3.6 ~ 36	1.5	130	140	Output	SOIC-14	9MHz, Low Noise, High Voltage Amp
2	SGM5532	5	1	20	18	27	0.5	0.6	550000	5 ~ 36	4.25	140	140	Output	SOIC-8	High Voltage, Low Noise
1	SGM8959-1	8		4	1	25	0.01	0.032	350	1.8 ~ 5.5	380	127	123	Yes	SOT-23-5,SC70-5,SOIC-8	High Precision, Low Noise, Zero-Drift
2	SGM8959-2	8		4	1	25	0.01	0.032	350	1.8 ~ 5.5	380	127	123	Yes	SOIC-8,TDFN-3x3-8L	High Precision, Low Noise, Zero-Drift
1	SGM8275-1	8.5	1.5	0.6	3	34 [†]	0.035 [†]	0.3	1000	3.6 ~ 36	0.75	130	140	Output	SOT-23-5	600kHz, Low Noise, High Voltage Amp
1	SGMOP07E	8.5	1.5	0.6	3	21	0.15	0.3	1000	3.6 ~ 36	0.75	130	140	Output	SOIC-8	High Voltage, High Precision, Low Noise, Rail-to-Rail Output
2	SGM8275-2	8.5	1.5	0.6	3	34 [†]	0.035 [†]	0.3	1000	3.6 ~ 36	0.75	130	140	Output	SOIC-8	600kHz, Low Noise, High Voltage Amp
1	SGM8651	8.7 ^{††}		50	66	100	8	4.5	6	2.5 ~ 5.5	2.3	80	80	Output	SOT-23-5,SOIC-8	50MHz, 66V/μs, Low Noise, Rail-to-Rail Output
1	SGM8653	8.7 ^{††}		50	66	100	8	4.5	6	2.5 ~ 5.5	2.3	80	80	Output	SOT-23-6,SOIC-8	50MHz, 66V/μs, Low Noise, Single Amp with Shutdown, Rail-to-Rail Output
2	SGM8652	8.7 ^{††}		50	66	100	8	4.5	6	2.5 ~ 5.5	2.3	80	80	Output	SOIC-8,MSOP-8	50MHz, 66V/μs, Low Noise, Rail-to-Rail Output
2	SGM8655	8.7 ^{††}		50	66	100	8	4.5	6	2.5 ~ 5.5	2.3	80	80	Output	MSOP-10	50MHz, 66V/μs, Low Noise, Dual Amps with Shutdown, Rail-to-Rail Output
4	SGM8654	8.7 ^{††}		50	66	100	8	4.5	6	2.5 ~ 5.5	2.3	80	80	Output	SOIC-14,TSSOP-14	50MHz, 66V/μs, Low Noise, Rail-to-Rail Output
1	SGM8273-1	9	0.7	4	6	18	1	2	10	3.3 ~ 36	0.6	90	86	Yes	SOT-23-5,SOIC-8,MSOP-8	High Voltage, Precision, RRIO
2	SGM8273-2	9	0.7	4	6	18	1	2	10	3.3 ~ 36	0.6	90	86	Yes	SOIC-8	High Voltage, Precision, RRIO
4	SGM8273-4	9	0.7	4	6	18	1	2	10	3.3 ~ 36	0.6	90	86	Yes	SOIC-14	High Voltage, Precision, RRIO
1	SGM8276-1	10	0.5	10	8	40	1.5	1	50	3.3 ~ 36	1.4	120	80	Yes	SOT-23-5	Low Noise, High Precision, High Voltage, RRIO
2	SGM8276-2	10	0.5	10	8	40	1.5	1	50	3.3 ~ 36	1.4	120	80	Yes	SOIC-8	Low Noise, High Precision, High Voltage, RRIO
4	SGM8276-4	10	0.5	10	8	40	1.5	1	50	3.3 ~ 36	1.4	120	80	Yes	SOIC-14	Low Noise, High Precision, High Voltage, RRIO
1	SGM8958-1	12		1.8	0.7	17	0.01	0.03	500	1.8 ~ 5.5	165	136	125	Yes	SOT-23-5,SC70-5,SOIC-8	High Precision, Low Noise, Zero-Drift
2	SGM8958-2	12		1.8	0.7	17	0.01	0.03	500	1.8 ~ 5.5	165	136	125	Yes	SOIC-8,TDFN-3x3-8L	High Precision, Low Noise, Zero-Drift

Notes: † Typical Values @ 25°C
 †† Typical Values @ 1MHz
 ††† Typical Values @ 100kHz
 †††† Typical Values @ 10kHz

Low Noise Operational Amplifiers

Amplifiers per Package	2* Part Number	1* E _{NOISE} Typ @1kHz (nV/√Hz)	I _{NOISE} Typ @1kHz (pA/√Hz)	GBP Typ (MHz)	Slew Rate Typ (V/μs)	I _{OUT} Min @25°C (mA)	V _{OS} Max @25°C (mV)	TC of V _{OS} Typ (μV/°C)	I _B Typ (pA)	V _{CC} (V)	I _Q /Amp Typ (mA)	A _{VO} Typ (dB)	CMRR Typ (dB)	Rail-to -Rail I/O	Package	Features
4	SGM8634	12	0.003	6	3.7	49	3.5	2.4	1	2.5 ~ 5.5	0.47	97	83	Yes	SOIC-14,TSSOP-14	6MHz, 3.7V/μs, Low Noise, RRIO
1	SGM721	12.5		11	8.5	52	4	2.1	1	2.1 ~ 5.5	1.2	89	75	Yes	SOT-23-5,SOIC-8,SC70-5	11MHz, 8.5V/μs, Low Noise, RRIO
1	SGM723	12.5		11	8.5	52	4	2.1	1	2.1 ~ 5.5	1.2	89	75	Yes	SOT-23-6,SOIC-8	11MHz, 8.5V/μs, Low Noise, Single Amp with Shutdown, RRIO
2	SGM722	12.5		11	8.5	52	4	2.1	1	2.1 ~ 5.5	1.1	89	75	Yes	SOIC-8,MSOP-8,TSSOP-8	11MHz, 8.5V/μs, Low Noise, RRIO
4	SGM724	12.5		11	8.5	52	4	2.1	1	2.1 ~ 5.5	1.1	89	75	Yes	SOIC-14,TSSOP-14	11MHz, 8.5V/μs, Low Noise, RRIO
1	SGM8631	13		6	3.7	40	3.5	2.4	1	2 ~ 5.5	0.57	86	76	Yes	SOT-23-5,SOIC-8,SC70-5	6MHz, 3.7V/μs, Low Noise, RRIO
1	SGM8633	13		6	3.7	40	3.5	2.4	1	2 ~ 5.5	0.57	86	76	Yes	SOT-23-6,SOIC-8	6MHz, 3.7V/μs, Low Noise, Single Amp with Shutdown, RRIO
2	SGM8632	13		6	3.7	40	3.5	2.4	1	2 ~ 5.5	0.48	86	76	Yes	MSOP-8,SOIC-8	6MHz, 3.7V/μs, Low Noise, RRIO
2	SGM8270-2	15	0.3	2.5	8	28	2.8	0.8	10	3.3 ~ 36	0.5	120	85	Yes	SOIC-8,MSOP-8	Precision, High Voltage, RRIO
4	SGM8270-4	15	0.3	2.2	8	28	1.2	0.8	5	3.3 ~ 36	0.5	120	88	Yes	SOIC-14,TSSOP-14	Precision, High Voltage, RRIO
1	SGM8621	17.5		3	1.7	38	3	2.7	1	2 ~ 5.5	0.27	90	71	Yes	SOT-23-5,SOIC-8,SC70-5	3MHz, 1.7V/μs, Low Noise, RRIO
1	SGM8623	17.5		3	1.7	38	3	2.7	1	2 ~ 5.5	0.27	90	71	Yes	SOT-23-6,SOIC-8	3MHz, 1.7V/μs, Low Noise, Single Amp with Shutdown, RRIO
2	SGM8622	17.5		3	1.7	38	3	2.7	1	2 ~ 5.5	0.21	90	71	Yes	SOIC-8,MSOP-8	3MHz, 1.7V/μs, Low Noise, RRIO
4	SGM8624	17.5		3	1.7	38	3	2.7	1	2 ~ 5.5	0.21	90	71	Yes	SOIC-14,TSSOP-14	3MHz, 1.7V/μs, Low Noise, RRIO
1	SGM8967-1	18		27	30	48	0.24	1	3	2.1 ~ 5.5	2.7	128	105	Yes	SOT-23-5,SOIC-8	27MHz, High Precision, RRIO
1	SGM8968-1	18		10	20	31	0.24	1	6	1.8 ~ 5.5	1.6	128	95	Yes	SOT-23-5,SOIC-8	10MHz, High Precision, RRIO
2	SGM8967-2	18		27	30	48	0.24	1	3	2.1 ~ 5.5	2.7	128	105	Yes	SOIC-8,MSOP-8	27MHz, High Precision, RRIO
2	SGM8968-2	18		10	20	31	0.24	1	6	1.8 ~ 5.5	1.6	128	95	Yes	SOIC-8,MSOP-8	10MHz, High Precision, RRIO
4	SGM8967-4	18		27	30	48	0.24	1	3	2.1 ~ 5.5	2.7	128	105	Yes	SOIC-14,TSSOP-14	27MHz, High Precision, RRIO
4	SGM8968-4	18		10	20	31	0.24	1	6	1.8 ~ 5.5	1.6	128	95	Yes	SOIC-14,TSSOP-14	10MHz, High Precision, RRIO
1	SGM8969-1	20		50	20	30	0.24	1	6	1.8 ~ 5.5	1.1	127	102	Yes	SOT-23-5	50MHz, High Precision, RRIO
2	SGM8969-2	20		50	20	30	0.24	1	6	1.8 ~ 5.5	1.1	127	102	Yes	SOIC-8, TDFN-3×3-8L	50MHz, High Precision, RRIO

Special Function Operational Amplifiers

Amplifiers per Package	Part Number	1*		Slew Rate Typ (V/ μ s)	I_{OUT} Typ (mA)	V_{OS} Max @25°C (mV)	TC of V_{OS} Typ (μ V/ $^{\circ}$ C)	I_B Typ (pA)	V_{CC} (V)	I_Q /Amp Typ (μ A)	A_{VO} Typ (dB)	CMRR Typ (dB)	Rail-to- -Rail I/O	Package	Features
		Settling Time to 0.1% (μ s)	GBP Typ (MHz)												
2	SGM4822		2.6 @-3dB	4.8	100				3.3 ~ 5.5	660	20		Output	SOT-23-8	Tiny, Low-Cost, Single Input, Fixed-Gain Microphone Amplifier with Integrated Bias
2	SGM4823		2.6 @-3dB	4.8	100				3.3 ~ 5.5	660	20		Output	MSOP-10	Tiny, Low-Cost, Dual Input, Fixed-Gain Microphone Amplifier with Integrated Bias
1	SGM620		0.14 @-3dB ^{†††}	1.25	24	0.05 [†]	0.22	15000	4.6 ~ 36	1300		92	Output	SOIC-8	High Voltage, Low Noise, Rail-to-Rail Output Instrumentation Amplifier
1	SGM621		0.14 @-3dB ^{†††}	1.25	24	0.05 [†]	0.22	15000	4.6 ~ 36	1300		92	Output	SOIC-8,MSOP-8,TDFN-3x3-8L	High Voltage, Low Noise, Rail-to-Rail Output Instrumentation Amplifier
2	SGM8039-2		0.012	0.004	20	0.08 [†]		5	1.4 ~ 5.5	1.5	120	96	Yes	MSOP-10	Very Low Quiescent Current, Integrated Special Switch, RRIO
1	SGM8139		0.011	0.0058	50	1.6			1.4 ~ 5.5	6.5	92	78		SOIC-16,TQFN-2.5x2.5-16L	Low Power, Low Voltage PIR and Vibration Sensor AFE
3	SGM8140		0.005	0.0016	24	2.5	2	1	1.4 ~ 5.5	1.1	93	83	Yes	TQFN-4x4-16L	Low Power, Vibration Sensor and PIR Sensor Analog Front End (AFE)
1	SGM8198	15	0.48 @-3dB ^{††}			0.55	1	1.6×10^7	2.7 ~ 36	65		140	No	SOT-23-5	High Voltage, High-side Measurement Current Shunt Monitor
1	SGM8199A0		0.074 @-3dB	0.42		0.6	1	3×10^7	2.7 ~ 26	85		97	No	SC70-6	Voltage Output, High or Low Side Measurement, Bi-Directional Current Shunt Monitor
1	SGM8199A1		0.08 @-3dB	0.35		0.35	1	1.6×10^7	2.7 ~ 26	85		104	No	SC70-6	Voltage Output, High or Low Side Measurement, Bi-Directional Current Shunt Monitor
1	SGM8199A2		0.068 @-3dB	0.3		0.25	1	1.6×10^7	2.7 ~ 26	85		108	No	SC70-6	Voltage Output, High or Low Side Measurement, Bi-Directional Current Shunt Monitor
1	SGM8477-1B		0.15 @-3dB	0.4	50	0.01	0.02		1.8 ~ 5.5	380		108	Yes	SC70-6,UTQFN-1.8x1.4-10L	1.8V to 5.5V, Low Noise, Zero-Drift Operational Amplifier
1	SGM8477-1G		0.032 @-3dB	0.15	50	0.01	0.02		1.8 ~ 5.5	380		108	Yes	SC70-6,UTQFN-1.8x1.4-10L	1.8V to 5.5V, Low Noise, Zero-Drift Operational Amplifier
1	SGM8478-1C		0.23 @-3dB	2.1	64	0.016	0.14		4.5 ~ 36	1550		106	Output	SOIC-8,TDFN-3x3-8L	High Voltage, High Precision, Low Noise, Over the Rail Difference Amplifier
1	SGM8478-1H		0.04 @-3dB	1	40	0.01 [†]		8×10^6	4.5 ~ 36	5000		102	Output	SOIC-8,TDFN-3x3-8L	High Voltage, High Precision, Low Noise, Over the Rail Difference Amplifier
2	SGM8480-2	0.7	7.5	6	85	0.025	0.2	500	4.5 ~ 18	2100	145	140	Output	TSSOP-14	15V Single-Supply, Dual Operation Amplifier with $\pm 10V$ Output Range
1	SGM8941	2	1.5	0.8	35	0.9	3	3	1.8 ~ 5.5	120	90	90	Yes	SOT-23-5,SOIC-8	Crossover Distortion Free, 0.9mV V_{OS} , Low Bias Current
2	SGM8942	2	1.5	0.8	35	0.9	3	3	1.8 ~ 5.5	120	90	90	Yes	SOIC-8,MSOP-8	Crossover Distortion Free, 0.9mV V_{OS} , Low Bias Current

Notes: † Typical Values @ 25°C
 †† Typical Values @ G = 10
 ††† Typical Values @ G = 100

High Output Current Operational Amplifiers

Amplifiers per Package	Part Number	1*		Slew Rate Typ (V/μs)	I _{OUT} Typ (mA)	V _{OS} Max @25°C (mV)	TC of V _{OS} Typ (μV/°C)	I _B Typ (pA)	V _{CC} (V)	I _O /Amp Typ (μA)	A _{VO} Typ (dB)	CMRR Typ (dB)	Rail-to-Rail I/O	Package	Features	
		Transient Output Peak Current (mA)	Settling Time to 0.1% (μs)													
1	SGM8557-1	240	15	7	240	0.005	0.027	100	2.7 ~ 5.5	1150	144	120	Output	SOT-23-5,SOIC-8,MSOP-8	High Precision, Low Noise, Zero-Drift	
2	SGM8557-2	240	15	7	240	0.005	0.027	100	2.7 ~ 5.5	1150	144	120	Output	SOIC-8	High Precision, Low Noise, Zero-Drift	
1	SGM8557-3	240	15	7	240	0.005	0.027	100	2.7 ~ 5.5	1150	144	120	Output	SOT-23-6,SOIC-8	High Precision, Low Noise, Zero-Drift, Single Amp with Shutdown	
2	SGM8557-5	240	15	7	240	0.005	0.027	100	2.7 ~ 5.5	1150	144	120	Output	MSOP-10	High Precision, Low Noise, Zero-Drift	
1	SGM8425	336	0.34	9	14	80	6.5	4.9	4.5 ~ 30	1600	92	71	Yes	SOT-23-5,SOIC-8,MSOP-8	336mA Peak Output Current, 14V/μs, 30V _{CC} , Single V _{COM} Buffer	
2	SGM8426	336	0.34	9	14	80	6.5	4.9	4.5 ~ 30	1600	92	71	Yes	SOIC-8,MSOP-8	336mA Peak Output Current, 14V/μs, 30V _{CC} , Dual V _{COM} Buffer	
4	SGM8428	336	0.34	9	14	80	6.5	4.9	4.5 ~ 30	1600	92	71	Yes	SOIC-14,TSSOP-14	336mA Peak Output Current, 14V/μs, 30V _{CC} , Quad V _{COM} Buffer	
1	SGM8416-1	800	0.16	25	65	300	10	3.6	1000	4.5 ~ 26.5	2600	120	72	Yes	TDFN-3×3-8L	0.8A Peak Output Current, 65V/μs, 26.5V _{CC} , Single V _{COM} Buffer
2	SGM8416-2	800	0.16	25	65	300	10	3.6	1000	4.5 ~ 26.5	2600	120	72	Yes	MSOP-8 (Exposed Pad)	0.8A Peak Output Current, 65V/μs, 26.5V _{CC} , Dual V _{COM} Buffer
4	SGM8416-4	800	0.16	25	65	300	10	3.6	1000	4.5 ~ 26.5	2600	120	72	Yes	TSSOP-14 (Exposed Pad)	0.8A Peak Output Current, 65V/μs, 26.5V _{CC} , Quad V _{COM} Buffer
1	SGM8417-1	1500	0.14	28	65	400	10	3.6	1000	4.5 ~ 26.5	3300	120	72	Yes	TDFN-3×3-8L	1.5A Peak Output Current, 65V/μs, 26.5V _{CC} , Single V _{COM} Buffer
2	SGM8417-2	1500	0.14	28	65	400	10	3.6	1000	4.5 ~ 26.5	3300	120	72	Yes	MSOP-8 (Exposed Pad)	1.5A Peak Output Current, 65V/μs, 26.5V _{CC} , Dual V _{COM} Buffer
4	SGM8417-4	1500	0.14	28	65	400	10	3.6	1000	4.5 ~ 26.5	3300	120	72	Yes	TSSOP-14 (Exposed Pad)	1.5A Peak Output Current, 65V/μs, 26.5V _{CC} , Quad V _{COM} Buffer
2	SGM8423-2A	2000		63	104/63	210	10/3.5		100/160	5 ~ 24	145/20500	106/86	104/106	No	TQFN-4×4-20L	High Speed, Low Noise, 2A PLC Driver
1	SGM8418-1	3000	0.14	28	65	400	10	3.6	1000	4.5 ~ 26.5	4800	120	72	Yes	TDFN-3×3-8L	3A Peak Output Current, 65V/μs, 26.5V _{CC} , Single V _{COM} Buffer
2	SGM8418-2	3000	0.14	28	65	400	10	3.6	1000	4.5 ~ 26.5	4800	120	72	Yes	MSOP-8 (Exposed Pad)	3A Peak Output Current, 65V/μs, 26.5V _{CC} , Dual V _{COM} Buffer
4	SGM8418-4	3000	0.14	28	65	400	10	3.6	1000	4.5 ~ 26.5	4800	120	72	Yes	TSSOP-14 (Exposed Pad)	3A Peak Output Current, 65V/μs, 26.5V _{CC} , Quad V _{COM} Buffer
1	SGM8421-1	3000	0.14	28	65	400	10	3.5	1000	4.5 ~ 26.5	4800	120	72	Yes	TO-263-A	High Speed, Low Noise, 400mA Continuous Output Current Resolver Driver
2	SGM8422			2.4	2	80	6		10	4.5 ~ 30	720	115	81	Yes	SOIC-8,MSOP-8	Low Power, 30V _{CC} , Dual V _{COM} Buffer for Small Panel
4	SGM8424			2.4	2	80	6		10	4.5 ~ 30	720	115	81	Yes	SOIC-14,TSSOP-14	Low Power, 30V _{CC} , Quad V _{COM} Buffer for Small Panel

Tiny Package Operational Amplifiers

Amplifiers per Package	Part Number	Estimated Package Size (W×L) (mm ²)	V _{OS} Max @25°C (mV)	TC of V _{OS} Typ (μV/°C)	GBP Typ (MHz)	A _{VO} Typ (dB)	I _B Typ (pA)	V _{CC} (V)	I _O /Amp Typ (μA)	Settling Time to 0.1% (μs)	Slew Rate Typ (V/μs)	I _{OUT} Typ (mA)	CMRR Typ (dB)	Rail-to-Rail I/O	Package	Features
1	SGM8604-1	1.45	0.01	0.017	15	145	200	2.7 ~ 5.5	1200		7	232	120	No	UTDFN-1.45×1-6L	15MHz, 7V/μs, High-Output-Drive, High Precision, Low Noise, Single Amp
1	SGM8604-3	1.45	0.01	0.017	15	145	200	2.7 ~ 5.5	1200		7	232	120	No	UTDFN-1.45×1-6L	15MHz, 7V/μs, High-Output-Drive, High Precision, Low Noise, Single Amp with Shutdown
1	SGM8605-1	1.45	4.5		12.5	88	2	2.1 ~ 5.5	1200	0.21	8.5	78	79	Yes	UTDFN-1.45×1-6L	Ultra Tiny Package, Low Noise
2	SGM8558-2	2.1	0.015	0.013	15	139	600	2.8 ~ 5.5	860		8	230	126	No	TDFN-3×3-8L,SOIC-8,WLCSP-1.45×1.45-8B	High Precision, Low Noise, Zero-Drift
2	SGM8278-2	2.46	0.4†		3.5	110	10	3 ~ 36	1500		2	80	80	Yes	TDFN-2×2-8AL,TDFN-3×3-8BL,WLCSP-1.57×1.57-8B	Low Noise, High Voltage, RRIO
1	SGM8954-1	2.56	0.035	0.055	0.11	125	60	1.8 ~ 5.5	9		0.04	8	108	Yes	SOT-23-5,SOIC-8,UTDFN-1.6×1.6-6L	Ultra Low Power, CMOS, Zero-Drift, RRIO
1	SGM8212-1	2.56	0.5†		2.5	140	5	2.7 ~ 36	475	15	1.5	30	115	Yes	SOT-553-5,SOT-23-5,SOIC-8	Low Noise, High Voltage, RRIO
1	SGM8049-1	4	0.85	0.6	0.12	118	1	1.8 ~ 5.5	2.5		0.08	20	100	Yes	SC70-5,SOT-23-5,TDFN-2×2-6L	Pico Amp Input Current, Micro Power, RRIO
1	SGM8601	4	4	8.7	11	92	1	2.1 ~ 5.5	1100	0.21	8.5	63	82	Yes	TDFN-2×2-8L	Tiny Package, Low Noise
1	SGM8603	4	4.9	2.7	11	91	1	2.1 ~ 5.5	1100	0.21	8.5	64	83	Yes	TDFN-2×2-6L	Tiny Package, Low Noise
2	SGM4832	4	3.5	2.7	1.1	105	0.5	2.1 ~ 5.5	46	5.3	0.52	75	80	Yes	TDFN-2×2-8L	1.1MHz, 46μA, CMOS, RRIO
2	SGM8040-2	4	0.23	1	0.011	120	10	1.4 ~ 5.5	0.55		0.004	18	92	Yes	SOIC-8,TDFN-2×2-8L	High Precision, Unity-Gain Stable, RRIO
2	SGM8600	4	4	8.7	11	92	1	2.1 ~ 5.5	1100	0.21	8.5	63	82	Yes	TDFN-2×2-8L,SOIC-8	Tiny Package, Positive Offset, Low Noise
2	SGM8956	4	0.05	0.08	0.35	121	130	1.8 ~ 5.5	20		0.18	60	100	Yes	SOIC-8,MSOP-8,TDFN-3×3-8L,TDFN-2×2-8L	High Precision, Low Noise, Micro Power, RRIO
2	SGM8954-2	4	0.035	0.055	0.11	125	60	1.8 ~ 5.5	9		0.04	8	108	Yes	SOIC-8,MSOP-8,TDFN-2×2-8L	Ultra Low Power, CMOS, Zero-Drift, RRIO
2	SGM8210-2	6	1	1	1	120	5	3.3 ~ 24	50		0.3		115	Yes	TDFN-2×3-8L,SOIC-8,MSOP-8	High Voltage, Micro Power, Precision
2	SGM8240-2	6	1	3	0.1	120	5	2.7 ~ 24	2.8		0.05	20	110	Yes	TDFN-2×3-8L,SOIC-8,MSOP-8	High Voltage, Micro Power, Precision
2	SGM8602	6	5.1	4.7	12	92	1	2.1 ~ 5.5	1100	0.2	9	65	75	Yes	SOT-23-8,TDFN-2×3-8L	Tiny Package, Low Noise
2	SGM8604-2	6	0.01	0.017	15	145	200	2.7 ~ 5.5	1200		7	232	120	No	TDFN-2×3-8AL	15MHz, 7V/μs, High-Output-Drive, High Precision, Low Noise, Dual Amps
1	SGM8606	9	0.05	0.08	0.35	121	130	1.8 ~ 5.5	20		0.18	18	100	Yes	TDFN-3×3-10L	Current Sensing AFE
2	SGM4834	9	2.6	1.7	10	109		3 ~ 5.5	5500		5.4	212	103	No	TDFN-3×3-10L	Motor/Headset Driver with Shutdown
2	SGM4835	9	5.3	2.7	1.5	84	10	2.1 ~ 5.5	60	3.6	0.63	21	70	Yes	TDFN-3×3-8L	Stereo Headphone Driver
2	SGM8261-2	9	0.35	1	16	140	40000	3.6 ~ 36	3800		16	65	135	No	SOIC-8,MSOP-8,TDFN-3×3-8BL	16MHz, Ultra Low Noise, HiFi Audio Amp
2	SGM8261-5	9	0.35	1	16	150	40000	3.6 ~ 36	4100		16	110	136	No	MSOP-10,TDFN-3×3-10L	16MHz, Ultra Low Noise, HiFi Audio Amp
2	SGM8604-5	9	0.01	0.017	15	145	200	2.7 ~ 5.5	1200		7	232	120	No	TDFN-3×3-10L	15MHz, 7V/μs, High-Output-Drive, High Precision, Low Noise, Dual Amps with Shutdown
2	SGM8957-2	9	0.025	0.08	0.35	121	130	1.8 ~ 5.5	20		0.18	60	100	Yes	SOIC-8,MSOP-8,TDFN-3×3-8L	High Precision, Low Noise, Micro Power, RRIO
2	SGM8958-2	9	0.01	0.03	1.8	136	500	1.8 ~ 5.5	165		0.7		125	Yes	SOIC-8,TDFN-3×3-8L	High Precision, Low Noise, Zero-Drift
2	SGM8959-2	9	0.01	0.032	4	127	350	1.8 ~ 5.5	380		1		123	Yes	SOIC-8,TDFN-3×3-8L	High Precision, Low Noise, Zero-Drift
4	SGM3130	9	5	2.7	1	84	10	2.1 ~ 5.5	60	5.3	0.52	75	68	Yes	TQFN-3×3-16L	1MHz, 60μA, CMOS, RRIO
4	SGM8044	9	2.5	2.5	0.015	93	1	1.4 ~ 5.5	0.67		0.0034	23	83	Yes	SOIC-14,TSSOP-14,TQFN-3×3-16L	Very Low Quiescent Current, RRIO
4	SGM8424	9	6		2.4	115	10	4.5 ~ 30	720		2	80	81	Yes	SOIC-14,TSSOP-14,TQFN-3×3-16L	Low Power, 30V _{CC} , Quad V _{COM} Buffer for Small Panel
3	SGM8140	16	2.5	2	0.005	93	1	1.4 ~ 5.5	1.1		0.0016	24	83	Yes	TQFN-4×4-16L	PIR Sensor AFE Integrate Dual Amps and Single Comp

Note: † Typical Values @ 25°C

Nano Power Comparators

The Nano Power Comparator family provides a typical power supply current as low as 325nA. They have the best-in-class power supply current versus propagation delay performance. The propagation delay is as low as 6µs with 100mV overdrive at 1.4V supply. The Nano Power Comparator family also provides different options featuring push-pull output stage, PFET/NFET open-drain output stage, latch enable, reference output and ultra small DFN packages.

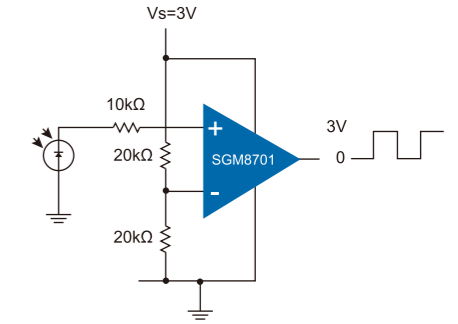

Comparators per Package	Part Number	I _Q /Comp Typ (nA)	Latch Enable	V _{CC} (V)	V _{OS} Max @25°C (mV)	t _{PD} , H to L @V _{CC} = 5V (µs)	t _{PD} , L to H @V _{CC} = 5V (µs)	Logic Output	Reference Output (V)	Rise Time @V _{CC} = 5V (ns)	Fall Time @V _{CC} = 5V (ns)	Package	Features
1	SGM8713A-1	325	No	1.6 ~ 5.5	1.1†			Push-Pull		7.2	15	XTDFN-0.8×0.8-4L	Small Size, Nano Power, Push-Pull
1	SGM8713B-1	325	No	1.6 ~ 5.5	1.1†	2.7	4.8	Open-Drain			15	XTDFN-0.8×0.8-4L	Small Size, Nano Power, Open-Drain
1	SGM8701	350	No	1.4 ~ 5.5	3	6	33	Push-Pull	NA	85	60	SOT-23-5,SC70-5	Ultra Low Power, Push-Pull, Small Package
1	SGM8702	350	No	1.4 ~ 5.5	3	6	33	Open-Drain (PFET)	NA	85	NA	SOT-23-5,SC70-5	Ultra Low Power, PFET Open-Drain, Small Package
1	SGM8703	350	Yes	1.4 ~ 5.5	3	6	33	Push-Pull	NA	85	60	SOT-23-6	Latch Enable, Ultra Low Power, Push-Pull, Small Package
1	SGM8704	350	Yes	1.4 ~ 5.5	3	6	33	Push-Pull & Invert	NA	85	60	SOIC-8,MSOP-8	Latch Enable, Ultra Low Power, Push-Pull and Inverter
2	SGM8705	350	No	1.4 ~ 5.5	3	6	33	Push-Pull	NA	85	60	SOIC-8,MSOP-8	Ultra Low Power, Push-Pull
1	SGM8707	350	No	1.4 ~ 5.5	3	6	33	Push-Pull	NA	85	60	SOT-23-5,SC70-5	Ultra Low Power, Push-Pull, Small Package
1	SGM8709	350	No	1.4 ~ 5.5	3	5		Open-Drain (NFET)	NA	NA	36	SOT-23-5,SC70-5	Ultra Low Power, NFET Open-Drain, Small Package
2	SGM8712	350	No	1.4 ~ 5.5	3	6	33	Push-Pull	NA	85	60	MSOP-8	Ultra Low Power, Push-Pull
1	SGM8706	2300	Yes	1.8 ~ 5.5	3	5.6	30	Push-Pull	1.2	40	30	SOIC-8,SOT-23-8,SOT-23-6	Internal Reference, Latch Enable, Ultra Low Power, Push-Pull
1	SGM8708	2300	Yes	1.8 ~ 5.5	3	5.6	30	Push-Pull & Invert	1.2	40	30	SOT-23-8,SOIC-8	Internal Reference, Latch Enable, Ultra Low Power, Push-Pull and Inverter
1	SGM8710	2300	Yes	1.8 ~ 5.5	3	5.6		Open-Drain (NFET)	1.2	NA	30	SOT-23-8,SOT-23-6	Internal Reference, Latch Enable, Ultra Low Power, NFET Open-Drain
1	SGM8711	2300	No	1.8 ~ 5.5	3	5.6	30	Push-Pull	1.2	40	30	UTDFN-1.6×1.6-6L	Tiny Package, Internal Reference, Ultra Low Power, Push-Pull

Note: † Typical Values @ 25°C

High Speed Comparators

The High Speed Comparator family provides the smallest propagation delay as short as 6ns, while input common mode range of the devices extends beyond both power supply rails. The output pulls to within 0.1V of either supply rail without external pull-up circuitry, making the devices ideal for interface with both CMOS and TTL logics. All input and output pins can tolerate a continuous short-circuit fault condition to either rail. Internal hysteresis ensures a clean output switching, even with slow-moving input signals.

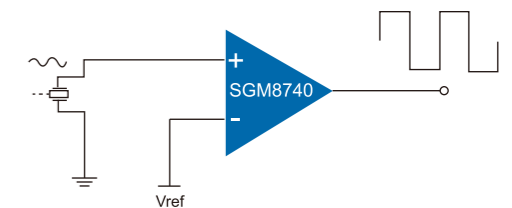

Comparators per Package	Part Number	t _{PD} , H to L @V _{CC} = 5V (ns)	t _{PD} , L to H @V _{CC} = 5V (ns)	Rise Time @V _{CC} = 5V (ns)	Fall Time @V _{CC} = 5V (ns)	V _{OS} Max @25°C (mV)	V _{CC} (V)	Input Common Mode Voltage Range (V)	I _Q /Comp Typ (µA)	Logic Output	Rail-to-Rail Output	Package	Features
1	SGM8743	6†	6†	8†	6†	5	2.7 ~ 5.5	-0.1 ~ Vs+0.1	1300	Push-Pull	Yes	SOT-23-5,SC70-5	Ultra High Speed, Small Package, Single, Rail-to-Rail Input
1	SGM8744	6†	6†	8†	6†	5	2.7 ~ 5.5	-0.1 ~ Vs+0.1	1300	Push-Pull	Yes	SOT-23-5,SC70-5	Ultra High Speed, Small Package, Single, Rail-to-Rail Input
2	SGM8745	6†	6†	8†	6†	5	2.7 ~ 5.5	-0.1 ~ Vs+0.1	1300	Push-Pull	Yes	SOIC-8,MSOP-8	Ultra High Speed, Small Package, Dual, Rail-to-Rail Input
1	SGM8740	20†	25†	8†	5†	5	2.7 ~ 5.5	-0.1 ~ Vs+0.1	155	Push-Pull	Yes	SOT-23-5,SC70-5	High Speed, Small Package, Single, Rail-to-Rail Input
1	SGM8741	20†	25†	8†	5†	5	2.7 ~ 5.5	-0.1 ~ Vs+0.1	155	Push-Pull	Yes	SOT-23-5,SC70-5	High Speed, Small Package, Single, Rail-to-Rail Input

Note: † Typical Values @ V_{CC} = 3V

High Speed Comparators

Comparators per Package	Part Number	1*		Rise Time @V _{CC} = 5V (ns)	Fall Time @V _{CC} = 5V (ns)	V _{OS} Max @25°C (mV)	V _{CC} (V)	Input Common Mode Voltage Range (V)	I _O /Comp Typ (μA)	Logic Output	Rail-to-Rail Output	Package	Features
		t _{PD} , H to L @V _{CC} = 5V (ns)	t _{PD} , L to H @V _{CC} = 5V (ns)										
2	SGM8742	20†	25†	8†	5†	5	2.7 ~ 5.5	-0.1 ~ V _S +0.1	155	Push-Pull	Yes	SOIC-8,MSOP-8	High Speed, Small Package, Dual, Rail-to-Rail Input
1	SGM8751	30†	22†	11†	8†	5	2.7 ~ 5.5	-0.1 ~ V _S -1.2	150	Push-Pull	Yes	SOT-23-5	Low Power, Small Package, Single, Rail-to-Rail Output
2	SGM8770	45			15	2.4	2.8 ~ 36	-V _S ~ V _S -1.5	155	Open-Drain	Yes	SOIC-8,TDFN-3×3-8L	High Voltage, High Precision, Dual, Open-Drain Output
1	SGM8771	50			12	2.4	2.8 ~ 36	-V _S ~ V _S -1.5	180	Open-Drain	Yes	SOIC-8,TDFN-3×3-8L	High Voltage, High Precision, Single, Open-Drain Output
2	SGM8773	60	60	20	20	2.4	2.8 ~ 36	-V _S ~ V _S -1.5	165	Push-Pull	Yes	SOIC-8,TDFN-3×3-8L	High Voltage, High Precision, Dual, Push-Pull Output
1	SGM8746	95†	120†	8†	6†	5	2.7 ~ 5.5	-0.1 ~ V _S +0.1	22	Push-Pull	Yes	SOT-23-5,SC70-5	Low Power, Small Package, Single, Rail-to-Rail Input
1	SGM8747	95†	120†	8†	6†	5	2.7 ~ 5.5	-0.1 ~ V _S +0.1	22	Push-Pull	Yes	SOT-23-5,SC70-5	Low Power, Small Package, Single, Rail-to-Rail Input
2	SGM8748	95†	120†	8†	6†	5	2.7 ~ 5.5	-0.1 ~ V _S +0.1	22	Push-Pull	Yes	SOIC-8,MSOP-8	Low Power, Small Package, Dual, Rail-to-Rail Input
1	SGM8749	97†	NA	NA	6	5	2.7 ~ 5.5	-0.1 ~ V _S +0.1	22	Open-Drain	No	SOT-23-5,SC70-5	Low Power, Small Package, Single, Open-Drain Output
2	SGM8750	97†	NA	NA	6	5	2.7 ~ 5.5	-0.1 ~ V _S +0.1	22	Open-Drain	No	SOIC-8,MSOP-8	Low Power, Small Package, Dual, Open-Drain Output

Note: † Typical Values @ V_{CC} = 3V

High Voltage Comparators

Comparators per Package	Part Number	1*		Rise Time @V _{CC} = 5V (ns)	Fall Time @V _{CC} = 5V (ns)	V _{OS} Max @25°C (mV)	V _{CC} (V)	Input Common Mode Voltage Range (V)	I _O /Comp Typ (μA)	Logic Output	Rail-to-Rail Output	Package	Features
		t _{PD} , H to L @V _{CC} = 5V (ns)	t _{PD} , L to H @V _{CC} = 5V (ns)										
2	SGM8770	45			15	2.4	2.8 ~ 36	-V _S ~ V _S -1.5	155	Open-Drain	Yes	SOIC-8,TDFN-3×3-8L	High Voltage, High Precision, Dual, Open-Drain Output
2	SGM8773	60	60	20	20	2.4	2.8 ~ 36	-V _S ~ V _S -1.5	155	Push-Pull	Yes	SOIC-8,TDFN-3×3-8L	High Voltage, High Precision, Dual, Push-Pull Output

Digital-to-Analog Converters

This SGM534X family DAC is designed for general purpose multi-channel high precision voltage output application, such as system bias generation, gain and offset control, positioning and control, etc.

Part Number	Resolution (Bits)	Update Rate (SPS)	Output Voltage									Output Settling Time		Operating Power-Down		Temp Range (°C)	Package	Features
			Output Channels	Range (V)	Reference	V _{DD} (V)	INL (LSB)	DNL (LSB)	Offset Error (mV)	Gain Error (% of FSR)	Gain Drift (ppm/°C)	(μs)	I _Q (μA)	I _Q (μA)				
SGM5347-8	8	90K	8	0 ~ V _{DD}	External	2.8 ~ 5.5	0.2	0.02	3	0.1	2	7	500	0.6	-40 to 125	SOIC-16,TSSOP-16	8 Channels, 8-Bit Digital-to-Analog Converter with Output Operational Amplifier	
SGM5347-10	10	83K	8	0 ~ V _{DD}	External	2.8 ~ 5.5	0.8	0.08	3	0.1	2	7	500	0.6	-40 to 125	SOIC-16,TSSOP-16	8 Channels, 10-Bit Digital-to-Analog Converter with Output Operational Amplifier	
SGM5347-12	12	77K	8	0 ~ V _{DD}	External	2.8 ~ 5.5	3	0.3	3	0.1	2	7	500	0.6	-40 to 125	SOIC-16,TSSOP-16	8 Channels, 12-Bit Digital-to-Analog Converter with Output Operational Amplifier	
SGM5348-8	8	200K	8	0 ~ V _{DD}	External	2.8 ~ 5.5	0.2	0.02	3	0.1	2	7	500	0.6	-40 to 125	TSSOP-16	8 Channels, 8-Bit Digital-to-Analog Converter with Output Operational Amplifier	
SGM5348-10	10	200K	8	0 ~ V _{DD}	External	2.8 ~ 5.5	0.8	0.08	3	0.1	2	7	500	0.6	-40 to 125	TSSOP-16	8 Channels, 10-Bit Digital-to-Analog Converter with Output Operational Amplifier	
SGM5348-12	12	140K	8	0 ~ V _{DD}	External	2.8 ~ 5.5	3	0.3	3	0.1	2	7	500	0.6	-40 to 125	TSSOP-16,TQFN-3x3-16L	8 Channels, 12-Bit Digital-to-Analog Converter with Output Operational Amplifier	
SGM5349A-16	16	140K	8	0 ~ V _{DD}	External	2.7 ~ 5.5	8	±0.4	1.5	0.4	2	7	800	1	-40 to 125	TSSOP-16,TQFN-4x4-16L	8 Channels, 16-Bit, SPI Interface, Voltage-Output Digital-to-Analog Converter	

Oversampling Analog-to-Digital Converters

This SGM58XXX family sigma-delta ADC is designed for high precision and low power consumption application, such as industrial temperature and pressure sensor conditioning, battery powered instruments and industrial field transducer.

Part Number	Resolution (Bits)	Data Rate (SPS)	Input Voltage									Operating Power-Down				Temp Range (°C)	Package	Features
			Input Channels	Range (V)	Reference	V _{DD} (V)	INL (ppmFS)	Offset Error (μV)	Gain Error (% of FSR)	Gain Drift (ppm/°C)	Programmable Gain	ENOB (Bit)	I _Q (μA)	I _Q (μA)				
SGM58031	16	6.25 ~ 960	4	0 ~ V _{DD}	Internal/External	3 ~ 5.5	16	31	0.03	30	2/3 ~ 16	16	255	0.8	-40 to 125	MSOP-10,TDFN3x3-10L	Ultra-Small, Low-Power, 16-Bit, Analog-to-Digital Converter with Internal Reference	
SGM58200	24	6.25 ~ 960	4	0 ~ V _{DD}	Internal/External	3 ~ 5.5	16	10	0.01	80	2/3 ~ 16	20.8	230	0.8	-40 to 125	MSOP-10,TDFN3x3-10L	Ultra-Small, Low-Power, 24-Bit, Analog-to-Digital Converter with Internal Reference	
SGM58601	24	2.5 ~ 60000	8	0 ~ V _{DD}	External	4.75 ~ 5.5	10	2	0.01	2	1 ~ 128	25	5000	0.8	-40 to 125	SSOP-28,TQFN-5x5-28L	Very Low Noise, 24-Bit, Analog-to-Digital Converter	

Shunt Voltage References

The voltage references (VREFs) are designed for use in precision signal chain and AC/DC applications. The high accuracy shunt VREFs provide precision in demanding system requirement for applications using high resolution data converters.

1*

Part Number	V _O (V)	Reference Voltage	Initial Accuracy Max (%)	V _O Adj Min (V)	V _O Adj Max (V)	I _Z for Regulation Min (μA)	Temperature Coefficient Max (ppm/°C)	Operating Temperature Range (°C)	I _{OUT} /I _{KA} Max (mA)	Package	Features
SGM4040	2.5	Fixed	0.2 [†]			50 [†]	20 [†]	-40 to +125	12 [†]	SOT-23	Precision, Micro-Power Shunt Voltage Reference
SGM4051	1.225	Fixed	0.2 [†]			45	20 [†]	-40 to +125	10 [†]	SC70-5	Precision, Micro-Power Shunt Voltage Reference
SGM431	2.5	Adjustable	0.5,1	2.5	36	400	60	-40 to +125	100	SOIC-8,SOT-23,SOT-89-3,SOT-23-5,SC70-6	Adjustable Precision Shunt Regulator
SGM431VB	1.24	Adjustable	0.5	1.24	18	65		-40 to +125	70	SOT-23	Adjustable Precision Shunt Regulator
SGM432	2.5	Adjustable	0.5,1	2.5	36	400	60	-40 to +125	100	SOT-89-3,SOT-23,SOT-23-5	Adjustable Precision Shunt Regulator

Note: † Typical Values @ 25°C

High Performance Video Buffers

The High Performance, High Reliability Video Buffer family provides industry's broadest products of driving Standard Definition and High Definition analog video signals, including 1080p. These comprehensive filtering solutions provide the designers flexibility to easily filter and drive various video signals, including high definition video, DVD and set-top box applications.

1*

Part Number	Standard Definition Channels	High Definition Channels	1080p Support	Shut-down	V _{CC} (V)	Internal Gain (dB)	-3dB Bandwidth Typ (MHz)	-0.1dB Bandwidth Typ (MHz)	Rail-to-Rail Output	Internal Filter	Quiescent Current (mA)	Slew Rate Typ (V/μs)	Group Delay (ns)	Package	Features
SGM9111	1			No	3.0 ~ 5.5	6	8	6	Yes	Yes	6	35	28	SOIC-8,SC70-5	Single Channel, Standard Definition, Small Package
SGM9113	1			No	3.0 ~ 5.5	6	8	6	Yes	Yes	6	35	28	SOIC-8,SC70-5	Single Channel, Standard Definition, Small Package
SGM9114	1			Yes	3.0 ~ 5.5	6	8	6	Yes	Yes	6	35	28	SOT-23-6	Single Channel, Standard Definition, Small Package with Shutdown
SGM9115	3			No	3.3 ~ 5.5	6	9	5.5	Yes	Yes	21	44	31	SOIC-8	Triple Channels, Standard Definition
SGM9116		3		No	3.3 ~ 5.5	6	38.5	30.5	Yes	Yes	30	165	3	SOIC-8	Triple Channels, High Definition, 1080i Supported
SGM9117		3	Yes	No	2.5 ~ 5.5	6	200	92	Yes	No	27.5	300	3	SOIC-8	Triple Channels, High Definition, 1080p Supported
SGM9119	3			No	3.3 ~ 5.5	6	8	5.56	Yes	Yes	21	31.5	31.2	SOIC-8,MSOP-8	Triple Channels, Standard Definition
SGM9121	1			Yes	3.0 ~ 5.5	6	8	6	Yes	Yes	6	35	28	SC70-6	Single Channel, Standard Definition, Small Package with Shutdown
SGM9122	2			No	3.0 ~ 5.5	6	15	8.9	Yes	Yes	5.8			WSOP-8,TSSOP-8	Dual Channels, Standard Definition
SGM9124	4			No	3.3 ~ 5.5	6	8	5.9	Yes	Yes	30	35	28	MSOP-10	Quad Channels, Standard Definition
SGM9125	5			No	3.3 ~ 5.5	6	8	5.8	Yes	Yes	44	35	30.4	TSSOP-14	Five Channels, Standard Definition
SGM9126	6			No	3.3 ~ 5.5	6	8	5.7	Yes	Yes	44	35	30.5	TSSOP-14	Six Channels, Standard Definition
SGM9127	4			No	3.3 ~ 5.5	6	8	5.9	Yes	Yes	30	35	28	TSSOP-14	Quad Channels, Standard Definition
SGM9128YP	1	3		No	3.1 ~ 5.5	6	8.5/46	6.4/32	Yes	Yes	65	34/190	30/2.5	MSOP-10 (Exposed Pad)	Single SD Channel, Triple HD Channels, 1080i Supported, Exposed Pad
SGM9131		3		No	3.1 ~ 5.5	6	46	32	Yes	Yes	55	190	3.5	SOIC-8	Triple Channels, High Definition, 1080i Supported
SGM9132		3	Yes	No	3.1 ~ 5.5	6	98	78	Yes	Yes	75	340	5.3	SOIC-8 (Exposed Pad)	Triple Channels, High Definition, 1080p Supported
SGM9133	1	3	Yes	Yes	3.1 ~ 5.5	6	8.5/46/98	6.4/32/78	Yes	Yes	75	34/190/340	35/3.5/7	TSSOP-14	Single SD Channel, Triple HD Channels, 1080i/1080p Supported with Shutdown
SGM9134	1	3		No	3.1 ~ 5.5	6	8.5/46	6.4/32	Yes	Yes	58	34/190	35/3.5	TSSOP-14	Single SD Channel, Triple HD Channels, 1080i Supported
SGM9135	1	3	Yes	No	3.1 ~ 5.5	6	8.5/98	6.4/78	Yes	Yes	88	34/340	35/5.3	MSOP-10 (Exposed Pad)	Single SD Channel, Triple HD Channels, 1080p Supported
SGM9144	1			Yes	2.5 ~ 4.0	6/12	14/14		Yes	Yes	11.8	60		MSOP-8,TDFN-2x2-8L	Single SD Channel, Capless Output Coupling
SGM9152		1	Yes	Yes	3.1 ~ 5.5	6	79	64	Yes	Yes	15	300	3.5	MSOP-8	Single HD Channel, 1080p Supported
SGM9153		1	Yes	Yes	2.5 ~ 4.0	6	82	62	Yes	Yes	36	305	6.2	MSOP-10,TDFN-3x3-10L	Single HD Channel, 1080p Supported, Capless Output Coupling
SGM9155		1		Yes	3.1 ~ 5.5	6	40		Yes	Yes	12.5	175	3.8	SOT-23-6,SC70-5	Single HD Channel, 720p Supported
SGM9203	3	3	Yes	Yes	3.3 ~ 5.5	6/0	8/18/38/75	5.4/12/30/40	Yes	Yes	40	40/78/155/311	22/13.5/9.5/NA	TSSOP-14	Triple Channels, Selectable SD/PS/HD(1080i)/HD(1080p) with Shutdown
SGM9346	3	3		No	3.3 ~ 5.5	6	8/35	5.36/28.2	Yes	Yes	64.5	39.5/140	10.5/4.9	TSSOP-20	Triple SD Channels, Triple HD Channels

Headphone Drivers

Part Number	Output Power $R_L = 32\Omega$ THD $\leq 0.1\%$, $V_{CC} = 5.0V$	Stereo or Mono	V_{CC} (V)	Differential Input	Shutdown Logic	Shutdown Current		Package	Features
						Typ (μA)	Click-Pop Suppression		
SGM4916	88mW/CH	Stereo	2.7 ~ 5.5	No	Active Low	0.01	Yes	TQFN-3x3-12L	OCL Headphone Driver
SGM4917	80mW/CH	Stereo	2.7 ~ 5.5	Yes	Active Low	0.01	Yes	TQFN-3x3-16L	OCL Headphone Driver with Differential Input
SGM4918	80mW/CH	Stereo	2.7 ~ 5.1	No	Active Low	0.01	Yes	TDFN-3x3-10L	OCL Headphone Driver
SGM8910	55mW/CH	Stereo	2.8 ~ 12	Yes	Active Low	470	Yes	TSSOP-20, TQFN-4x4-20L	Audio Line Driver and Headphone Driver with Click-Pop Noise Cancellation

High Performance Audio Line Drivers

The Audio Line Driver family provides click-pop free stereo line drivers designed to allow the removal of the output DC-blocking capacitors for reduced component count and cost. The products are ideal for single supply electronics where size and cost are critical design parameters. The use of external gain resistors also allows the implementation of a 2nd order low pass filter to complement DAC's and SoC converters.

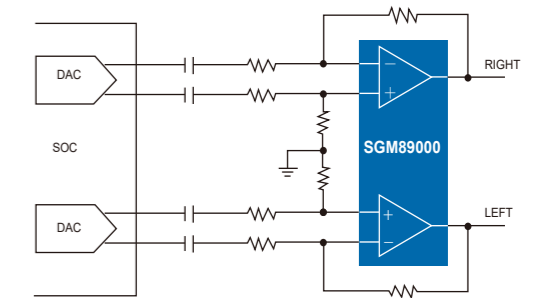

Part Number	Output Voltage $R_L = 2.5k\Omega$ THD = 1%, $V_{CC} = 5.0V$		Stereo or Mono	V_{CC} (V)	Differential Input	Shutdown Logic	Shutdown Current		Click-Pop Suppression	Package	Features
	$R_L = 2.5k\Omega$ THD = 1%, $V_{CC} = 3.3V$	Typ (μA)					Click-Pop Suppression				
SGM8903	3.05Vrms	2.05Vrms	Stereo	3.0 ~ 5.5	Yes	Active Low	130	Yes	TSSOP-14	600 Ω Audio Line Driver with UVP Function	
SGM8904	3.05Vrms	2.05Vrms	Stereo	3.0 ~ 5.5	No	Active Low	130	Yes	MSOP-10	600 Ω Audio Line Driver with UVP Function	
SGM8905	3.05Vrms	2.05Vrms	Stereo	3.0 ~ 5.5	No	Active Low	130	Yes	MSOP-10 (Exposed Pad)	600 Ω Audio Line Driver with UVP Function	
SGM89000		2.05Vrms	Stereo	3.0 ~ 3.6	Yes	Active Low	130	Yes	TSSOP-14	600 Ω Audio Line Driver with UVP Function	

Analog Switches

The Analog Switch family provides industry's broadest analog switches covering the requirements of low on-resistance (as low as 75mΩ), high speed (up to 850MHz), multi-channel selection and high voltage operation (up to 40V).

2*	1*	3*										Package	Features
Channels per Package	Part Number	Type of Switch	V _{CC} (V)	Quiescent Current (μA)	R _{ON} (Ω)	Charge Injection (pC)	Bandwidth @-3dB (MHz)	Digital I/O V _{INH} Min (V)	Digital I/O V _{INL} Max (V)	t _{ON} (ns)	t _{OFF} (ns)		
1	SGM3003	1:2	1.8 ~ 5.5	<1	0.5	5	30	2.4	0.8	21	9	MSOP-8	Small Package, 30MHz, Ultra Low R _{ON} , Single SPDT
1	SGM4157YC	1:2	1.8 ~ 5.5	0.1	0.8		90	1.6	0.4	56	32	SC70-6	Low R _{ON} , Small Package, Single SPDT
1	SGM3798	1:2	2.6 ~ 5.0	2	0.075		100	1.4	0.4	205	210	WLCSP-1.2×1.2-9B,TDFN-3×3-8L	Audio Headset Analog Switch with Reduced GND Switch R _{ON} and FM Capability
1	SGM3001	1:2	1.8 ~ 5.5	<1	2.5	3	120	2.4	0.8	11	30	SC70-6	Small Package, 120MHz, Low R _{ON} , Single SPDT
1	SGM3157	1:2	1.8 ~ 5.5	<5	4.5		300	1.5	0.6	20	15	SC70-6	300MHz, Small Package, Single SPDT
1	SGM3719	1:2	2.5 ~ 5.0	<8	4	16	400	1.65	0.6	15	11	SOT-23-6	400MHz, Negative Signal Passing, Single SPDT
1	SGM3167	1:2	1.8 ~ 5.5	<5	9		600	1.5	0.6	20	15	SC70-6	600MHz, Small Package, Single SPDT
2	SGM4684	1:2	1.8 ~ 5.5	<1	0.4	3	13	2.4	0.8	25	28	WLCSP-2.0×1.5-10B	Ultra Low R _{ON} , Tiny Package, Dual SPDT
2	SGM3005	1:2	1.8 ~ 5.5	<1	0.5	20	15	2.4	0.8	50	15	TDFN-3×3-10L,MSOP-10	Tiny Package, 15MHz, Ultra Low R _{ON} , Dual SPDT
2	SGM2267	1:2	1.8 ~ 4.2	<1	0.4	4	40	1.6	0.5	96	16	TQFN-2.1×1.6-10L	Ultra Low R _{ON} , Tiny Package, Dual SPDT
2	SGM2268	1:2	1.8 ~ 4.2	<1	0.4	4	40	1.6	0.5	88	16	TQFN-1.8×1.4-10L	Ultra Low R _{ON} , Tiny Package, Dual SPDT
2	SGM5223	1:2	1.8 ~ 4.2	<1	0.5	13	55	1.6	0.5	17	27.5	TQFN-1.8×1.4-10L	Ultra Low R _{ON} , Dual, SPDT
2	SGM3718	1:2	2.5 ~ 5.0	<3.5	0.6	85	80	1.5	0.6	17	24	UTQFN-1.8×1.4-10L	80MHz, Negative Signal Passing, Tiny Package, Dual SPDT
2	SGM3712	1:2	2.7 ~ 12	600	0.9	500	100	1.5	0.5	400	100	WLCSP-1.27×2.13-15B,SOIC-14	Excellent THD, Low R _{FLAT(ON)} , Rail-to-Rail Negative Signal Passing
2	SGM3715	1:2	2.7 ~ 12	520	0.8	1000	100	1.5	0.5	880	190	WLCSP-1.27×2.13-15B	Excellent THD, Low R _{FLAT(ON)} , Click-Pop Noise Suppressor, Rail-to-Rail Negative Signal Passing
2	SGM4517	1:2	2.7 ~ 24	350	0.9	500	100	1.5	0.5	400	100	WLCSP-1.27×2.13-15B,SOIC-14	Low R _{FLAT(ON)} , High Off-Isolation, Very Low Crosstalk, Rail-to-Rail Signal Passing
2	SGM3002	1:2	1.8 ~ 5.5	<1	2.5	3	120	2.4	0.8	11	8	MSOP-10	Small Package, 120MHz, Low R _{ON} , Dual SPDT
2	SGM3710	1:2	2.7 ~ 12	300	1/11	600	160/130	1.4	0.4	200	100	TQFN-2.6×1.8-16L,SOIC-16	1Ω/11Ω, High Voltage, Rail-to-Rail Negative Signal Passing
2	SGM4515	1:2	2.7 ~ 24	70	1/11	600	160/130	1.4	0.4	200	60	SOIC-16,TQFN-2.6×1.8-16L	Low R _{FLAT(ON)} , High Off-Isolation, Very Low Crosstalk, Rail-to-Rail Signal Passing
2	SGM3713	1:2	2.7 ~ 9	375	0.18	320	220	1.6	0.4	175	520	TQFN-3×3-16L,WLCSP-1.62×1.23-12B	Excellent THD, Low R _{FLAT(ON)} , Rail-to-Rail Negative Signal Passing
2	SGM3714	1:2	2.7 ~ 9	375	0.18	320	220	1.6	0.4	210ms	720ms	TQFN-3×3-16L,WLCSP-1.62×1.23-12B	Excellent THD, Low R _{FLAT(ON)} , Click-Pop Noise Suppressor, Rail-to-Rail Negative Signal Passing
2	SGM3158	1:2	1.8 ~ 5.5	<5	4.5		270	1.5	0.6	20	15	TDFN-3×1-12L	270MHz, Tiny Package, Dual SPDT
2	SGM2258	1:2	1.8 ~ 5.5	<1	4.5	6	300	1.6	0.5	70	20	TQFN-2.1×1.6-10L	USB2.0 Full Speed Analog Switch
2	SGM2260	1:2	1.8 ~ 4.3	<1	6	10	300	1.6	0.5	20	20	UTQFN-1.8×1.4-10L	6Ω, 300MHz, Low-Power Full-Speed USB (12Mbps) Switch
2	SGM3711	1:2	2.7 ~ 12	300	11	80	300	1.4	0.4	200	60	SOIC-16,TQFN-2.6×1.8-16L	Excellent THD, High Off-Isolation, Very Low Crosstalk, Rail-to-Rail Negative Signal Passing
2	SGM4516	1:2	2.7 ~ 24	70	11	80	300	1.4	0.4	200	60	SOIC-16,TQFN-2.6×1.8-16L	Low R _{FLAT(ON)} , High Off-Isolation, Very Low Crosstalk, Rail-to-Rail Signal Passing
2	SGM4717	1:2	1.8 ~ 5.5	<5	4.5		300	1.5	0.6	26	20	WLCSP-2.0×1.5-10B,MSOP-10,TDFN-3×3-10L,TQFN-1.8×1.4-10L	300MHz, WLCSP, Tiny Package, Dual SPDT
2	SGM3717	1:2	2.5 ~ 5.0	<6	4	16	400	1.5	0.6	15	11	UTQFN-1.8×1.4-10L,MSOP-10	400MHz, Negative Signal Passing, Tiny Package, Dual SPDT
2	SGM7223	1:2	1.8 ~ 4.3	<1	4.5	9.8	500	1.6	0.5	11	20	TQFN-2.1×1.6-10L	USB 2.0 High Speed, Dual SPDT
2	SGM7222	1:2	1.8 ~ 4.3	<1	4.5	11	550	1.6	0.5	10	22	TQFN-1.8×1.4-10L,MSOP-10,UTQFN-1.8×1.4-10L	USB 2.0 High Speed, Dual SPDT
2	SGM7226	1:2	1.8 ~ 5.5	<30	5	10	550	1.5	0.35	15	20	TQFN-2.6×1.8-16L	5.5V, USB 2.0 High Speed, Dual SPDT
2	SGM7227	1:2	1.8 ~ 4.3	<1	5	10	550	1.6	0.5	15	20	MSOP-10,UTQFN-1.8×1.4-10L	550MHz, USB 2.0 Certified, Tiny Package, Dual SPDT
2	SGM7228	1:2	1.8 ~ 4.3	<1	6	11	550	1.6	0.5	10	22	TQFN-1.8×1.4-10L	Low Cost, High Speed USB 2.0 (480Mbps) DPDT
2	SGM7229	1:2	1.8 ~ 5.5	0.1	5.5	2	850	1.5	0.4	40	15	UTQFN-1.8×1.4-10L,MSOP-10	High-Speed USB 2.0 (480Mbps) DPDT

Analog Switches

2 [*]	1 [*]	3 [*]										Package	Features
Channels per Package	Part Number	Type of Switch	V _{CC} (V)	Quiescent Current (μA)	R _{ON} (Ω)	Charge Injection (pC)	Bandwidth @-3dB (MHz)	Digital I/O V _{INH} Min (V)	Digital I/O V _{INL} Max (V)	t _{ON} (ns)	t _{OFF} (ns)		
2	SGM7237B	1:2	2.7 ~ 5.5	26	1.2/4.5			1.7	0.5	0.01ms	300	UTQFN-1.8×1.4-10L,MSOP-10	USB 2.0 + Audio Switch, DPDT
3	SGM4583	1:2	3.6 ~ 11	<20	36	10	140	2.4	0.8	60	70	SSOP-16,TSSOP-16,SOIC-16,TQFN-3×3-16L	High Voltage, Triple 1:2 Mux
3	SGM48753	1:2	2.5 ~ 5.5	<6	48	3	180	1.7	0.5	60	70	SSOP-16,TSSOP-16,SOIC-16,TQFN-3×3-16L	Low R _{ON} , Low Charge Injection, Triple 1:2 Mux
4	SGM3699	1:2	1.8 ~ 4.35	<1	0.5	30	70	1.6	0.5	52	25	TQFN-3×3-16L	70MHz, Low Voltage, Low I _Q , Ultra Low R _{ON} , Quad SPDT
4	SGM3799	1:2	1.8 ~ 4.35	<1	0.5	30	70	1.6	0.5	52	25	TQFN-2.6×1.8-16L	70MHz, Low Voltage, Low I _Q , Ultra Low R _{ON} , Quad SPDT
4	SGM44599	1:2	1.8 ~ 5.5	<1	4	3.5	300	1.6	0.5	31.5	30	TQFN-3×3-16L,TQFN-2.5×2.5-16L	300MHz, Small Package, Quad SPDT
4	SGM44600	1:2	1.8 ~ 5.5	<1	4	4.8	300	1.6	0.5	29.5	29.5	TQFN-3×3-16L	300MHz, Small Package, Quad SPDT
4	SGM44601	1:2	1.8 ~ 5.5	<1	4	3.5	300	1.6	0.5	36	30	TQFN-2.6×1.8-16L	300MHz, Tiny Package, Quad SPDT
4	SGM44602	1:2	1.8 ~ 5.5	<1	4	4.8	300	1.6	0.5	32	26	TQFN-2.6×1.8-16L	300MHz, Tiny Package, Quad SPDT
4	SGM44603	1:2	1.8 ~ 5.5	<1	4.5	20	300	1.6	0.5	40	30	TQFN-2.6×1.8-16L	300MHz, Tiny Package, Quad SPDT
4	SGM5018	1:2	1.8 ~ 5.5	<1	4.5	20	300	1.6	0.5	40	30	TSSOP-16	300MHz, Quad SPDT
4	SGM3700	1:2	2.5 ~ 5.5	<15	4	21	380	1.5	0.5	15	9	TQFN-3×3-16L	380MHz, Negative Signal Passing, Quad SPDT, Tiny Package
4	SGM330A	1:2	2.7 ~ 5.5	<20	12		500	2	0.6	25	13	SOIC-16,TSSOP-16,SSOP-16	Quad, SPDT Video Analog Switch
4	SGM331A	1:2	5	<20	12		500	2	0.6	25	13	SOIC-16,TSSOP-16,SSOP-16	Quad, SPDT Video Analog Switch with 1.2V Self Bias
1	SGM48780	1:4	1.8 ~ 4.2	<1	4	10	150	1.4	0.3	35	9	TDFN-3×3-10L,MSOP-10	Single SPQT
1	SGM48755	1:4	2.5 ~ 5.5	<6	24	3	180	1.7	0.5	50	85	MSOP-10	Low R _{ON} , Low Charge Injection, Single 1:4 Mux
2	SGM4782	1:4	1.8 ~ 4.2	<1	0.5	-18	30	1.6	0.5	20	20	TQFN-3×3-16L,TSSOP-16	Ultra Low R _{ON} , Dual, SPQT
2	SGM4582	1:4	3.6 ~ 11	<20	36	15	120	2.4	0.8	60	60	SSOP-16,TSSOP-16,SOIC-16,TQFN-3×3-16L	High Voltage, Dual 1:4 Mux
2	SGM84782	1:4	1.8 ~ 4.2	<1	4	-18	150	1.6	0.5	17	9	TQFN-3×3-16L,TSSOP-16	Dual SPQT
2	SGM48752	1:4	2.5 ~ 5.5	<6	48	3	180	1.7	0.5	60	70	SSOP-16,TSSOP-16,SOIC-16,TQFN-3×3-16L	Low R _{ON} , Low Charge Injection, Dual 1:4 Mux
2	SGM4589	1:4	4.5 ~ 40		23	18	300	1.6	0.5	50	180	TSSOP-16,SOIC-16	40V, 300MHz, Dual 1:4 Mux in One Package, GPIO Control
1	SGM4581	1:8	3.6 ~ 11	<20	36	15	90	2.4	0.8	60	60	SSOP-16,TSSOP-16,SOIC-16,TQFN-3×3-16L	High Voltage, Single 1:8 Mux
1	SGM4588	1:8	4.5 ~ 40		23	18	160	1.6	0.5	50	180	TSSOP-16,SOIC-16	40V, 160MHz, Single 1:8 Mux in One Package, GPIO Control
1	SGM48751	1:8	2.5 ~ 5.5	<6	48	6	180	1.7	0.5	60	70	SSOP-16,TSSOP-16,SOIC-16,TQFN-3×3-16L	Low R _{ON} , Low Charge Injection, Single 1:8 Mux
4	SGM48754	SPST	2.5 ~ 5.5	<6	24	7	180	1.7	0.5	40	100	TSSOP-14,SOIC-14	Low R _{ON} , Low Charge Injection, Quad SPST
4	SGM4511	SPST	4.5 ~ 40		23	18	300	1.6	0.5	40	120	TSSOP-16,SOIC-16	40V, 300MHz, Quad SPST, Fast Turn-On Time
4	SGM4512	SPST	4.5 ~ 40		23	18	300	1.6	0.5	40	120	TSSOP-16,SOIC-16	40V, 300MHz, Quad SPST, Fast Turn-On Time

Application-Specific Switches

Part Number	Type	V _{CC} (V)	1* Bandwidth @-3dB (MHz)	Control Interface	R _{ON} (Ω)	R _{ON} Flatness (Ω)	C _{ON} (pF)	C _{OFF} C _S /C _D (pF)	Crosstalk Typ (dB)	Charge Injection Typ (pC)	Package	Features
SGM6516	16×8	4.5 ~ 13.2	45	I/O	40		65	25	-47		LQFP-10×10-44L	16×8, Passive
SGM6512	1:16	3.3 ~ 13.2	80	I/O	24	12	75	8/70	-70	25	TQFN-5×5-32L, TSSOP-28	1:16, Multiplexer
SGM6515	1:8	3.3 ~ 13.2	80	I/O	24	12	75	8/70	-70	25	TSSOP-16	1:8, Multiplexer
SGM6501	12×9	3.1 ~ 5.5	84	I ² C					-74		SSOP-28, TSSOP-28	12×9, Buffered
SGM6502	8×6	3.1 ~ 5.5	88	I ² C					-77		TSSOP-24	8×6, Buffered
SGM65232	(1:2)×32	3.3 ~ 5	100	I/O	11		26	13	-60		LQFP-14×14-100L	High Speed, 2:1 32-Bit Bus Multiplexer
SGM6510	16×4	2.7 ~ 5.5	120	I ² C	30	8	40		-110	7	TSSOP-28, TQFN-4×4-28L	16×4, Passive
SGM6511	16×8	2.7 ~ 5.5	120	I ² C	30	8	50		-110	7	TQFN-5×5-32L, LQFP-7×7-32L	16×8, Passive
SGM6513	(1:8)×2	3.3 ~ 13.2	135	I/O	24	12	50	8/36	-70	25	TQFN-5×5-32L, TSSOP-28	Dual 1:8, Multiplexer
SGM6514	16×8	2.7 ~ 5.5	250	I ² C	30	8	50		-110	7	LQFP-7×7-32L	High Speed, 16×8, Passive, I ² C Interface
SGM6518	16×8	2.7 ~ 5.5	250	SPI	28	7	50	25	-55	6	LQFP-7×7-32L	High Speed, 16×8, Passive, Serial Digital Interface
SGM6533	(1:3)×3	2.5 ~ 5.5	350	I/O	7				-60		TQFN-3×3-20L, TSSOP-20	High Speed, 3-1:3 Multiplexer
SGM7232	(1:3)×2	2.7 ~ 4.3	380/400	I/O	4/9		18	7	-90		UTQFN-2.2×1.4-12L	High Speed, 2-1:3 Multiplexer
SGM6503		1.8 ~ 5.5	400	I/O		3.5/0.45	12/185		-80	3/80	TQFN-3×3-20L	SIM I/F Swap
SGM6504	(2:2)×4	1.8 ~ 5.5	400	I/O	12	3.5	12		-80	2.5	TQFN-3×3-20L	4-2:2, Passive Swap
SGM6505	(1:2)×6	2 ~ 5	450	I/O	8.5	4.5	15	4/9	-55	1.2	TSSOP-24, TQFN-4×4-24L	Six Channels 1:2 Multiplexer
SGM65231	SPST	2.3 ~ 3.6	500	I/O	4.5		17.2	13.5			TQFN-4.5×3.5-20L, TSSOP-20	8-Bit, Low Voltage, High Bandwidth Bus Switch
SGM7220	Type C	2.7 ~ 5		I ² C, I/O							UTQFN-1.6×1.6-12L	USB Type-C Configuration, Channel Logic and Port Control

Level Translators

1*												
Translators per Package	Part Number	Data Rate (Mbps)	V _{CC} (V)	V _L Range (V)	V _{CCA} Range (V)	V _{CCB} Range (V)	Bidirectional	V _{CC} Shutdown I/O State	Shutdown I _{CC} Max (μA)	Logic Output	Package	Features
1	SGM4535		2.7 ~ 5.5	1.6 ~ 5.5			Yes	Low			TQFN-5x5-32L	Smart Card Interface
1	SGM4552	24/2			1.65 ~ 5.5	2.3 ~ 5.5	Yes	Hi-Z	5.5	Open-Drain/Push-Pull	UTDFN-1.45x1-6L, SOT-23-6, SC70-6	GPIO Level Shifter
1	SGM4554	100			1.2 ~ 5.0	1.65 ~ 5.5	Yes	Hi-Z	10	Push-Pull	SC70-6, UTDFN-1.45x1-6L	GPIO Level Shifter
1	SGM4555		2.7 ~ 5.5	1.4 ~ 5.5			Yes	Low			TQFN-2x2-12L, TQFN-3x3-16L	Card Interface
1	SGM4560		3.3 ~ 5.5	1.6 ~ 5.5			Yes	Low	8		TSSOP-14	CA Card Interface
1	SGM4561		5.0 ~ 5.5	1.6 ~ 5.5			Yes	Low			MSOP-10	HDMI Interface
2	SGM4551				1.2 ~ 3.3	1.8 ~ 5.5	Yes	Hi-Z	8	Open-Drain	SOT-23-8, XTDFN-1.4x1-8L	I ² C Level Shifter
2	SGM4553	24/2			1.65 ~ 5.5	2.3 ~ 5.5	Yes	Hi-Z	5.5	Open-Drain/Push-Pull	SOT-23-8, XTDFN-1.4x1-8L	GPIO Level Shifter
2	SGM4556	100			1.2 ~ 5.0	1.65 ~ 5.5	Yes	Hi-Z	10	Push-Pull	SOT-23-8, XTDFN-1.4x1-8L	GPIO Level Shifter
2	SGM4558		2.7 ~ 5.5	1.4 ~ 5.5			Yes	Low	2		TQFN-3x3-20L	SIM/Smart Card Interface
4	SGM4563	100			1.2 ~ 5.5	1.65 ~ 5.5	No	Hi-Z	5	Push-Pull	SOIC-14, UTQFN-1.8x1.8-12L	SPI Bus or UART Interface
4	SGM4564	100			1.2 ~ 5.5	1.65 ~ 5.5	Yes	Hi-Z	12/9	Push-Pull	SOIC-14, UTQFN-1.8x1.8-12L, TQFN-2x2-12L	GPIO Level Shifter
4	SGM4574	24/2			1.65 ~ 5.5	2.3 ~ 5.5	Yes	Hi-Z		Open-Drain/Push-Pull	SOIC-14, UTQFN-1.8x1.8-12L, TQFN-2x2-12L	GPIO Level Shifter
4	SGM4T245				1.2 ~ 5.0	1.2 ~ 5.0	Yes	Hi-Z		Push-Pull	TSSOP-16, TQFN-2.6x1.8-16L	4-Bit Non-Inverting Bus Transceiver
6	SGM4566	100			1.2 ~ 5.5	1.65 ~ 5.5	Yes	Hi-Z	12/9	Push-Pull	TSSOP-16, TQFN-2.6x1.8-16L	GPIO Level Shifter
6	SGM4576	24/2			1.65 ~ 5.5	2.3 ~ 5.5	Yes	Hi-Z		Open-Drain/Push-Pull	TQFN-2.6x1.8-16L	GPIO Level Shifter
8	SGM4568	100			1.2 ~ 5.5	1.65 ~ 5.5	Yes	Hi-Z	12/9	Push-Pull	TSSOP-20, TQFN-3x3-20L	GPIO Level Shifter
8	SGM4578	24/2			1.65 ~ 5.5	2.3 ~ 5.5	Yes	Hi-Z		Open-Drain/Push-Pull	TSSOP-20, TQFN-3x3-20L	GPIO Level Shifter
8	SGM8T245				1.2 ~ 5.0	1.2 ~ 5.0	Yes	Hi-Z		Push-Pull	TSSOP-24, TQFN-5.5x3.5-24L	8-Bit Non-Inverting Bus Transceiver

Level Shifters and Drivers

1*											
Channels per Package	Part Number	V _{CC} Range (V)	Logic Low Input Voltage (V)	Logic High Input Voltage (V)	Output Peak Current (A)	Rise Time (ns)	Fall Time (ns)	I _{CC} Typ (mA)	Package	Features	
2	SGM48000	4.5 ~ 26.5	0.7	1.6	2	12	13	1.14	SOIC-8, TDFN-2x2-8L	2A Peak Current, 26.5V, Dual Non-Inverting	
2	SGM48001	4.5 ~ 26.5	0.7	1.6	2	12	13	1.29	SOIC-8, TDFN-2x2-8L	2A Peak Current, 26.5V, Dual Inverting	
2	SGM48002	4.5 ~ 26.5	0.7	1.6	2	12	13	1.19	SOIC-8, TDFN-2x2-8L	2A Peak Current, 26.5V, Inverting and Non-Inverting	

Temperature Sensors

1*

Device Type	Part Number	Interface	V _{CC} (V)	Temp Resolution Max (bits)	Local Sensor Accuracy Max (±°C)	Shutdown Mode Current Max (µA)	Addresses	Supply Current Max (µA)	Operating Temperature Range (°C)	Remote Channels (#)	Package	Features
Local and Remote	SGM451	I ² C and SMBus	3.0 ~ 5.5	12	0°C to +70°C: ±0.5°C -40°C to +125°C: ±1°C	0.5 [†]	8	180 [†]	-40 to +125	1	TDFN-2x2-8BL	±1°C Local and Remote Temperature Sensor with η-Factor and Offset Correction, Series-Resistance Cancellation, and Programmable Digital Filter
Local	SGM452	I ² C	2.7 ~ 5.5	12	-25°C to +100°C: ±1°C -55°C to +125°C: ±2°C	0.5 [†]	8	55 [†]	-55 to +125	0	SOIC-8,MSOP-8	Digital Temperature Sensor and Thermal Watchdog with I ² C Interface

Note: † Typical Values @ 25°C

Supervisory Circuits

The Supervisory Circuits family provides industry standard supervisory IC with high reliability and consistency, featuring low power supply, manual reset, up to 10 reset thresholds suitable for monitoring 1.8V, 2.5V, 3V, 3.3V and 5V supply voltages, adjustable reset time setup with output capacitance and watchdog.

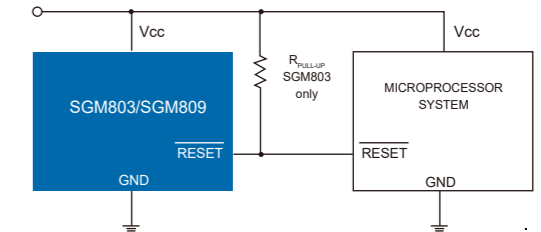

Part Number	Supply Current (µA)	Manual Reset	V _{CC} (V)	Reset Threshold (V)	Watchdog Timer	V _{CC} to Reset Delay (µs)	Reset Active Timeout Period (ms)	Reset Output	Package	Features
SGM706B	0.6	Yes	1.0 ~ 5.5	4.63,4.38,4.0,3.08,2.93,2.63	1.6s		200	Active Low/Push-Pull	UTDFN-1.5×1.5-8L,SOIC-8,MSOP-8	6 Selectable Thresholds, Watchdog, Debounced Manual-Reset Input
SGM708	20	Yes	1.0 ~ 5.5	4.65,4.4,4.0,3.08,2.93,2.63	No		200	Active Low/High/Push-Pull	SOIC-8	6 Selectable Thresholds, Debounced Manual-Reset Input, Dual Reset Outputs
SGM800	3	No	1.0 ~ 5.5	2.93,2.63,2.32,1.63	No	80	Programmable	Active Low/Open-Drain	SOT-23-5	Programmable Reset Timeout, Low Quiescent Current
SGM802	3	No	1.0 ~ 5.5	2.93,2.63,2.32,1.63	No	80	Programmable	Active High/Push-Pull	SC70-4 (R),SOT-143	Programmable Reset Timeout, Low Quiescent Current, Small Package
SGM803B	0.3	No	1.0 ~ 5.5	4.38,4.00,3.08,2.93,2.63	No	110	240	Active Low/Open-Drain	SOT-23-3,SOT-23	5 Selectable Thresholds, Low Power
SGM804	3	No	1.0 ~ 5.5	2.93,2.63,2.32,1.63	No	80	Programmable	Active Low/Push-Pull	SOT-23-5	Programmable Reset Timeout, Low Quiescent Current
SGM809B	0.3	No	1.0 ~ 5.5	4.38,4.00,3.08,2.93,2.63	No	110	240	Active Low/Push-Pull	SOT-23-3,SOT-23	5 Selectable Thresholds, Low Power
SGM810B	0.3	No	1.0 ~ 5.5	4.38,4.00,3.08,2.93,2.63	No	110	240	Active High/Push-Pull	SOT-23-3,SOT-23	5 Selectable Thresholds, Low Power
SGM811B	0.5	Yes	1.0 ~ 5.5	3.08,2.93,2.63	No	100	200	Active Low/Push-Pull	SOT-143	3 Selectable Thresholds, Manual-Reset Input, Low Power
SGM812B	0.5	Yes	1.0 ~ 5.5	3.08,2.93,2.63	No	100	200	Active High/Push-Pull	SOT-143	3 Selectable Thresholds, Manual-Reset Input, Low Power
SGM813B	0.6	No	1.0 ~ 6.0	1.4	No		22	Active Low/Open-Drain	TDFN-2×2-6L	1.4V Fixed Threshold, Low Quiescent Current
SGM820	1.2	Yes	1.6 ~ 6.5	4.8,4.65,3.168,3.069,2.88,2.79,2.4,2.325,1.728,1.674	Programmable	90	200	Active Low/Open-Drain	TDFN-3×3-8L,TDFN-2×2-8L	10 Selectable Thresholds, Watchdog, Manual-Reset Input
SGM822	36	No	2.7 ~ 5.5		No				MSOP-8	The Easiest Method to Sequence Rails, Power-Up and Power-Down Control
SGM823	0.5	Yes	1.0 ~ 5.5	4.63,3.08,2.93,2.63	1.6s	84	200	Active Low/Push-Pull	SOT-23-5	4 Selectable Thresholds, Watchdog, Manual-Reset Input
SGM823A	0.64	Yes	1.0 ~ 5.5	1.67,1.58	1.6s	90	200	Active Low/Push-Pull	SOT-23-5	2 Selectable Thresholds, Watchdog, Manual-Reset Input
SGM824	0.5	No	1.0 ~ 5.5	4.63,3.08,2.93,2.63	1.6s	84	200	Active Low/High/Push-Pull	SOT-23-5	4 Selectable Thresholds, Watchdog
SGM825	0.5	Yes	1.0 ~ 5.5	4.63,3.08,2.93,2.63	No	84	200	Active Low/High/Push-Pull	SOT-23-5	4 Selectable Thresholds, Manual-Reset Input
SGM829	0.6	Yes	1.65 ~ 6.5	1.8 ~ 5	No	80	1.25ms to 10s	Active Low/Open-Drain	SOT-23-5	Adjustable Delay Time, Manual Reset (nMR) Input, Low Quiescent Current
SGM836	0.6	Yes	1.7 ~ 6.5	0.9V ~ 5V/Adjustable voltage down to 0.4V	No	28	1.25ms to 10s	Active Low/Open-Drain	SOT-23-6,TDFN-2×2-6AL	Adjustable Delay Time, Manual Reset (nMR) Input, Low Quiescent Current
SGM890B	0.36	No	1.0 ~ 6.0	0.8 ~ 5	No		Programmable	Active Low/Open-Drain	SOT-23-5	Programmable Reset Timeout, Low Quiescent Current
SGM891B	0.36	No	1.0 ~ 6.0	0.8 ~ 5	No			Active Low/Open-Drain	SOT-23-5	0.8V ~ 5V Selectable Thresholds, Low Quiescent Current
SGM895	2.1	No	1.6 ~ 5.5	Adjustable (0.5V Default)	No		Programmable	Active High/Push-Pull	UTDFN-1.45×1-6AL,TSOT-23-6	Active-High Enable Input Options/Push-Pull Output Options
SGM897	2.1	No	1.6 ~ 5.5	Adjustable (0.5V Default)	No		Programmable	Active High/Open-Drain	UTDFN-1.45×1-6AL,TSOT-23-6	Active-High Enable Input Options/Open-Drain Output Options

Over-Voltage Protection ICs

Part Number	Input Over-Voltage Protection Threshold (V)	Input Voltage Max (V)	Battery Over-Voltage Protection Threshold (V)	Maximum Start-Up Output Current (mA)	Shutdown Current (µA)	Soft-Start	Soft-Stop	LDO Mode Output Voltage (V)	Package	Features
SGM40654	Adj (Default 6.8)	28	NA	4500	<1	Yes	NA	NA	WLCSP-1.30×1.83-12B,TDFN-3×3-12L	120V Surge/Inrush Immunity Function, Adj OVP, 4.5A, Soft Start-Up, 28V Input with Shutdown
SGM40655	Adj (Default 5.81)	28	NA	4500	<1	Yes	NA	NA	WLCSP-1.30×1.83-12B,TDFN-3×3-12L	120V Surge/Inrush Immunity Function, Adj OVP, 4.5A, Soft Start-Up, 28V Input with Shutdown
SGM40659	Adj (Default 15.61)	28	NA	4000	NA	Yes	NA	NA	WLCSP-1.30×0.94-6B	Adj OVP, 4A, 28V Input
SGM40660	Adj (Default 6.8)	28	NA	4000	NA	Yes	NA	NA	WLCSP-1.30×0.94-6B	Adj OVP, 4A, 28V Input

Over-Voltage Protection ICs

Part Number	Input Over-Voltage Protection Threshold (V)	1*		Battery Over-Voltage Protection Threshold (V)	Maximum Start-Up Output Current (mA)	Shutdown Current (μA)	LDO Mode		Package	Features	
		Input Voltage Max (V)	Output Voltage (V)				Soft-Start	Soft-Stop			
SGM40661	Adj (Default 5.94)	28	NA	NA	4000	NA	Yes	NA	NA	WLCSP-1.30×0.94-6B	Adj OVP, 4A, 28V Input
SGM40663	Adj (Default 22.2)	28	NA	NA	4500		Yes	NA	NA	WLCSP-1.17×1.63-12B	110V/-400V Surge/Inrush Immunity Function, Adj OVP, 4.5A, 28mΩ R _{DS(ON)} , Soft Start-Up, 28V Input with Shutdown
SGM40664	Adj (Default 15.3)	28	NA	NA	4500		Yes	NA	NA	WLCSP-1.17×1.63-12B	110V/-400V Surge/Inrush Immunity Function, Adj OVP, 4.5A, 28mΩ R _{DS(ON)} , Soft Start-Up, 28V Input with Shutdown
SGM40665	Adj (Default 10.5)	28	NA	NA	4500		Yes	NA	NA	WLCSP-1.17×1.63-12B	110V/-400V Surge/Inrush Immunity Function, Adj OVP, 4.5A, 28mΩ R _{DS(ON)} , Soft Start-Up, 28V Input with Shutdown
SGM40666	Adj (Default 6.83)	28	NA	NA	4500		Yes	NA	NA	WLCSP-1.17×1.63-12B	110V/-400V Surge/Inrush Immunity Function, Adj OVP, 4.5A, 28mΩ R _{DS(ON)} , Soft Start-Up, 28V Input with Shutdown
SGM40667	Adj (Default 6.35)	28	NA	NA	4500		Yes	NA	NA	WLCSP-1.17×1.63-12B	110V/-400V Surge/Inrush Immunity Function, Adj OVP, 4.5A, 28mΩ R _{DS(ON)} , Soft Start-Up, 28V Input with Shutdown
SGM40668	Adj (Default 5.95)	28	NA	NA	4500		Yes	NA	NA	WLCSP-1.17×1.63-12B	110V/-400V Surge/Inrush Immunity Function, Adj OVP, 4.5A, 28mΩ R _{DS(ON)} , Soft Start-Up, 28V Input with Shutdown
SGM4062	6.8	18	4.35		1500	<2	Yes	Yes	5.1	TDFN-2×2-8L,MSOP-8 (Exposed Pad)	1.5A Fixed Start-Up Current, Soft-Start, Soft-Stop, 18V Input
SGM4064	6.8	18	4.35		Adj (Max 1500)	<2	Yes	Yes	5.1	TDFN-2×2-8L	Adjustable Start-Up Current, Soft-Start, Soft-Stop, 18V Input

Li-Ion Battery Chargers and Protection ICs

1* Part Number	Input Over-Voltage Protection Threshold (V)	Charge Voltage (V)	V _{IN} Min (V)	V _{IN} Max (V)	Programmable Current (mA)	Shutdown Current		Foldback Current From Battery (μA)	Package	Features
						From V _{IN} (μA)	Status Indication			
SGM4056	6.8,10.5	4.2	4.55	26.5	100 ~ 900	200	Yes	<1	TDFN-3×3-8L,TDFN-2×3-8L,TDFN-2×2-8L,SOIC-8 (Exposed Pad)	100mA ~ 900mA, 6.8V/10.5V Over-Voltage Protection, Input Voltage up to 26.5V
SGM40560		3.65,4.05,4.2,4.3,4.4	2.7	7.5	5 ~ 700	7.5	Yes	<1	TDFN-2×2-6AL,SOIC-8 (Exposed Pad)	Small Capacity Compact Battery Charger for Loosely Coupled Wireless Charging or Solar Charging
SGM40561	10.5	4.2,4.3,4.35	4.55	26.5	5 ~ 200	180	Yes	<1	TDFN-2×2-8L	5mA ~ 200mA, 10.5V Over-Voltage Protection, Input Voltage up to 26.5V
SGM40565		4.2,4.35	4.55	26.5	5 ~ 400	175	Yes	<1	XTDFN-2×2-8L,TDFN-2×2-8L,WLCSP-1.3×0.7-6B	Ultra-Thin Package, 5mA ~ 400mA, 4.2V/4.35V Output Voltage for Long Battery Life Application
SGM41002	4.35, 4.45,4.5		3.6	24		<3	No		UTDFN-2×2.5-8L	Battery Protection IC for 2-Serial to 4-Serial-Cell Pack (Secondary Protection)
SGM41100	4.2,4.25,4.3,4.35,4.4,4.45,4.5,4.55		0	6		<0.1	No		UTDFN-1.5×2-6L	Single Battery Protection IC
SGM41101	4.2,4.25,4.3,4.35,4.4,4.45,4.5,4.55		0	6		<0.1	No		TDFN-2×2-6L	Single Battery Protection IC
SGM41510	Adj (Default 15.1)	3.84 ~ 4.608	3.9	14	0 ~ 5120	50	Yes	21	TQFN-4×4-24L	I ² C Controlled 5A Single-Cell Battery Charger with Power Path Management
SGM41511	6.5,10.5,14	3.856 ~ 4.624	3.9	13.5	0 ~ 3000	45	Yes	20	TQFN-4×4-24L	I ² C Controlled 3A Single-Cell Battery Charger with Power Path Management
SGM41512	6.5,10.5,14	3.848 ~ 4.616	3.9	13.5	0 ~ 3000	45	Yes	20	TQFN-4×4-24L	I ² C Controlled 3A Single-Cell Battery Charger with Power Path Management
SGM41524	5.67	4.2 ~ 4.5	3.5	5.5	300 ~ 2300	15	Yes	<1.4	TDFN-2×3-8BL	Compact Switch Li+/Poly Battery Charger Safe and Reliable Charging
SGM41526	Adj	8.4/12.6/16.8	4.5	22	0 ~ 4000	1300	Yes	18	TQFN-5.5×3.5-24L	2-4 Cells Stand-Alone Battery Charger with Integrated MOSFETs and Power Path Selector
SGM41527	Adj	Adj	4.5	22	0 ~ 4000	1300	Yes	18	TQFN-5.5×3.5-24L	1-4 Cells Stand-Alone Battery Charger with Integrated MOSFETs and Power Path Selector
SGM41562	6.02	3.6 ~ 4.545	4.35	5.5	8 ~ 456		Yes	<1	WLCSP-1.47×1.47-9B	500mA Single Cell Li-Ion Battery Charger with Power Path Management

DC/DC Converters

The DC/DC Converter family provides various DC/DC converters with high efficiency, high reliability in six different topologies, featuring high input voltage, low shutdown current, tiny DFN package, and SOIC-8 with exposed pad. All these features make the family extremely suitable for portable and industrial applications.

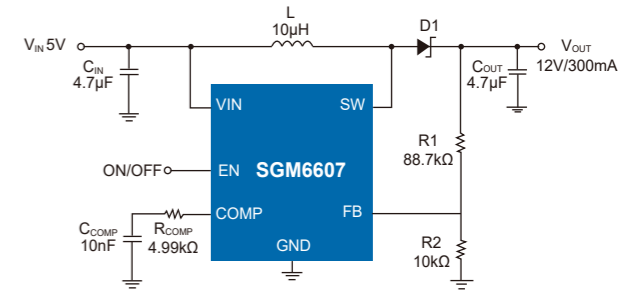

DC/DC Topology	Part Number	Output Current Max (mA)	VIN (V)		Output Voltage (V)	Switching Frequency (MHz)	Quiescent Current (µA)	Shutdown Current (µA)	Enable Logic	Efficiency Max	Package	Features
			Min	Max								
AMOLED Display Power Supply	SGM38042	40	2.7	5.5	1.8 or 2.8/Adj (-2.4 ~ -6.4)/Adj (2.4 ~ 6.4)	1.6	500	<1	Active High	87%	WLCSP-1.51×2.10-15B	P/N Voltage Output, 40mA Output Current Synchronous Boost with a 50mA LDO
AMOLED Display Power Supply	SGM3833A	400	2.9	4.5	Adj (5.8 ~ 7.9)/Adj (4.6 ~ 5.0)/Adj (-4.8 ~ -0.8)	1.5		<1	Active High	92%	TQFN-3×3-16L	Triple-Output, Synchronous Boost, Synchronous Inverting Buck-Boost
AMOLED Display Power Supply	SGM3833B	400	2.9	4.5	Adj (5.8 ~ 7.9)/Adj (4.6 ~ 5.0)/Adj (-5.4 ~ -1.4)	1.5		<1	Active High	92%	TQFN-3×3-16L	Triple-Output, Synchronous Boost, Synchronous Inverting Buck-Boost
AMOLED Display Power Supply	SGM3851A	400	2.9	4.5	Adj (5.8 ~ 7.9)/Adj (4.6 ~ 5.0)/Adj (-5.4 ~ -1.4)	1.5		<1	Active High	92%	TQFN-3×3-16L	Triple-Output, Synchronous Boost, Synchronous Inverting Buck-Boost
AMOLED Display Power Supply	SGM3838	700	2.5	4.8	Adj (5.5 ~ 7.9)/Adj (4.6 ~ 5.0)/Adj (-6.0 ~ -0.8)	1.45		<1	Active High	93%	WLCSP-2.5×2.5-36B	Triple-Output, Synchronous Boost, Synchronous Inverting Buck-Boost
LCM Bias Power Supply	SGM3804	100	2.7	5.5	Adj (2.4 ~ 6.4)	1.6	400	<1	Active High	84%	WLCSP-1.7×1.51-12B	P/N Voltage Output, 100mA Output Current Synchronous Boost
LCM Bias Power Supply	SGM3803	200	2.7	5.5	Adj (up to 5.2)	1.2/0.95	30	<1	Active High	90%	TDFN-3×3-12L	P/N Voltage Output, 200mA Output Current Synchronous Boost
Non-Sync Boost	SGM6607	300†	3	20	Adj (up to 38)	1.2	400	<1	Active High	93%	TDFN-2×2-6L, TSOT-23-6	1.1A Switch, Internal MOSFET, High Voltage Non-Synchronous Boost
Non-Sync Boost	SGM6623	4400	0.8	12	Adj (3.3 ~ 13)	0.6	47	<1	Active High	90%	SOT-23-6	4.4A, Miniature Boost Converter
Non-Sync Boost	SGM41286	500 (TYP)	7	14	14/19	0.022/1.41	60	<5.5	Active High	90%	TDFN-3×3-8L, SOIC-8 (Exposed Pad)	LNB Supply with Tone Repeater/Synthesizer and Programmable Cable Drop Compensation
Non-Sync Boost	SGM6601		1.8	5.5	Adj (up to 38)	up to 1	20	<1	Active High	85%	TSOT-23-5, TDFN-2×2-6L	400mA Switch, Internal MOSFET, High Voltage Non-Synchronous Boost
Non-Sync Buck	SGM6061	1500	3.8	55	Adj (0.8 ~ 24)	2	120	<20	Active High	95%	TDFN-3×3-10L	1.5A, 2MHz, 55V, Buck Converter
Non-Sync Buck	SGM6060	2000	3.8	55	Adj (0.8 ~ 24)	2	120	<20	Active High	95%	TDFN-3×3-10L, SOIC-8 (Exposed Pad)	2A, 2MHz, 55V, Buck Converter
Sync Boost	SGM66099B	300	1.2	5.2	5.0/Adj (2.5 ~ 5.2)	1.2	1.75	<1	Active High	93%	WLCSP-1.22×0.83-6B, TDFN-2×2-6AL	Synchronous Boost Converter with Ultra Low Quiescent Current
Sync Boost	SGM6603	600	0.9	5.5	3.3/5.0/Adj	1.2	30	<1	Active High	90%	SOT-23-6	0.9V Input, Synchronous Boost
Sync Boost	SGM6602	900	1.8	5.5	Adj (4.5 ~ 20)	1.1	41	<1	Active High	85%	WLCSP-0.8×1.2-6B, TDFN-2×2-6L	20V Output, Synchronous Boost
Sync Boost	SGM41280	3000	2.2	4.9	3.35/3.45/3.63/3.85/4.25	2.5	10	0.6	Active High	95%	WLCSP-1.27×1.67-12B, TQFN-3×3-16L	Low Voltage, Wide Input Range, Front-End DC/DC
Sync Boost	SGM6611C	7000	2.7	12	Adj (4.5 ~ 12.6)	1.1	90	0.6	Active High	90%	TQFN-2×2.5-11L	7A Fully-Integrated, Synchronous Boost
Sync Boost	SGM6610	10000	2.7	12	Adj (4.5 ~ 12.6)	0.5	80	0.5	Active High	91%	TQFN-4.5×3.5-20L	10A Fully-Integrated, Synchronous Boost
Sync Boost	SGM6612A	10000	2.7	16	Adj (4.5 ~ 20)	2.2	130	3.7	Active High	95%	TQFN-3×3.5-13L	10A Fully-Integrated Synchronous Boost
Sync Buck	SGM6021	200	1.8	5.5	Adj	1.4	0.4	<1	Active High	90%	UTDFN-1.5×2-6L	1.4MHz, 200mA Synchronous Buck
Sync Buck	SGM6031	200	1.8	5.5	1.0/1.2/1.5/1.8/2.5/2.8/3.0/3.3/Adj	1.4	0.4	<1	Active High	90%	UTDFN-1.5×2-6L, WLCSP-0.90×0.88-5B	1.4MHz, 200mA Synchronous Buck
Sync Buck	SGM6022	600	2.5	5.5	Adj	6	22	<1	Active High	90%	TDFN-2×2-6L	6MHz, 600mA Synchronous Buck
Sync Buck	SGM6032	600	2.5	5.5	0.6/0.8/1.0/1.1/1.15/1.2/1.5/1.6/1.8/2.5/2.8/3.0/3.3	6	22	<1	Active High	90%	TDFN-2×2-6L, WLCSP-1.21×0.81-6B	6MHz, 600mA Synchronous Buck
Sync Buck	SGM6036	600	1.8	5.5	1.0/1.2/1.5/1.8V/2.5/2.8/3.0/3.3/Adj (1 to 3.3)	1.4	0.45		Active High	90%	UTDFN-1.5×2-6L	Ultra Low Power Buck Converters with up to 600mA Output Current
Sync Buck	SGM61410	600	5	45	Adj	1.2	14	<1.2	Active High	95%	SOT-23-6	1.2MHz, 600mA, 45V, Synchronous Buck
Sync Buck	SGM6033	1000	2.5	5.5	Adj	4.6	26	<1	Active High	90%	TDFN-2×2-6L, WLCSP-1.21×0.81-6B	4.6MHz, 1A Synchronous Buck
Sync Buck	SGM61010	1000	2.5	5.5	Adj (0.6 ~ VIN)	1.5	40	<2	Active High	95%	SOT-23-5, SOT-23-6, TDFN-2×2-6AL	1A High Efficiency Synchronous Buck
Sync Buck	SGM61020	2000	2.5	5.5	Adj (0.6 ~ VIN)	1.5	40	<2	Active High	95%	SOT-23-5, SOT-23-6, TDFN-2×2-6AL	2A High Efficiency Synchronous Buck
Sync Buck	SGM61220	2000	4.5	28	Adj	0.4	30	3	Active High	95%	TSOT-23-6	2A, High Efficiency, 28V Voltage, Synchronous Buck
Sync Buck	SGM61133	3000	4.5	17	Adj	0.7	200	7	Active High	95%	SOT-563-6	3A, High Efficiency, 17V Voltage, Synchronous Buck
Sync Buck	SGM61133A	3000	4.5	17	Adj (0.6 ~ 12)	0.7	200	7	Active High	93%	SOT-23-6	3A Switch, Internal MOSFET, High Efficiency, Synchronous Buck
Sync Buck	SGM61230	3000	4.5	28	Adj	0.4	30	3	Active High	95%	TSOT-23-6	3A, High Efficiency, 28V Voltage, Synchronous Buck

Note: † Input Voltage = 5V, Output Voltage = 12V

DC/DC Converters

DC/DC Topology	Part Number	Output Current Max (mA)	V _{IN}		Output Voltage (V)	Switching Frequency (MHz)	Quiescent Current (μA)	Shutdown Current (μA)	Enable Logic	Efficiency Max	Package	Features
			Min (V)	Max (V)								
Sync Buck	SGM61430	3000	4.5	36	Adj (0.8 ~ 24)	0.2 to 2	60	<4	Active High	95%	SOIC-8 (Exposed Pad)	36V, 3A, Synchronous Buck
Sync Buck	SGM61160A	6000	4.5	18	Adj (0.76 ~ 5.5)	0.65	400	<15	Active High	96%	SOIC-8 (Exposed Pad)	4.5V to 18V Input, 6A, Synchronous, Buck Converter with Power-Save Mode
Sync Buck	SGM61160B	6000	4.5	18	Adj (0.6 ~ 5.5)	0.42	400	<15	Active High	96%	SOIC-8 (Exposed Pad)	4.5V to 18V Input, 6A, Synchronous, Buck Converter with Power-Save Mode
Sync Buck	SGM61163	6000	4.5	18	Adj	0.2 to 2	1100	<5	Active High	95%	TQFN-3.5×3.5-14L	4.5V to 18V Input, 6A, Synchronous Buck
Sync Buck	SGM61164	6000	4.5	18	Adj	0.2 to 2	1100	<5	Active High	95%	TQFN-3.5×3.5-14L	4.5V to 18V Input, 6A, Synchronous Buck

Charge Pump DC/DC Converters

Converters per Package	Part Number	Output Current Max (mA)	Shutdown	V _{IN}		Output Voltage (V)	Switching Frequency (kHz)	Quiescent Current (μA)	Shutdown Current (μA)	Output Type	Package	Features
				Min (V)	Max (V)							
2	SGM3200	500	Yes	2.7	5	5	1700	70	<2	Regulated	TDFN-3×3-8L	Low Noise, Doubler/White LED Driver
1	SGM3204	200	Yes	1.4	5.5	-V _{IN}	950	1500	<1	Unregulated	SOT-23-6	Unregulated Inverter, 950kHz, 200mA
1	SGM3110	100	Yes	2.7	5	5	750	60	<1	Regulated	SOT-23-6	Low Noise, Doubler/White LED Driver
1	SGM3209	100	Yes	3	18	-V _{IN}	120 ~ 1250	900	<1.2	Unregulated	SOIC-8, TDFN-2×2-8L	Unregulated Inverter, Programmable Frequency, 100mA
1	SGM3206	60	No	1.4	5.5	-V _{IN}	47	115	NA	Unregulated	SOT-23-5	Unregulated Inverter, 47kHz, 60mA

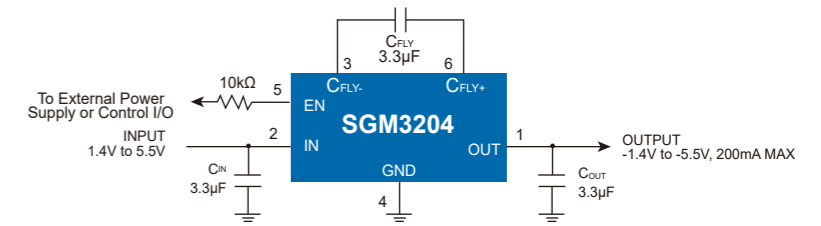

High Reliability LDOs

Part Number	V _{IN} Min (V)	V _{IN} Max (V)	Output Current (mA)	Dropout Voltage (mV)	Ground Current (No Load) (μA)	PSRR @1kHz (dB)	V _{OUT} (V)	Package	Features
SGM2225	3.6	36	800	480	75	75	3.3,5.0,12,Adj	TDFN-3×3-8L,SOIC-8,SOT-89-3,SOT-223-3,TO-263-5B	High Voltage, Low Noise
SGM2208	2.7	24	3000	155		55	Adj	TDFN-3×3-12L,TO-263-5B	High Voltage, Low Noise, Current Source Reference
SGM2205	2.5	20	800	480	80	75	1.8,2.5,3.0,3.3,3.6,4.2,5.0,12,Adj	TDFN-3×3-8L,SOIC-8,SOT-89-3,SOT-223-3,TO-263-5B	High Voltage, Low Noise
SGM2207	2.5	20	800	450	2.7	75	Adj	TDFN-2×3-8BL	High Voltage, Low Noise
SGM2212	2.7	20	800	280	80	75	1.8,2.5,2.8,3.3,5.0,Adj	TDFN-3×3-8L,SOT-223-3,TO-263-3,TO-252-2	High Voltage, Low Noise
SGM2211	2.7	20	500	360	39	100	1.2,1.5,1.8,2.5,2.8,3.0,3.3,3.8,4.2,5.0,Adj	TDFN-2×2-6AL,SOT-23-5	High Voltage, Low Noise
SGM2210	2.5	20	300	240	36	100	1.2,1.8,2.5,3.3,5.0,Adj	SOT-23-5	High Voltage, Low Noise
SGM2214	2.7	16	300	270	32	85	3.3	SOIC-8	High Voltage, Low I _Q , Low Dropout
SGM2209	-2.7	-24	-500	-260	-42	-71	1.2,1.5,1.8,2.5,2.8,3.0,3.3,5.0,Adj	TDFN-2×2-6AL,TDFN-3×3-8L,SOT-23-5	High Voltage, Low Noise, High PSRR

High Accuracy, Low Noise, Low Power LDOs

Part Number	V _{OUT} (V)	V _{IN} (V)	Output Current (mA)	Dropout Voltage (mV)	Ground Current (No Load) (μA)	Output Voltage Noise (μV _{RMS})	PSRR @1kHz (dB)	Package	Features
SGM2018	1.8,2.8,3.0,3.3	1.7 ~ 5	250	70 @100mA	1		27	SOT-23-5,UTDFN-1×1-4AL	Ultra Low Current Consumption, Low Dropout
SGM2033	1.2,1.8,2.5,2.8,2.85,2.9,2.95,3.0,3.3,3.4,2.5,0,Adj	1.8 ~ 5.5	250	62	13.5	20	94	SOT-23-5,UTDFN-1×1-4AL	Ultra Low Noise, High PSRR
SGM2034	1.2,1.8,2.5,2.8,3.0,3.3,3.6,3.8,4.0,4.5,5.0	1.7 ~ 7.5	250	75 @100mA	1		27	SOT-23-3,SOT-89-3	Ultra Low Current Consumption, Low Dropout
SGM2037	0.8,0.9,1.0,1.05,1.1,1.15,1.2,1.25,1.3,1.5,1.8,2.5,2.8,3.0,3.3,3.6,Adj	0.8 ~ 5.5	500	120	37	25	71	SOT-23-5,SOT-23-6,UTDFN-1.2×1.2-6L	Low Noise, Very Low Dropout
SGM2038	0.8,0.9,1.0,1.05,1.1,1.15,1.2,1.25,1.3,1.5,1.8,2.5,2.8,3.0,3.3,3.6	0.8 ~ 5.5	500	120	37	25	71	UTDFN-1.2×1.2-4L	Low Noise, Very Low Dropout
SGM2040	1.2,1.5,1.8,2.5,2.8,3.0,3.3,3.6,4.0,4.2,5.0	1.7 ~ 7.5	250	60 @100mA	1		27	SOT-23-5,UTDFN-1×1-4AL	Ultra Low Current Consumption, Low Dropout
SGM2041	1.2,1.5,1.8,2.5,2.8,3.0,3.3,3.6,4.2	1.8 ~ 5.5	250	88	13.5	20	94	WLCSP-0.67×0.67-4B	Ultra Low Noise, Small Package, Low Dropout

Load Switches

Load switches are integrated electronic relays used for turning on and off power rails, power distribution and power savings. Load switches can be used in telecommunication equipment, computer equipment & peripherals, TVs & STBs, small portable devices, and test equipments with the benefits of reducing overall BOM count and solution size, as well as adding additional protection features.

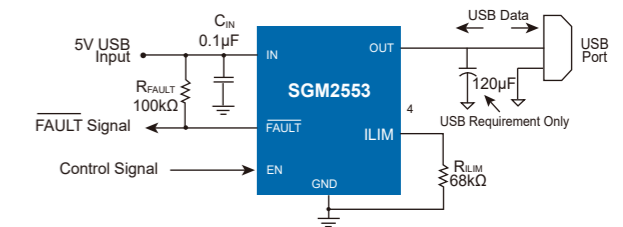

Switches per Package	Part Number	Continuous Output Current (mA)	Quiescent Current (μA)	V _{IN} Min (V)	V _{IN} Max (V)	Enable Logic	Shutdown Current (μA)	Current Limit (mA)	Soft-Start	Fault Flag	Package	Features
1	SGM2571	1000	0.22	1	5.5	Active High	<0.44		Yes	No	WLCSP-0.8×0.8-4B	1A, Ultra Low Quiescent Current, WLCSP Package
1	SGM2574	1000	0.22	1	5.5	Active High	<0.44		Yes	No	WLCSP-0.8×0.8-4B	1A, Ultra Low Quiescent Current, WLCSP Package
1	SGM2578	1000	5	1.0	5.0	Active High	<1.5	1600	Yes	No	WLCSP-0.9×0.9-4B	1A, Ultra Low Quiescent Current, WLCSP Package
1	SGM2581A	1000	23	3	5.5	Active High	<1	1100	Yes	Yes	SOT-23-5	1A Output Current, 1.1A Fixed Current Limit, Low Power, Auto Discharge
1	SGM2588A	1000	23	3	5.5	Active High	<1	1100	Yes	Yes	SOT-23-5	1A Output Current, 1.1A Fixed Current Limit, Low Power, Auto Discharge
1	SGM2588G	1000	23	3	5.5	Active High	<1	1100	Yes	Yes	SOT-23-5	1A Output Current, 1.1A Fixed Current Limit, Low Power, Default Disable /EN
1	SGM2554A	1100	19	2	5.5	Active High	<1	1850	Yes	No	SOT-23-5	1.1A Output Current, 1.85A Fixed Current Limit, Low Power
1	SGM2554B	1100	19	2	5.5	None	NA	1750	Yes	No	SOT-23-5	1.1A Output Current, 1.75A Fixed Current Limit, Low Power
1	SGM2555	1100	19	2	5.5	Active High	<1	1850	Yes	No	TDFN-2×2-6L	1.1A Output Current, 1.85A Fixed Current Limit, Low Power
1	SGM2523A	1200	160	3	24	Active High	0.8	Programmable (100~1200)	Yes	Yes	SOT-23-6	24V, 1.2A, Auto-Recovery Programmable Current Limit Switch
1	SGM2523B	1200	160	3	24	Active High	0.8	Programmable (100~1200)	Yes	Yes	SOT-23-6	24V, 1.2A, Latched-Off Programmable Current Limit Switch
1	SGM2551A/C	1500	71	3	5.5	Active High	<2.5	Programmable (100~1700)	Yes	No	TDFN-2×2-6L,SOT-23-5	1.5A, Adjustable Current Limit, Soft-Start, Tiny Package
1	SGM2553/D	1500	71	3	5.5	Active High	<2.5	Programmable (100~1700)	Yes	Yes	TDFN-2×2-6L,SOT-23-6	1.5A, Adjustable Current Limit, Soft-Start, Tiny Package
1	SGM2521	2000	170	5	24	Active High	<1.4	Programmable (260~2000)	Yes	Yes	SOIC-8,TDFN-2×3-8BL	24V, 2A, Auto-Recovery Programmable Current Limit Switch
1	SGM2522	2000	170	5	24	Active High	<1.4	Programmable (260~2000)	Yes	Yes	SOIC-8,TDFN-2×3-8BL	24V, 2A, Latched-Off Programmable Current Limit Switch
1	SGM2572	2000	0.22	1	5.5	Active High	<0.44		Yes	No	WLCSP-0.8×0.8-4B	2A, Ultra Low Quiescent Current, WLCSP Package
1	SGM2575	2000	0.22	1	5.5	Active High	<0.44		Yes	No	WLCSP-0.8×0.8-4B	2A, Ultra Low Quiescent Current, WLCSP Package
1	SGM2578A	2000	0.22	1.0	5.5	Active High	< 0.65		Yes	No	WLCSP-0.9×0.9-4B-A	2A, Ultra Low Quiescent Current, WLCSP Package

Load Switches

1 [†] Switches per Package	Part Number	2 [†] Continuous Output Current (mA)	Quiescent Current (μA)	V _{IN}	V _{IN}	Enable Logic	Shutdown Current (μA)	Current Limit (mA)	Soft- Start	Fault Flag	Package	Features
				Min (V)	Max (V)							
1	SGM2581C	2000	23	3	5.5	Active High	<1	2100	Yes	Yes	SOT-23-5	2A Output Current, 2.1A Fixed Current Limit, Low Power, Auto Discharge
1	SGM2588C	2000	23	3	5.5	Active High	<1	2100	Yes	Yes	SOT-23-5	2A Output Current, 2.1A Fixed Current Limit, Low Power, Auto Discharge
1	SGM2588I	2000	23	3	5.5	Active High	<1	2100	Yes	Yes	SOT-23-5	2A Output Current, 2.1A Fixed Current Limit, Low Power, Default Disable /EN
1	SGM2581E	2500	23	3	5.5	Active High	<1	2600	Yes	Yes	SOT-23-5	2.5A [†] Output Current, 2.6A Fixed Current Limit, Low Power, Auto Discharge
1	SGM2588E	2500	23	3	5.5	Active High	<1	2600	Yes	Yes	SOT-23-5	2.5A [†] Output Current, 2.6A Fixed Current Limit, Low Power, Auto Discharge
1	SGM2588K	2500	23	3	5.5	Active High	<1	2600	Yes	Yes	SOT-23-5	2.5A [†] Output Current, 2.6A Fixed Current Limit, Low Power, Default Disable /EN
1	SGM2564	4000	0.44	1	5.5	Active High	<0.55		Yes	No	WLCSP-1.45×0.95-6B	4A, Ultra Low Quiescent Current, WLCSP Package
1	SGM2525	5000	170	5	22	Active High	<1.2	Programmable (1000~5000)	Yes	Yes	TDFN-3×3-10L	Programmable Current Limit Switch with Output Voltage Protection
1	SGM2526	5000	170	5	22	Active High	<1.2	Programmable (1000~5000)	Yes	Yes	TDFN-3×3-10L	Programmable Current Limit Switch with Output Voltage Protection
1	SGM2541	±5000	123	3	20	Active Low			Yes	Yes	WLCSP-2.43×1.75-20B	28V/16V Bidirectional Load Switch with Wireless/Dual Input Capability
1	SGM4075-2	6000	1	1.5	5.5	None	<1.5		Yes	No	WLCSP-1.31×1.62-12B	6A, Reset Timer with Integrated Load Switch, WLCSP Package
1	SGM2566A	6000	16	1	5.3	Active High	<1.4		Yes	Yes	TDFN-2×2-8L	6A, 17mΩ On-Resistance Load Switch
1	SGM2566B	6000	16	1	5.3	Active High	<1.4		Yes	Yes	TDFN-2×2-8L	6A, 17mΩ On-Resistance Load Switch
1	SGM4073	6000	1	1.5	5.5	None	<1.5		Yes	No	WLCSP-1.31×1.62-12B	6A, Ultra Low Quiescent Current, Programmable Reset Timer, WLCSP Package
1	SGM4075-1	6000/4500	1	1.5	5.5	None	<1.5		Yes	No	WLCSP-1.31×1.62-12B,TDFN-3×3-8L	6A/4.5A, Reset Timer with Integrated Load Switch, WLCSP/TDFN Packages
1	SGM4076	6000/4500	1	1.6	5.5	None	<1.5		Yes	No	WLCSP-1.31×1.62-12B,TDFN-3×3-8L	6A/4.5A, Reset Timer with Integrated Load Switch, WLCSP/TDFN Packages
1	SGM2576/B	Adj	23	3	5.5	Active High	<1	Programmable (100~2500)	Yes	No	SOT-23-5	Adjustable Current Limit, Soft-Start, Low Power
2	SGM2558A	600/CH	28	3	5.5	Active High	<1	1100	Yes	Yes	SOIC-8,TDFN-3×3-8L	600mA Output Current, 1.1A Fixed Current Limit, Dual Channels
2	SGM2558B	600/CH	28	3	5.5	Active Low	<1	1100	Yes	Yes	SOIC-8,TDFN-3×3-8L	600mA Output Current, 1.1A Fixed Current Limit, Dual Channels
2	SGM2560A	600/CH	28	3	5.5	Active High	<1	1100	Yes	Yes	SOIC-8,TDFN-3×3-8L	600mA Output Current, 1.1A Fixed Current Limit, Dual Channels
2	SGM2560B	600/CH	28	3	5.5	Active Low	<1	1100	Yes	Yes	SOIC-8,TDFN-3×3-8L	600mA Output Current, 1.1A Fixed Current Limit, Dual Channels
2	SGM2540	2000/1500	88	3	20	None			Yes	No	UTDFN-2×2-8AL	Autonomous 20V Charging Sources Selection and OTG Feeding Switch Combo

Note: † This parameter is guaranteed by design and characterization.

Flash LED Driver

Channels per Package	1 [†] Part Number	Output Current per Channel (mA)	V _{IN}	V _{IN}	Shutdown Current (μA)	Switching Frequency (MHz)	Quiescent Current (mA)	Package	Features
			Min (V)	Max (V)					
2	SGM3785	750	3	5	<1	2	0.45	TDFN-3×2-14L	Flash Dimming Function

White LED Drivers

The White LED Driver family offers various solutions for LCD backlighting in portable device applications. The devices operate from 2.5V to 24V input supply range and deliver an output voltage up to 38V with up to 8 channels in parallel and up to 10 LEDs in series.

Channels per Package	Part Number	V _{IN} Min (V)	V _{IN} Max (V)	LEDs per String	Shutdown Current (μA)	Switching Frequency (MHz)	LED Connection Type	Quiescent Current (mA)	Dimming Method	Package	Features
1 [†]	SGM3110	2.7	5	1	<1	0.75	Common Anode	0.06	PWM	SOT-23-6	1P Charge Pump LED Driver
1	SGM3752	2.7	5.5	10	<1	1.2	Common Anode	0.2	PWM	TSOT-23-6	1:250 High Performance, 10 LEDs per String
1	SGM3756	2.7	5.5	10	<1	1.2	Common Anode	0.2	PWM	TDFN-2×2-6L	1:250 High Performance, 10 LEDs per String
1	SGM3758	2.7	5.5	7	<1	1.2	Common Anode	0.2	PWM	TDFN-2×2-6L	1:500 High Performance, Screen Flash Mode Support
1	SGM3759	2.7	5.5	7	<1	1.2	Common Anode	0.2	PWM	TSOT-23-6	1:500 High Performance, Screen Flash Mode Support
1	SGM3766	2.7	5.5	10	<1	1.2	Common Anode	0.2	PWM	TSOT-23-5	1:500 High Performance, 10 LEDs per String
2	SGM3743	3	18	10	<1	1.2	Common Anode	1.2	PWM & One-Wire	WLCSP-1.32×1.32-9B	2 Feedback Channels, 18V Input, Serial LED Driver
2	SGM3760	2.7	5.5	10	<1	1.15	Common Anode	1.7	PWM	WLCSP-1.32×1.32-9B	2 Feedback Channels, Serial LED Driver
3	SGM31323	2.5	5.5	1	<1		Common Anode	0.041	I ² C	UTDFN-1.5×1.5-8L	I ² C Programmable RGB LED Driver
3	SGM31324	2.5	5.5	1	<1		Common Anode	0.041	I ² C	UTDFN-1.5×1.5-8L	I ² C Programmable RGB LED Driver with Auto Blink Mode
3	SGM3741	3	18	10	<1	0.6	Common Anode	0.24	PWM & PWM	TQFN-3×3-16L	3 Feedback Channels, 18V Input, Serial LED Driver
3	SGM37603	3	24	8	<1.5	1.2	Common Anode	0.66	PWM & I ² C	WLCSP-1.78×1.36-12B,TDFN-3×3-12L	11-Bit, 3 Feedback Channels, 24V Input, Serial LED Driver
3	SGM37603A	3	24	8	<1.5	1.2	Common Anode	0.66	PWM & I ² C	WLCSP-1.78×1.36-12B,TDFN-3×3-12L	12-Bit, 3 Feedback Channels, 24V Input, Serial LED Driver
4	SGM3132	2.5	5	1	<5		Common Anode	0.55	One-Wire	TQFN-3×3-16L,TDFN-2×2-8L,MSOP-8	4P Ultra Low Dropout LED Driver
4	SGM3741B	3	18	10	<1	0.6	Common Anode	0.24	PWM & PWM	TQFN-3×3-16L	4 Feedback Channels, 18V Input, Serial LED Driver
4	SGM37604A	3	24	8	<1.5	1.2	Common Anode	0.66	PWM & I ² C	WLCSP-1.78×1.36-12B,TDFN-3×3-12L	12-Bit, 4 Feedback Channels, 24V Input, Serial LED Driver
6	SGM3138	2.7	5.5	1	<1	1	Common Anode	0.21	One-Wire	TQFN-3×3-16L	6P Charge Pump LED Driver
8	SGM3145	2.7	5.5	1	<2.5 @ V _{IN} = 4.2V	0.93	Common Anode	0.155	PWM	TQFN-3×3-20L	8P Charge Pump LED Driver

Isolated Power

Drivers per Package	Part Number	Output Power (W)	V _{CC} Range (V)	External Resistance (kΩ)	Input Frequency (kHz)	Logic Low Input Voltage (V)	Logic High Input Voltage (V)	I _{CC} Typ (mA)	Package	Features
1 [†]	SGM46000	3	2.5 ~ 5.5	5 ~ 390	200 ~ 2000	0.3	2	0.6	SOIC-8 (Exposed Pad),TDFN-2×3-8BL	3W Output Power, Programmable Oscillator Frequency Isolated Power Supply

Motor Drivers

Full Bridges per Package	2 [†]	1 [†]	V _{CC} Min (V)	V _{CC} Max (V)	RMS Output Current (A)	Peak Output Current (A)	Control Interface	R _{DS(ON)} (HS+LS) per Channel (mΩ)	Operating Temperature Range (°C)	Package	Features
	Part Number	Motor Type									
1	SGM42507	Brushed DC Motor	1.9	7.5	1.5		PH/EN	555	-40 to +125	SC70-6,TSOT-23-6	1.5A, 7.5V H-Bridge Driver for Motor/Coil
1	SGM42609	Brushed DC Motor	2.7	24	1.5	2	PWM	480	-40 to +125	MSOP-10,TDFN-3×3-10L	Single H-Bridge Motor Driver
2	SGM42600	Brushed DC/Stepper Motor	2.7	24	1.5	2	PWM	410	-40 to +125	TSSOP-16 (Exposed Pad),TQFN-4×4-16L	Dual H-Bridge Motor Driver
2	SGM42633	Brushed DC/Stepper Motor	2.5	12	0.6	1	PWM	1610	-40 to +125	TQFN-3×3-16L	Dual H-Bridge Motor Driver
2	SGM42622	Stepper Motor	1.8	10	1.3	2	STP/DIR	500	-40 to +85	TQFN-3×3-16L	Stepper Motor Driver with 1/256 Micro-Stepping
2	SGM42630	Stepper Motor	8	35	1.8	2.6	STP/DIR	290	-40 to +85	TSSOP-28 (Exposed Pad)	Stepper Motor Driver with 1/8 Micro-Stepping and Auto Decay Mode

Gate Drivers

Drivers per Package	1 [†]	Output Peak Current (A)	V _{CC} (V)	Rise Time (ns)	Fall Time (ns)	Logic Low Input Voltage (V)	Logic High Input Voltage (V)	Input Hysteresis (V)	I _{CC} Typ (mA)	Package	Features
	Part Number										
1	SGM48005	9/12	3 ~ 15	2.9	3.6	1.2	2.4		1	TSSOP-14	Zero Overshoot, Large Swing SIC & IGBT Driver with Precision Dual Power Rail Generation Circuit
1	SGM48010	8	4.5 ~ 20	10	10	0.9	2.5	0.2	0.13	TDFN-2×2-6L	Single-Channel High Speed Low-side Gate Driver
1	SGM48013	8	4.5 ~ 20	7	8	0.7	2.5	0.2	0.09	SOT-23-5	Single-Channel High Speed Low-side Gate Driver
1	SGM48017	8	4.5 ~ 20	7	8	0.7	2.5	0.2	0.09	SOT-23-5	Single-Channel High Speed Low-side Gate Driver
1	SGM48019	8	4.5 ~ 20	7	8	0.7	2.5	0.2	0.09	SOT-23-5	Single-Channel High Speed Low-side Gate Driver
2	SGM48524A	5	4.5 ~ 18	8	7	1.2 [†]	2 [†]	0.3	0.035	SOIC-8,TDFN-3×3-8L,MSOP-8 (Exposed Pad)	Dual-Channel High Speed Low-side Gate Driver
2	SGM48526	5	4.5 ~ 18	8	8	1.2 [†]	2 [†]	0.3	0.035	TDFN-3×3-8L	Dual-Channel High Speed Low-side Gate Driver

Note: † Typical Values @ 25°C